



Design Example Report

Title	<i>Generic PCB for DVD Player using TinySwitch-II</i>
Specification	Input: 90 – 265 VAC Output: 5V/1.5A, 3.3V/1.5A, 12V/0.5A, -12V/15mA
Application	DVD Player
Author	Power Integrations Applications Department
Document Number	DER-9
Date	February 4, 2004
Revision	1.0

Summary and Features

- Multiple Output PCB using TinySwitch-II
- Suitable for multiple output DVD supplies
- Suitable for many different output configurations
- Uses 14-pin EEL25 core
- Low EMI even with output grounded
- 3 tested circuits shown: TNY264, TNY266, and TNY267
- Low cost
- no common-mode choke, no Y-cap, no X-cap
- good output cross-regulation even with no TL431
- ~ 200 mW input power during standby using low-cost “DC Switch”

The products and applications illustrated herein (including circuits external to the products and transformer construction) may be covered by one or more U.S. and foreign patents or potentially by pending U.S. and foreign patent applications assigned to Power Integrations. A complete list of Power Integrations' patents may be found at www.powerint.com.

Table Of Contents

1	Introduction.....	3
2	Generic Power Supply PCB Layout.....	4
3	Schematic.....	5
4	Circuit Description	6
4.1	Input EMI Filtering	6
4.2	Primary Clamp Snubber	6
4.3	Output filtering.....	6
4.4	Output Feedback.....	6
4.5	“DC Switch”	6
4.6	+8V Option	6
4.7	-22V option	6
4.8	Floating +3V and Its Bias Option.....	7
4.9	-12V Linear Regulator Option.....	7
5	Bill Of Materials – Generic PSU with all options	8
6	Example One - 5.7W TNY264 DVD PSU	9
6.1	DVD Power Requirements	9
6.2	Schematic	10
6.3	Bill Of Materials	11
6.4	Transformer Electrical Diagram.....	12
	The Original 5.7W design in ASM-140292 used an EE19 core. Error! Bookmark not defined.	
6.5	Cross Regulation.....	12
6.6	Design Option with EEL25 - Spreadsheet.....	12
7	Example Two - 8.5W TNY266 DVD PSU	15
7.1	Specification.....	15
7.2	Schematic	16
7.3	Bill of Materials.....	17
7.4	Transformer Electrical Diagram.....	18
7.5	Cross Regulation.....	18
8	Example Three – 11.6W TNY267 DVD PSU	19
8.1	Specification.....	19
8.2	Schematic	20
8.3	Bill of Materials.....	21
8.4	Transformer Electrical Diagram.....	22
8.5	Cross Regulation.....	23
9	Revision History	24

Important Notes:

Although this board is designed to satisfy safety isolation requirements, the engineering prototype has not been agency approved. Therefore, all testing should be performed using an isolation transformer to provide the AC input to the prototype board.



Design Reports contain a power supply design specification, schematic, bill of materials, and transformer documentation. Performance data and typical operation characteristics are included. Typically only a single prototype has been built.



1 Introduction

This document is an engineering report describing a generic multiple output power supply PCB layout utilizing TinySwitch-II for a wide range of application of DVD players.

This design is low cost and meets EMI with no common-mode choke, no X-cap, and no Y-cap. This is possible with TinySwitch-II because of its built-in frequency jitter.

Cross-regulation is tight in spite of having a simple low-cost Zener regulation scheme. This is possible with TinySwitch-II because of its unique feedback scheme.

A low-cost non-Safety rated “DC Switch” allows shutdown with ~200 mW consumption at 230 Vac. This is possible with TinySwitch-II because of its *EcoSmart* features.

This document contains the power supply specification, schematic, bill of materials, transformer documentation, printed circuit layout, and performance data.



2 Generic Power Supply PCB Layout

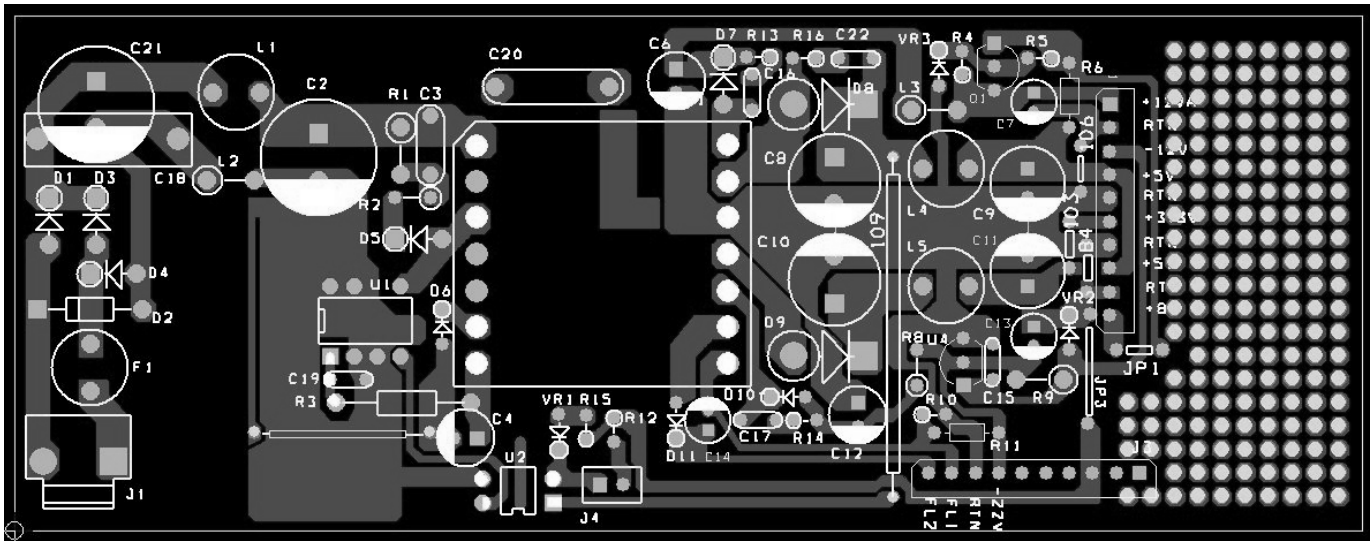
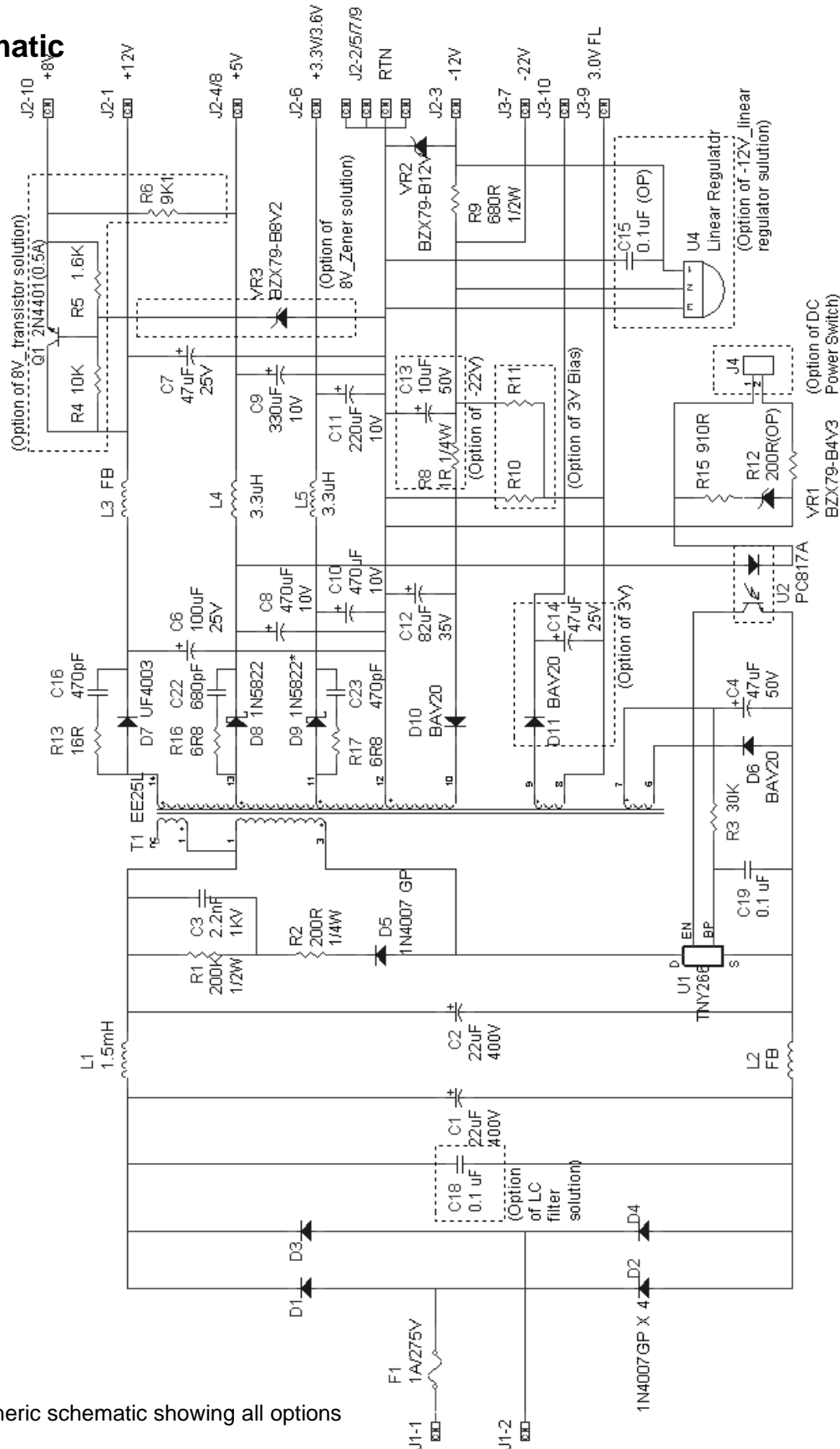

Figure 1 – Printed Circuit Board

Note: C17 and R14 are not stuffed, C23 and R17 are connected in series and attached to D9 (pin1 and pin2) on the bottom side



3 Schematic



Note: * D9 would be SB360 if the O/P is 3.6V

Figure 2 – Generic schematic showing all options

4 Circuit Description

4.1 Input EMI Filtering

C1 and C2 are the bulk capacitors. Together with L1 and L2, they form the EMI filter. TinySwitch-II's built-in frequency jitter helps achieve low EMI in spite of this very simple EMI filter.

C18 is an option for a high voltage ceramic capacitor in case a single electrolytic capacitor is required for the bulk capacitor.

4.2 Primary Clamp Snubber

D5, R1, R2, and C3 form the primary clamp snubber to clamp the voltage spike at the Drain pin after TinySwitch-II turn-off. D5 is a 1N4007G, a glass-passivated version of the standard 1N4007, with controlled reverse recovery. Its use, along with R2, improves EMI and efficiency.

4.3 Output filtering

C6, C8, C10, C12 and C14 are the main output capacitors. C7, C9, C11 and C13, along with L3, L4, L5 and R8, form second-stage output filters.

4.4 Output Feedback

U2, VR1, and R15 form the voltage feedback network. The 5V output voltage setpoint is set by the voltage drops of U2, VR1, and R15. The TinySwitch-II unique feedback scheme, with constant feedback current over line and load changes, means that the current in the zener does not change, thus the voltage drops in U2, VR1, and R15 do not change. This yields tight regulation in spite of the circuit's simplicity and low cost.

4.5 "DC Switch"

J4 is connected to a switch, wherein if it is closed, the 5V output drops to about 1.2V, because the zener ZR1 is essentially shorted out. All the outputs drop to about 1/5th of their normal voltages. During this condition, the load draws very little current. Because of TinySwitch-II's EcoSmart operation, it draws very little input power - <200 mW. This "DC Switch" can be used in place of a normal "AC Switch" that's used to disconnect the AC power. The DC Switch is lower cost because it does not have to be Safety-rated, and is lower voltage.

4.6 +8V Option

Q1, R4, R5 and R6 form a linear regulator to generate +8V in case of +8V is required. VR3 is another solution of generating +8V. Yet another option is to use a zener as a series pass element.

4.7 -22V option

R8 and C13 form a post-stage filter for -22V.



4.8 Floating +3V and Its Bias Option

D11 and C14 rectify and filter the AC voltage to generate a floating +3V. R10 and R11 are the option if the floating voltage needs a reference voltage. The level of the reference voltage can be adjusted by assigning different resistance value to R10 and R11.

4.9 -12V Linear Regulator Option

-12V is regulated through the coupling between -22V and 5V windings. Because its load usually is quite light, which is about tens of milliamps, the regulation should be enough for most applications. The option of a linear regulator U4 is provided if the tight regulation is preferred for the -12V.



5 Bill Of Materials – Generic PSU with all options

Item	Qty	Reference	Description	P/N	Manufacturer
1	1	C1*	22 μ F, 400 V	KMG400VB22RM	Nippon Chemi-Con
2	1	C2*	22 μ F, 400 V	KMG400VB22RM	Nippon Chemi-Con
3	1	C3	2.2 nF, 1 kV, ceramic Z5U dielectric		Any
4	1	C18	0.1 μ F, 630V, polyester		Any
5	2	C15, C19	0.1 μ F, 100 V, ceramic Z5U dielectric		Any
6	2	C16, C23	470 pF, 100 V, ceramic Z5U dielectric		Any
7	1	C22	680 pF, 100 V, ceramic Z5U dielectric		Any
8	1	C12	82 μ F, 35 V	KMG35VB82RM	Nippon Chemi-Con
9	1	C6	100 μ F, 25 V, low esr	KZE25VB101M	Nippon Chemi-Con
10	2	C8, C10	470 μ F, 10 V, low esr	KZE10VB471M	Nippon Chemi-Con
11	1	C9	330 μ F, 10 V, low esr	KZE10VB331M	Nippon Chemi-Con
12	1	C11	220 μ F, 10 V, low esr	KZE10VB221M	Nippon Chemi-Con
13	1	C4	47 μ F, 50 V, low esr	KZE50VB47RM	Nippon Chemi-Con
14	2	C7, C14	47 μ F, 25 V, low esr	KZE25VB47RM	Nippon Chemi-Con
15	1	C13	10 μ F, 50 V, low esr	KZE50VB10RM	Nippon Chemi-Con
16	4	D1, D2, D3, D4	1 A, 1000 V, Glass Passivated	1N4007GP	Any
17	1	D5	1 A, 1000 V, Glass Passivated	1N4007GP	Vishay / Any
18	3	D6, D10, D11	BAV20		Any
19	1	D7	UF4003, 200V		Any
20	2	D8, D9*	IN5822		Any
21	1	Q1	2N4401, Transistor, 0.5A, 40V		Any
22	1	F1	1A/275V Fuse		Any
23	1	L1	1.5 mH, 0.25 A		Any
24	2	L2, L3	Ferrite Bead		Any
25	2	L4, L5	3.3 μ H, 1 A		Any
26	1	R1	200 K Ω , 1/2 W, 5%		Any
27	2	R2, R12	200 Ω , 1/4 W, 5%		Any
28	1	R3	30 k Ω , 1/4 W, 5%		Any
29	1	R4	10 k Ω , 1/4 W, 5%		Any
30	1	R5	1.6 k Ω , 1/4 W, 5%		Any
31	1	R6	9.1 k Ω , 1/4 W, 5%		Any
32	1	R8	1 Ω , 1/4 W, 5%		Any
33	1	R9	680 Ω , 1/2 W, 5%		Any
34	1	R10	Customer Option		Any
35	1	R11	Customer Option		Any
36	1	R13	16 Ω , 1/4 W, 5%		Any
37	1	R15	910 Ω , 1/4 W, 5%		Any
38	2	R16, R17	6.8 Ω , 1/4 W, 5%		Any
39	1	VR1	4.3 V, 1/4 W, 2%	BZX79-B4V3	Any
40	1	VR2	12 V, 1/4 W, 2%	BZX79-B12V	Any
41	1	VR3	8.2 V, 1/4 W, 2%	BZX79-B8V2	Any
42	1	T1	EEL25	Custom	Any
43	1	U1	<i>TinySwitch-II</i>	TNY266P	Power Integrations
44	1	U2	Opto-coupler	PC817A	Isocom / Any
45	1	U4	Linear Regulator	LM13121Z-12, TO-92	National Semi
46	1	J4	DC Switch	Custom	Any
47	1	J1	AC Input Connector	Custom	Any
48	2	J2, J3	DC Output Connector	Custom	Any
49	1	PCB			

Note: C1 and C2 could be changed to smaller capacitance according to actual output power, D9 should be changed to SB360 if the O/P is 3.6V.



6 Example One - 5.7W TNY264 DVD PSU

A 5.7 W multiple output power supply was designed and successfully used to operate an Apex AD-1110 DVD player which was bought from a store. Performance using TNY264P exceeded the original power supply.

The original design used a different, full-custom PCB. However, it could be implemented using this generic PCB.

6.1 DVD Power Requirements

Description	Symbol	Min	Typ	Max	Units	Comment
Input						
Voltage	V_{IN}	90		265	VAC	2 Wire – no P.E.
Frequency	f_{LINE}	47	50/60	64	Hz	
Output						
Output Voltage 1	V_{OUT1}		3.3		V	20 MHz Bandwidth
Output Ripple Voltage 1	$V_{RIPPLE1}$				mV	
Output Current 1	I_{OUT1}		0.44	0.5	A	
Output Voltage 2	V_{OUT2}		5.0		V	± 5% 20 MHz Bandwidth
Output Ripple Voltage 2	$V_{RIPPLE2}$				mV	
Output Current 2	I_{OUT2}		0.54	0.74	A	
Output Voltage 3	V_{OUT3}		12		V	20 MHz Bandwidth
Output Ripple Voltage 3	$V_{RIPPLE3}$				mV	
Output Current 3	I_{OUT3}		0.017		A	
Output Voltage 4	V_{OUT4}		-12		V	20 MHz Bandwidth
Output Ripple Voltage 4	$V_{RIPPLE4}$				mV	
Output Current 4	I_{OUT4}		0.004		A	
Total Output Power						
Continuous Output Power	P_{OUT}		4.4		W	
Peak Output Power	P_{OUT_PEAK}			5.7	W	
Efficiency	η	66			%	Measured at full load, 25 °C
Environmental						
Conducted EMI		Meets CISPR22B / EN55022B				
Ambient Temperature	T_{AMB}	0		40	°C	Free convection, sea level

Note: Actual max current capability of PSU prototype is much higher than DVD player requirements



6.2 Schematic

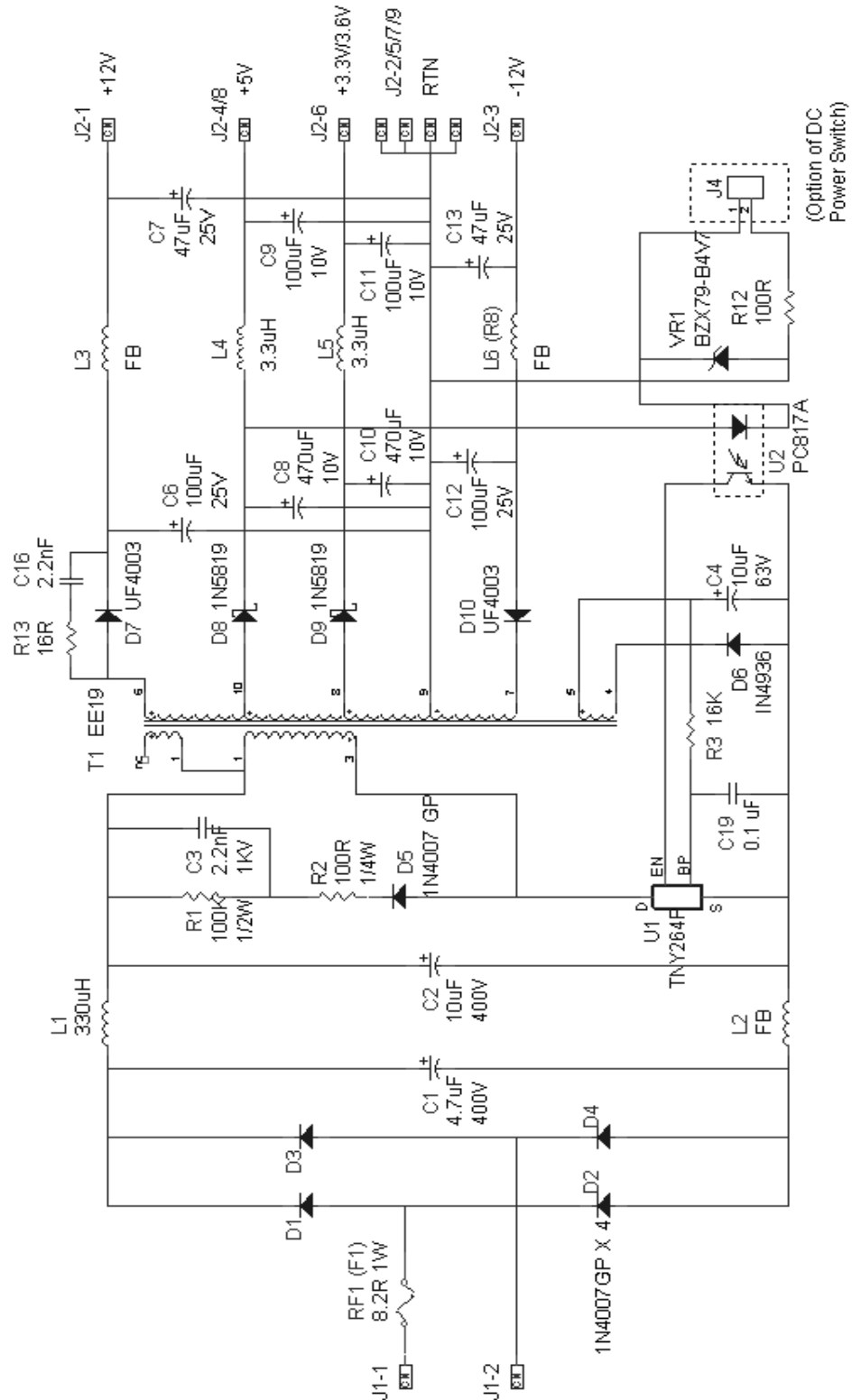

Figure 3 – Schematic.



6.3 Bill Of Materials

Item	Qty	Reference	Description	P/N	Manufacturer
1	1	C1	4.7 μ F, 400 V	KMG400VB4R7M	Nippon Chemi-Con
2	1	C2	10 μ F, 400 V	KMG400VB10RM	Nippon Chemi-Con
3	1	C3	2.2 nF, 1 kV, ceramic Z5U dielectric		Any
4	1	C19	0.1 μ F, 100 V, ceramic Z5U dielectric		Any
5	1	C4	10 μ F, 63 V	KMG63VB10RM	Nippon Chemi-Con
6	2	C6, C12	100 μ F, 25 V, low esr	KZE25VB101M	Nippon Chemi-Con
7	2	C8, C10	470 μ F, 10 V, low esr	KZE10VB471M	Nippon Chemi-Con
8	2	C7, C13	47 μ F, 25 V, low esr	KZE25VB47RM	Nippon Chemi-Con
9	2	C11, C9	100 μ F, 10 V, low esr	KZE10VB101M	Nippon Chemi-Con
10	1	C16	2.2 nF, 100 V ceramic		Any
11	4	D1, D2, D3, D4	1 A, 1000 V	1N4007	Any
12	1	D5	1 A, 1000 V, Glass Passivated	1N4007GP	Vishay / Any
13	1	D6	IN4936, 400V		Any
14	2	D7, D10	UF4003, 200V		Any
15	2	D8, D9	IN5819, 40V		Any
16	1	RF1	8.2 Ω , 1 W, Fusible Resistor		Any
17	1	L1	330 μ H, 0.2 A		Any
18	3	L2, L3, L6	Ferrite Bead		Any
19	2	L4, L5	3.3 μ H, 1 A		Any
20	1	R1	100 k Ω , 1/2 W, 5%		Any
21	2	R2, R12	100 Ω , 1/4 W, 5%		Any
22	1	R3	16 k Ω , 1/4 W, 5%		Any
23	1	R13	16 Ω , 1/4 W, 5%		Any
24	1	VR1	4.7V, 1/4 W, 2%	BZX79-B4V7	Any
25	1	T1	EE19	Custom	Any
26	1	U1	<i>TinySwitch-II</i>	TNY264P	Power Integrations
27	1	U2	Opto-coupler	PC817A	Isocom / Any
28	1	J4	DC Switch	Custom	Any
29	1	J1	AC Input Connector	Custom	Any
30	1	J2	DC output connector	Custom	Any
31	1	PCB			



6.4 Transformer Electrical Diagram

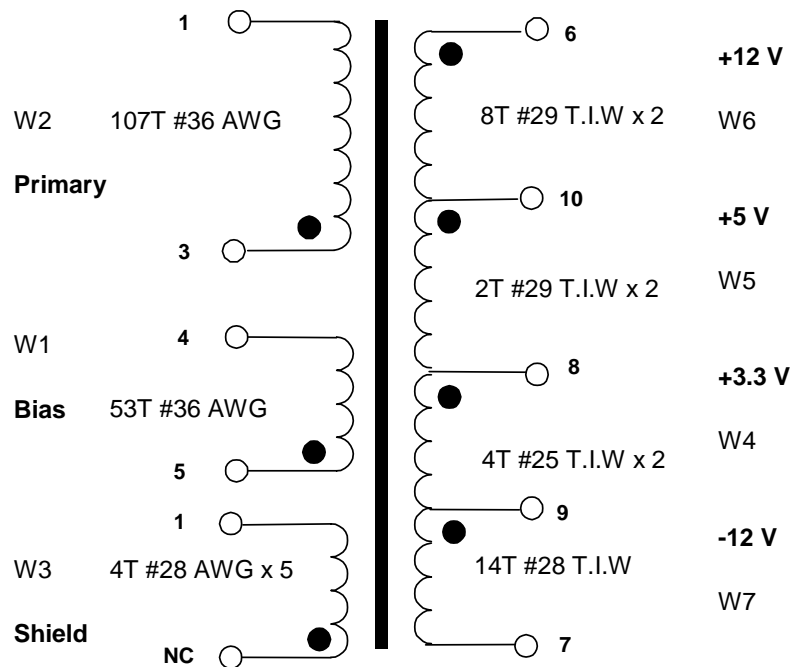

Figure 4 –Transformer Electrical Diagram

6.5 Cross Regulation

The extremes of voltages were measured in the actual DVD player, while going through start/stop/pause/load/eject cycles.

Output	Minimum	Maximum	Tolerance
3.3 V	3.28 V	3.35 V	+/- 1.06%
5 V	5.20 V	5.12 V	+/- 0.79%
+12 V	12.56V	12.92V	+/- 1.01%
-12 V	-13.32V	-12.92 V	+/- 1.52%

6.6 Design Option with EEL25 - Spreadsheet

The power supply was designed using an EE19 core. It is a smaller and lower cost core than the EEL25 that this generic PCB layout uses. However, an EEL25 can also be used for the design.

The design spreadsheet for an EEL25 is provided below. The turns ratio, Vor, Krp and output power remain the same. Note that the EMI windings have to be re-tuned since the core has changed.

ACDC_TNY-II_Rev1_1_032701 Copyright Power Integrations Inc. 2001		INPUT	INFO	OUTPUT	UNIT	ACDC_TNYII_Rev1_1_032701.xls: TinySwitch-II Continuous/Discontinuous Flyback Transformer Design Spreadsheet
ENTER APPLICATION VARIABLES						Customer
VACMIN	90			Volts		Minimum AC Input Voltage
VACMAX	265			Volts		Maximum AC Input Voltage
fL	50			Hertz		AC Mains Frequency
VO	5.1			Volts		Output Voltage
PO	5.7			Watts		Output Power
n	0.67					Efficiency Estimate
Z	0.6					Loss Allocation Factor
tC	3			mSeconds		Bridge Rectifier Conduction Time Estimate
CIN	14.7			uFarads		Input Filter Capacitor
ENTER TinySwitch-II VARIABLES						
TNY-II	TNY264			Universal		115 Doubled/230V
Chosen Device		TNY264	Power Out	6W		9W
ILIMITMIN			0.233	Amps		TINYSwitch Minimum Current Limit
ILIMITMAX			0.267	Amps		TINYSwitch Maximum Current Limit
fS			132000	Hertz		TINYSwitch Switching Frequency
fSmin			120000	Hertz		TINYSwitch Minimum Switching Frequency (inc. jitter)
fSmax			144000	Hertz		TINYSwitch Maximum Switching Frequency (inc. jitter)
VOR	98			Volts		Reflected Output Voltage
VDS	21			Volts		TINYSwitch on-state Drain to Source Voltage
VD	0.4			Volts		Output Winding Diode Forward Voltage Drop
KP			0.62			Ripple to Peak Current Ratio (0.6<KRP<1.0 : 1.0<KDP<6.0)
ENTER TRANSFORMER CORE/CONSTRUCTION VARIABLES						
Core Type	EEL25					
Core		EEL25		P/N:		PC40EE25.4/32/6.4-Z
Bobbin		EEL25_BOBBIN		P/N:		*
AE			0.404	cm^2		Core Effective Cross Sectional Area
LE			7.34	cm		Core Effective Path Length
AL			1420	nH/T^2		Ungapped Core Effective Inductance
BW			22.3	mm		Bobbin Physical Winding Width
M	0			mm		Safety Margin Width (Half the Primary to Secondary Creepage Distance)
L	2					Number of Primary Layers
NS	6					Number of Secondary Turns
DC INPUT VOLTAGE PARAMETERS						
VMIN			90	Volts		Minimum DC Input Voltage
VMAX			375	Volts		Maximum DC Input Voltage
CURRENT WAVEFORM SHAPE PARAMETERS						
DMAX			0.59			Maximum Duty Cycle
I AVG			0.09	Amps		Average Primary Current
IP			0.23	Amps		Minimum Peak Primary Current
IR			0.14	Amps		Primary Ripple Current
IRMS			0.13	Amps		Primary RMS Current
TRANSFORMER PRIMARY DESIGN PARAMETERS						
LP			2656	uHenries		Primary Inductance
NP			107			Primary Winding Number of Turns
ALG			232	nH/T^2		Gapped Core Effective Inductance
BM			1642	Gauss		Flux Density, IP (BP<3000)
BAC			442	Gauss		AC Flux Density for Core Loss Curves (0.5 X Peak to Peak)
ur			2053			Relative Permeability of Ungapped Core
LG			0.18	mm		Gap Length (Lg > 0.1 mm)
BWE			44.6	mm		Effective Bobbin Width



OD			0.42	mm	Maximum Primary Wire Diameter including insulation
INS			0.06	mm	Estimated Total Insulation Thickness (= 2 * film thickness)
DIA			0.36	mm	Bare conductor diameter
AWG			28	AWG	Primary Wire Gauge (Rounded to next smaller standard AWG value)
CM			161	Cmils	Bare conductor effective area in circular mils
CMA		Comment	1265	Cmils/Amp	CAN DECREASE CMA < 500 (decrease L(primary layers),increase NS,smaller Core)
TRANSFORMER SECONDARY DESIGN PARAMETERS (SINGLE OUTPUT / SINGLE OUTPUT EQUIVALENT)					
Lumped parameters					
ISP			4.15	Amps	Peak Secondary Current
ISRMS			1.91	Amps	Secondary RMS Current
IO			1.12	Amps	Power Supply Output Current
IRIPPLE			1.54	Amps	Output Capacitor RMS Ripple Current
CMS			381	Cmils	Secondary Bare Conductor minimum circular mils
AWGS			24	AWG	Secondary Wire Gauge (Rounded up to next larger standard AWG value)
DIAS			0.51	mm	Secondary Minimum Bare Conductor Diameter
ODS			3.72	mm	Secondary Maximum Outside Diameter for Triple Insulated Wire
INSS			1.60	mm	Maximum Secondary Insulation Wall Thickness
VOLTAGE STRESS PARAMETERS					
VDRAIN			601	Volts	Maximum Drain Voltage Estimate (Includes Effect of Leakage Inductance)
PIVS			26	Volts	Output Rectifier Maximum Peak Inverse Voltage
TRANSFORMER SECONDARY DESIGN PARAMETERS (MULTIPLE OUTPUTS)					
1st output					
VO1	3.3			Volts	Output Voltage
IO1	0.440			Amps	Output DC Current
PO1			1.45	Watts	Output Power
VD1	0.4			Volts	Output Diode Forward Voltage Drop
NS1			4.04		Output Winding Number of Turns
ISRMS1			0.750	Amps	Output Winding RMS Current
IRIPPLE1			0.61	Amps	Output Capacitor RMS Ripple Current
PIVS1			17	Volts	Output Rectifier Maximum Peak Inverse Voltage
CMS1			150	Cmils	Output Winding Bare Conductor minimum circular mils
AWGS1			28	AWG	Wire Gauge (Rounded up to next larger standard AWG value)
DIAS1			0.32	mm	Minimum Bare Conductor Diameter
ODS1			5.52	mm	Maximum Outside Diameter for Triple Insulated Wire
2nd output					
VO2	12.0			Volts	Output Voltage
IO2	0.020			Amps	Output DC Current
PO2			0.24	Watts	Output Power
VD2	0.8			Volts	Output Diode Forward Voltage Drop
NS2			13.96		Output Winding Number of Turns
ISRMS2			0.034	Amps	Output Winding RMS Current
IRIPPLE2			0.03	Amps	Output Capacitor RMS Ripple Current
PIVS2			61	Volts	Output Rectifier Maximum Peak Inverse Voltage
CMS2			7	Cmils	Output Winding Bare Conductor minimum circular mils
AWGS2			41	AWG	Wire Gauge (Rounded up to next larger standard AWG value)
DIAS2			0.07	mm	Minimum Bare Conductor Diameter
ODS2			1.60	mm	Maximum Outside Diameter for Triple Insulated Wire



7 Example Two - 8.5W TNY266 DVD PSU

Using a TNY266 in place of TNY264 of Example 1 can provide 2.8W more power. It was tested in an Apex AD-1225 DVD player, which was bought from a store. The new design's performance using TNY266P exceeded the original power supply's.

The original design used a different, full-custom PCB. However, it could be implemented using this generic PCB.

7.1 Specification

Description	Symbol	Min	Typ	Max	Units	Comment
Input						
Voltage	V_{IN}	90		265	VAC	2 Wire – no P.E.
Frequency	f_{LINE}	47	50/60	64	Hz	
No-load Input Power (230 VAC)				0.3	W	
Output						
Output Voltage 1	V_{OUT1}		3.6		V	20 MHz Bandwidth
Output Ripple Voltage 1	$V_{RIPPLE1}$			50	mV	
Output Current 1	I_{OUT1}		1	1.5	A	
Output Voltage 2	V_{OUT2}		5.0		V	± 5% 20 MHz Bandwidth
Output Ripple Voltage 2	$V_{RIPPLE2}$			50	mV	
Output Current 2	I_{OUT2}		1	1.5	A	
Output Voltage 3	V_{OUT3}		12		V	20 MHz Bandwidth
Output Ripple Voltage 3	$V_{RIPPLE3}$			100	mV	
Output Current 3	I_{OUT3}		0.2	0.5	A	
Output Voltage 4	V_{OUT4}		-12		V	zener regulated 20 MHz Bandwidth
Output Ripple Voltage 4	$V_{RIPPLE4}$			100	mV	
Output Current 4	I_{OUT4}		0.012	0.013	A	
Total Output Power						
Continuous Output Power	P_{OUT}		4.9		W	
Peak Output Power	P_{OUT_PEAK}			8.5	W	
Efficiency	η		71		%	Measured at full load, 25 °C
Environmental						
Conducted EMI						Meets CISPR22B / EN55022B
Ambient Temperature	T_{AMB}	0		40	°C	Free convection, sea level

* Actual Apex AD-1225 DVD player max current requirements are much lower than PSU capability



7.2 Schematic

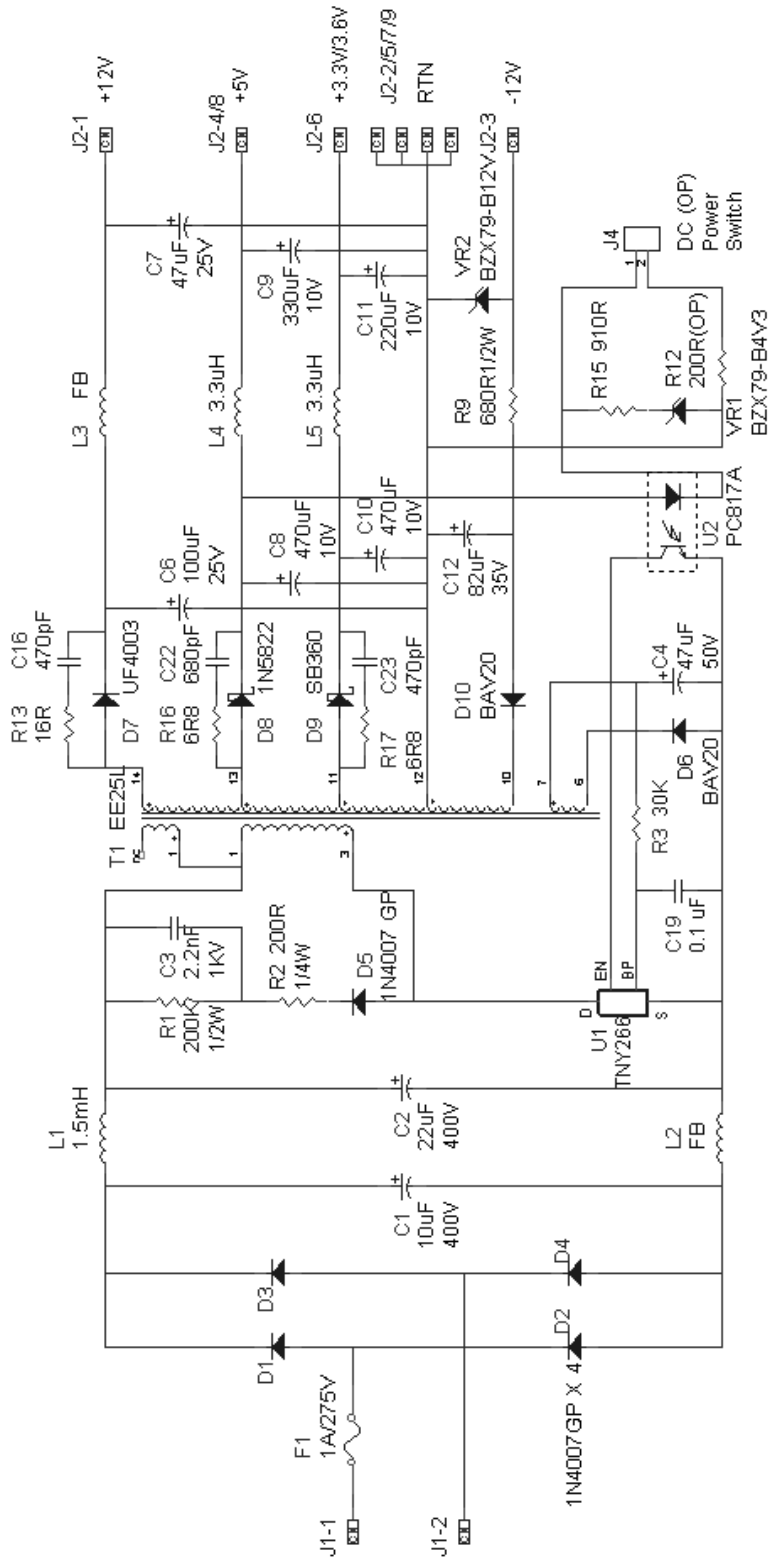

Figure 5 – Schematic.



7.3 Bill of Materials

Item	Qty	Reference	Description	P/N	Manufacturer
1	1	C1	10 μ F, 400 V	KMG400VB10RM	Nippon Chemi-Con
2	1	C2	22 μ F, 400 V	KMG400VB22RM	Nippon Chemi-Con
3	1	C3	2.2 nF, 1 kV, ceramic Z5U dielectric		Any
4	1	C19	0.1 μ F, 100 V, ceramic Z5U dielectric		Any
5	1	C12	82 μ F, 35 V	KMG35VB82RM	Nippon Chemi-Con
6	1	C6	100 μ F, 25 V, low esr	KZE25VB101M	Nippon Chemi-Con
7	2	C8, C10	470 μ F, 10 V, low esr	KZE10VB471M	Nippon Chemi-Con
8	1	C9	330 μ F, 10 V, low esr	KZE10VB331M	Nippon Chemi-Con
9	1	C11	220 μ F, 10 V, low esr	KZE10VB221M	Nippon Chemi-Con
10	1	C4	47 μ F, 50 V, low esr	KZE50VB47RM	Nippon Chemi-Con
11	1	C7	47 μ F, 25 V, low esr	KZE25VB47RM	Nippon Chemi-Con
12	1	C16, C23	470pF, 100 V, ceramic Z5U dielectric		Any
13	1	C22	680pF, 100 V, ceramic Z5U dielectric		Any
14	4	D1, D2, D3, D4	1 A, 1000 V, Glass Passivated	1N4007GP	Any
15	1	D5	1 A, 1000 V, Glass Passivated	1N4007GP	Vishay / Any
16	2	D6, D10	BAV20		Any
17	1	D7	UF4003, 200V		Any
18	1	D8	IN5822		Any
19	1	D9	SB360		Any
20	1	F1	1A/275V Fuse		Any
21	1	L1	1.5 mH, 0.25 A		Any
22	2	L2, L3	Ferrite Bead		Any
23	2	L4, L5	3.3 μ H, 1 A		Any
24	1	R1	200 K Ω , 1/2 W, 5%		Any
25	2	R2, R12	200 Ω , 1/4 W, 5%		Any
26	1	R3	30 k Ω , 1/4 W, 5%		Any
27	1	R9	680 Ω , 1/2 W, 5%		Any
28	1	R13	16 Ω , 1/4 W, 5%		Any
29	1	R16, R17	6.8 Ω , 1/4 W, 5%		Any
30	1	R15	910 Ω , 1/4 W, 5%		Any
31	1	VR1	4.3 V, 1/4 W, 2%	BZX79-B4V3	Any
32	1	VR2	12 V, 1/4 W, 2%	BZX79-B12V	Any
33	1	T1	EEL25	Custom	Any
34	1	U1	<i>TinySwitch-II</i>	TNY266P	Power Integrations
35	1	U2	Opto-coupler	PC817A	Isocom / Any
36	1	J4	DC Switch	Custom	Any
37	1	J1	AC Input Connector	Custom	Any
38	1	J2	DC Output Connector	Custom	Any
39	1	PCB			



7.4 Transformer Electrical Diagram

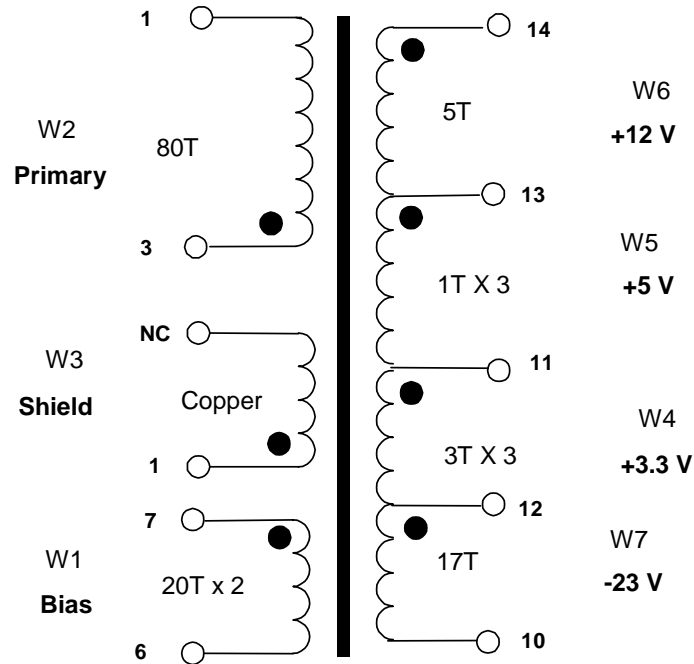

Figure 6 –Transformer Electrical Diagram

7.5 Cross Regulation

The extremes of voltages were measured in the actual DVD player, while going through start/stop/pause/load/eject cycles.

Output	Minimum	Maximum	Tolerance
3.6 V	3.644	3.848	+6.89 / +1.22%
5 V	4.96	5.04	+0.80 / -0.80%
+12 V	11.68	12.56	+4.67 / -2.67%
-12 V	-12.48	-12.40	+4.00 / -3.33%



8 Example Three – 11.6W TNY267 DVD PSU

This 9W (11.6W peak) power supply will meet most low end DVD players' power requirements. This design was tested in a DVD player. The performance using TNY267P exceeded the original power supply.

The original design used a different, full-custom PCB. However, it could be implemented using this generic PCB.

8.1 Specification

Description	Symbol	Min	Typ	Max	Units	Comment
Input						
Voltage	V_{IN}	85		265	VAC	2 Wire – no P.E.
Frequency	f_{LINE}	47	50/60	64	Hz	
No-load Input Power (230 VAC)				0.3	W	
Output						
Output Voltage 1	V_{OUT1}		3.3		V	20 MHz Bandwidth
Output Ripple Voltage 1	$V_{RIPPLE1}$			33	mV	
Output Current 1	I_{OUT1}		0.5	1.5	A	
Output Voltage 2	V_{OUT2}		5.0		V	± 5%
Output Ripple Voltage 2	$V_{RIPPLE2}$			50	mV	20 MHz Bandwidth
Output Current 2	I_{OUT2}		0.75	1.5	A	
Output Voltage 3	V_{OUT3}		12		V	20 MHz Bandwidth
Output Ripple Voltage 3	$V_{RIPPLE3}$			60	mV	
Output Current 3	I_{OUT3}		0.1	0.5	A	
Output Voltage 4	V_{OUT4}		-12		V	zener regulated
Output Ripple Voltage 4	$V_{RIPPLE4}$			60	mV	20 MHz Bandwidth
Output Current 4	I_{OUT4}		0.01		A	
Output Voltage 5	V_{OUT5}		-23		V	20 MHz Bandwidth
Output Ripple Voltage 5	$V_{RIPPLE5}$			400	mV	
Output Current 5	I_{OUT5}		0.01	.08	A	
Output Voltage 6	V_{OUT6}		3.0		V	floating output for display
Output Ripple Voltage 6	$V_{RIPPLE6}$			200	mV	20 MHz Bandwidth
Output Current 6	I_{OUT6}		0.1		A	
Total Output Power						
Continuous Output Power	P_{OUT}		9.0		W	
Peak Output Power	P_{OUT_PEAK}			11.6	W	
Efficiency	η		72		%	Measured at full load, 25 °C
Environmental						
Conducted EMI						Meets CISPR22B / EN55022B
Ambient Temperature	T_{AMB}	0		40	°C	Free convection, sea level

* Actual DVD player max current requirements are much lower than PSU capability



8.2 Schematic

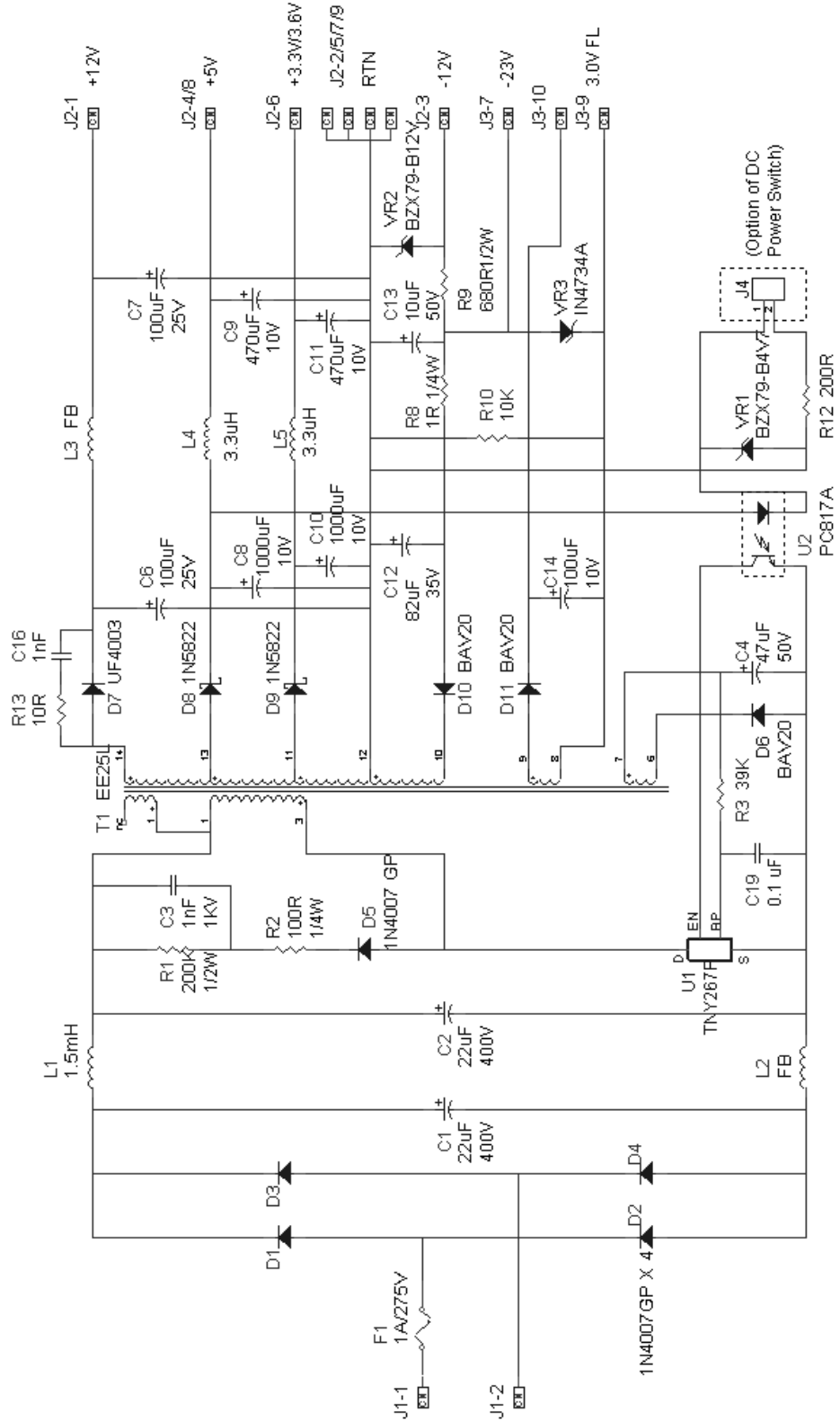

Note: VR3 is placed on the bottom side of PCB

Figure 7 – Schematic.



8.3 Bill of Materials

Item	Qty	Reference	Description	P/N	Manufacturer
1	2	C1, C2	20 μ F, 400 V	KMG400VB20RM	Nippon Chemi-Con
2	1	C3	1 nF, 1 kV, ceramic Z5U dielectric		Any
3	1	C19	0.1 μ F, 100 V, ceramic Z5U dielectric		Any
4	1	C12	82 μ F, 35 V	KMG35VB82RM	Nippon Chemi-Con
5	2	C6, C7	100 μ F, 25 V, low esr	KZE25VB101M	Nippon Chemi-Con
6	2	C8, C10	1000 μ F, 10 V, low esr	KZE10VB102M	Nippon Chemi-Con
7	2	C9, C11	470 μ F, 10 V, low esr	KZE10VB331M	Nippon Chemi-Con
8	1	C14	100 μ F, 10 V, low esr	KZE10VB101M	Nippon Chemi-Con
9	1	C4	47 μ F, 50 V, low esr	KZE50VB47RM	Nippon Chemi-Con
10	1	C13	10 μ F, 50 V	KMG50VB10RM	Nippon Chemi-Con
11	1	C16	1 nF, 100 V, ceramic Z5U dielectric		Any
12	4	D1, D2, D3, D4	1 A, 1000 V, Glass Passivated	1N4007GP	Any
13	1	D5	1 A, 1000 V, Glass Passivated	1N4007GP	Vishay / Any
14	3	D6, D10, D11	BAV20		Any
15	1	D7	UF4003, 200V		Any
16	2	D8, D9	IN5822		Any
17	1	F1	1A/275V Fuse		Any
18	1	L1	1.5 mH, 0.25 A		Any
19	2	L2, L3	Ferrite Bead		Any
20	2	L4, L5	3.3 μ H, 1 A		Any
21	1	R1	200 K Ω , 1/2 W, 5%		Any
22	1	R2	100 Ω , 1/4 W, 5%		Any
23	1	R12	200 Ω , 1/4 W, 5%		Any
24	1	R3	39 k Ω , 1/4 W, 5%		Any
25	1	R9	680 Ω , 1/2 W, 5%		Any
26	1	R13	10 Ω , 1/4 W, 5%		Any
27	1	R8	1 Ω , 1/4 W, 5%		Any
28	1	R10	10 K Ω , 1/4 W, 5%		Any
29	1	VR1	4.7 V, 1/4 W, 2%	BZX79-B4V7	Any
30	1	VR2	12 V, 1/4 W, 2%	BZX79-B12V	Any
31	1	VR3	5.6 V, 1/2 W, 5%	1N4742	Any
32	1	T1	EEL25	Custom	Any
33	1	U1	<i>TinySwitch-II</i>	TNY267P	Power Integrations
34	1	U2	Opto-coupler	PC817A	Isocom / Any
35	1	J4	DC Switch	Custom	Any
36	1	J1	AC Input Connector	Custom	Any
37	2	J2, J3	DC Output Connector	Custom	Any
38	1	PCB			



8.4 Transformer Electrical Diagram

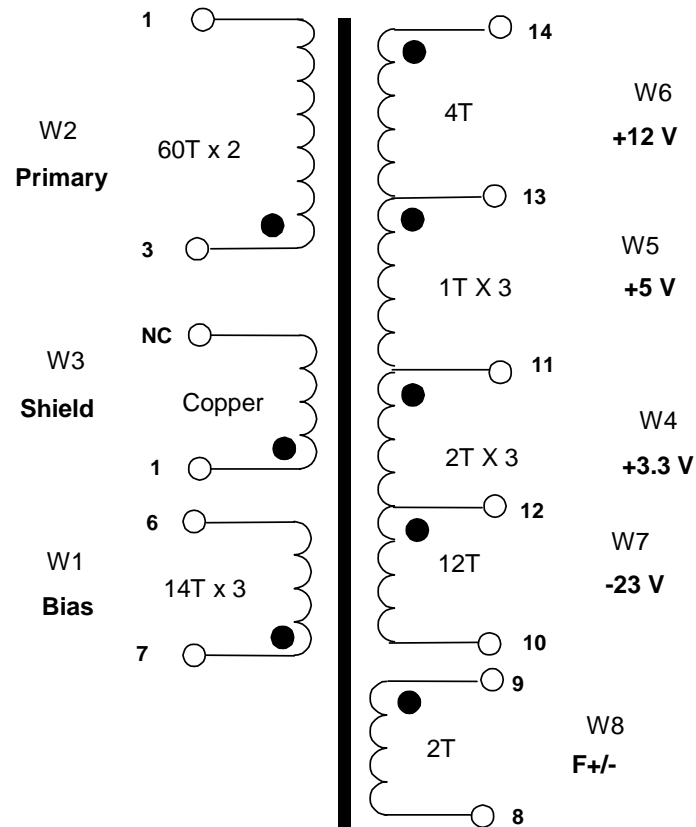

Figure 8 –Transformer Electrical Diagram

8.5 Cross Regulation

The extremes of voltages were measured in the actual DVD player, while going through start/stop/pause/load/eject cycles.

Output	Minimum	Maximum
3.3 V	3.288 V	3.468 V
5 V	5.08 V	5.24 V
+12 V	12.28 V	13.4V
-12 V	-11.68 V	-11.76 V
-23 V	-21.88 V	-24.08 V
F- / F+	2.24 V	2.744 V



9 Revision History

Date	Author	Revision	Description & changes	Reviewed
February 4, 2004	DZ/JC	1.0	Initial Release	AM/VC



For the latest updates, visit our Web site: www.powerint.com

Power Integrations reserves the right to make changes to its products at any time to improve reliability or manufacturability. Power Integrations does not assume any liability arising from the use of any device or circuit described herein, nor does it convey any license under its patent rights or the rights of others.

The products and applications illustrated herein (including circuits external to the products and transformer construction) may be covered by one or more U.S. and foreign patents or potentially by pending U.S. and foreign patent applications assigned to Power Integrations. A complete list of Power Integrations' patents may be found at www.powerint.com.

The PI Logo, **TOPSwitch**, **TinySwitch**, **LinkSwitch**, and **EcoSmart** are registered trademarks of Power Integrations, Inc. **PI Expert** and **DPA-Switch** are trademarks of Power Integrations, Inc.
© Copyright 2003, Power Integrations, Inc.

WORLD HEADQUARTERS

NORTH AMERICA - WEST

Power Integrations
5245 Hellyer Avenue
San Jose, CA 95138 USA.
Main: +1-408-414-9200
Customer Service:
Phone: +1-408-414-9665
Fax: +1-408-414-9765
e-mail:
usasales@powerint.com

CHINA

Power Integrations
International Holdings, Inc.
Rm# 1705, Bao Hua Bldg.
1016 Hua Qiang Bei Lu
Shenzhen Guangdong,
518031
Phone: +86-755-8367-5143
Fax: +86-755-8377-9610
e-mail:
chinasales@powerint.com

APPLICATIONS HOTLINE

World Wide +1-408-414-9660

EUROPE & AFRICA

Power Integrations (Europe) Ltd.
Centennial Court
Easthampstead Road
Bracknell
Berkshire RG12 1YQ,
United Kingdom
Phone: +44-1344-462-300
Fax: +44-1344-311-732
e-mail: eurosales@powerint.com

KOREA

Power Integrations
International Holdings, Inc.
Rm# 402, Handuk Building,
649-4 Yeoksam-Dong,
Kangnam-Gu,
Seoul, Korea
Phone: +82-2-568-7520
Fax: +82-2-568-7474
e-mail: koreasales@powerint.com

APPLICATIONS FAX

World Wide +1-408-414-9760

SINGAPORE

Power Integrations, Singapore
51 Goldhill Plaza #16-05
Republic of Singapore,
308900
Phone: +65-6358-2160
Fax: +65-6358-2015
e-mail:
singaporesales@powerint.com

JAPAN

Power Integrations, K.K.
Keihin-Tatemono 1st Bldg.
12-20 Shin-Yokohama
2-Chome,
Kohoku-ku, Yokohama-shi,
Kanagawa 222-0033, Japan
Phone: +81-45-471-1021
Fax: +81-45-471-3717
e-mail:
japansales@powerint.com

TAIWAN

Power Integrations
International Holdings, Inc.
17F-3, No. 510
Chung Hsiao E. Rd.,
Sec. 5,
Taipei, Taiwan 110, R.O.C.
Phone: +886-2-2727-1221
Fax: +886-2-2727-1223
e-mail:
taiwansales@powerint.com

INDIA (Technical Support)

Innovatech
#1, 8th Main Road
Vasanthnagar
Bangalore, India 560052
Phone: +91-80-226-6023
Fax: +91-80-228-9727
e-mail:
indiasales@powerint.com

