



Low Power Voltage Controlled Oscillator

The MC12148 requires an external parallel tank circuit consisting of the inductor (L) and capacitor (C). A varactor diode may be incorporated into the tank circuit to provide a voltage variable input for the oscillator (VCO). This device may also be used in many other applications requiring a fixed frequency clock.

The MC12148 is ideal in applications requiring a local oscillator. Systems include electronic test equipment and digital high-speed telecommunications.

The MC12148 is based on the VCO circuit topology of the MC1648. The MC12148 has been realized utilizing Motorola's MOSAIC III advanced bipolar process technology which results in a design which can operate at a much higher frequency than the MC1648 while utilizing half the current. Please consult with the MC1648 data sheet for additional background information.

The ECL output circuitry of the MC12148 is not a traditional open emitter output structure and instead has an on-chip termination resistor with a nominal value of 500 ohms. This facilitates direct ac-coupling of the output signal into a transmission line. Because of this output configuration, an external pull-down resistor is not required to provide the output with a dc current path. This output is intended to drive one ECL load. If the user needs to fanout the signal, an ECL buffer such as the MC10EL16 Line Receiver/Driver should be used.

NOTE: The MC12148 is NOT useable as a crystal oscillator.

- Typical Operating Frequency Up to 1100 MHz
- Low-Power 20 mA at 5.0 Vdc Power Supply
- 8-Pin SOIC Package
- Phase Noise -90 dBc/Hz at 25 kHz Typical

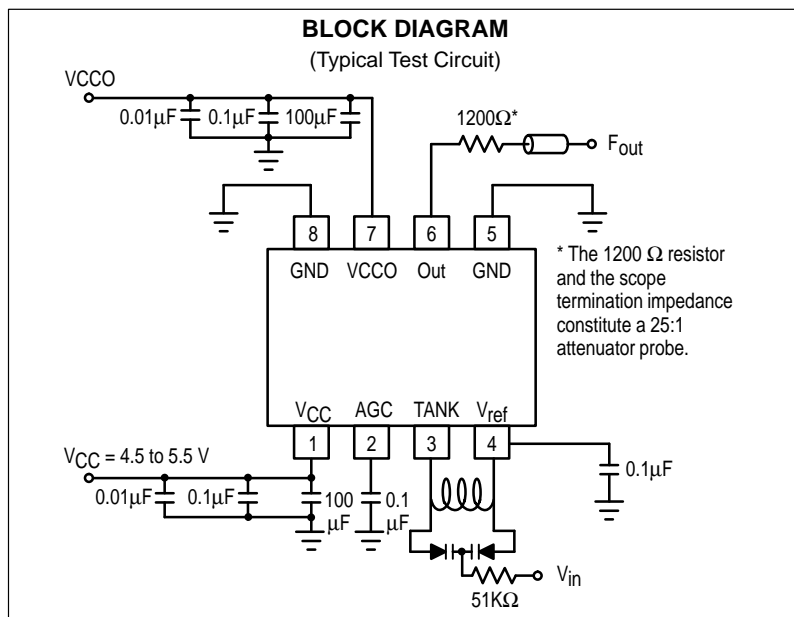

MC12148

LOW POWER VOLTAGE CONTROLLED OSCILLATOR

SEMICONDUCTOR TECHNICAL DATA



D SUFFIX
PLASTIC PACKAGE
CASE 751
(SO-8)

PIN CONNECTIONS

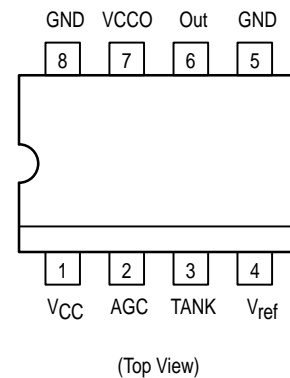

ORDERING INFORMATION

Device	Operating Temperature Range	Package
MC12148D	T _A = -40 to 85°C	SO-8

MC12148

MAXIMUM RATINGS

Parameter	Symbol	Value	Unit
Power Supply Voltage, Pins 1, 7	V_{CC}	-0.5 to 7.0	Vdc
Operating Temperature Range	T_A	-40 to 85	°C
Storage Temperature Range	T_{stg}	-65 to 150	°C

NOTE: ESD data available upon request.

ELECTRICAL CHARACTERISTICS ($V_{CC} = 5.0\text{ V}$; $T_A = -40\text{ to }85^\circ\text{C}$, unless otherwise noted.)

Characteristic	Symbol	Min	Typ	Max	Unit	
Supply Current	I_{CC}	-	19	25	mA	
Output Level HIGH (1.0 M Ω Impedance)	V_{OH}	3.95	4.17	4.61	V	
Output Level LOW (1.0 M Ω Impedance)	V_{OL}	3.04	3.41	3.60	V	
CSR @ 25 kHz Offset, 1.0 Hz BW	$\mathcal{L}(f)$	-	-90	-	dBc/Hz	
CSR @ 1.0 MHz Offset, 1.0 Hz BW	$\mathcal{L}(f)$	-	-120	-	dBc/Hz	
SNR (Signal to Noise Ratio from Carrier)	SNR	-	40	-	dB	
Frequency Stability	Supply Drift	Fsts	-	3.6	-	KHz/mV
	Thermal Drift	Fstt	-	0.1	-	KHz/°C
Second Harmonic (from Carrier)	H2	-	-25	-	dBc	

Figure 1. Circuit Schematic

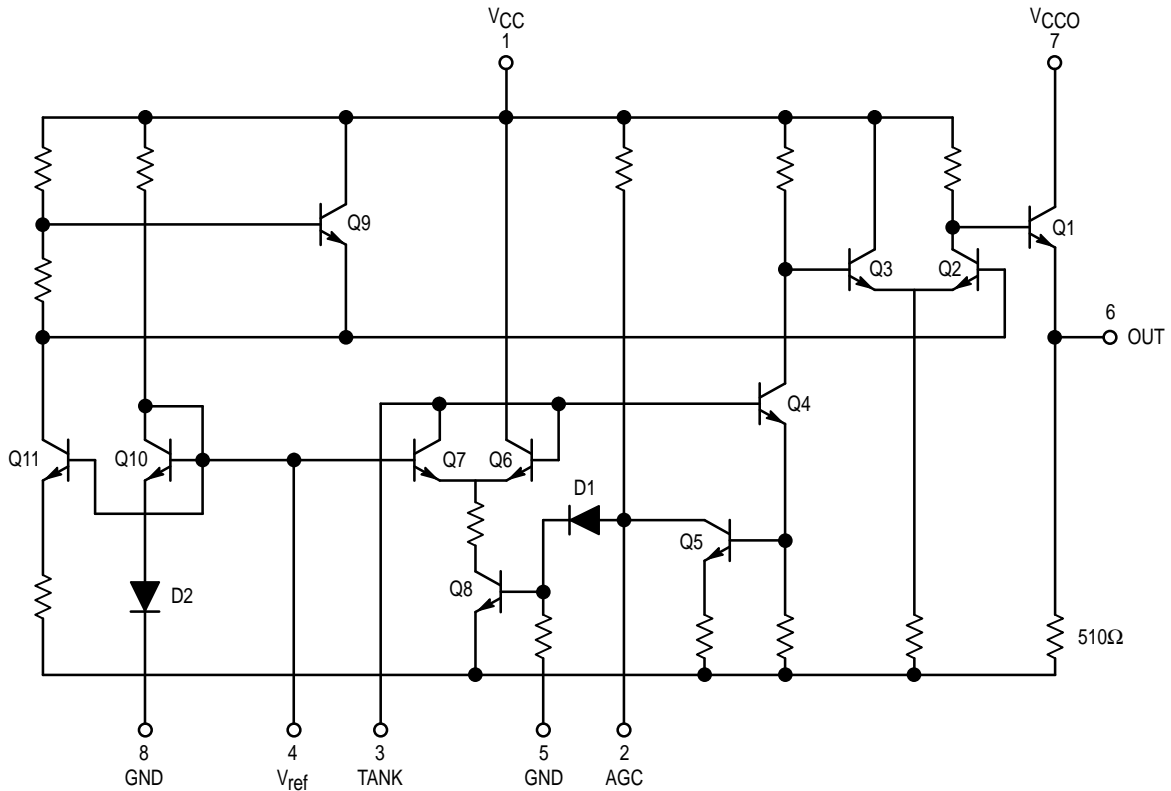

MC12148

Figure 2. Typical Evaluation Results
(CSR MC12148 5.0 Vdc; V_{CC} @ 25°C; 930 MHz CW)

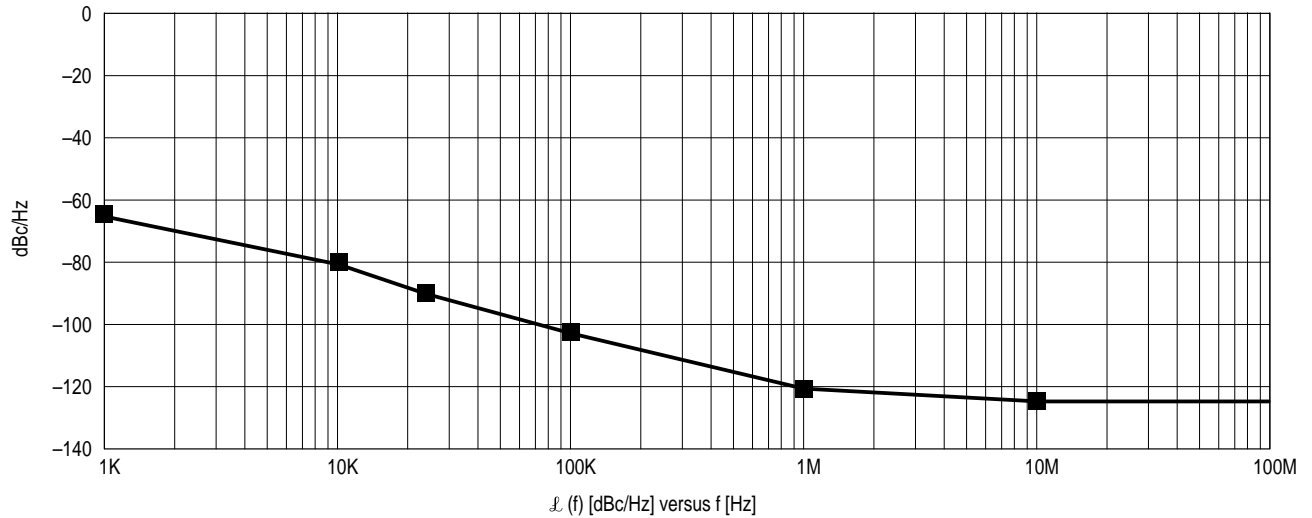

Tank Component Suppliers

Below are suppliers who manufacture tuning varactors and inductors which can be used to build an external tank circuit. Motorola has used these varactors and inductors for evaluation purposes, however, there are other vendors who manufacture similar products.

Coilcraft Inductors A01T thru A05T

Coilcraft—Coilcraft, Inc.
1102 Silver Lake Rd.
Gary, Illinois 60013
708-639-6400

Alpha Tuning Diodes DVH6730 Series

Alpha Semiconductor Devices Division
20 Sylvan Road
Woburn, MA 01801
617-935-5150

Loral Tuning Varactors GC1500 Series

Loral
16 Maple Road
Chelmsford, Massachusetts 01824
508-256-8101 or 508-256-4113

* At 1.1 GHz, use a Coilcraft A01T Springair coil at 2.5 nH and a Loral Varactor 3.0 to 8.0 pF at $V_{IN} = 1.0$ to 5.0 V.

MC12148

OUTLINE DIMENSIONS

D SUFFIX
PLASTIC PACKAGE
CASE 751-06
(SO-8)
ISSUE T

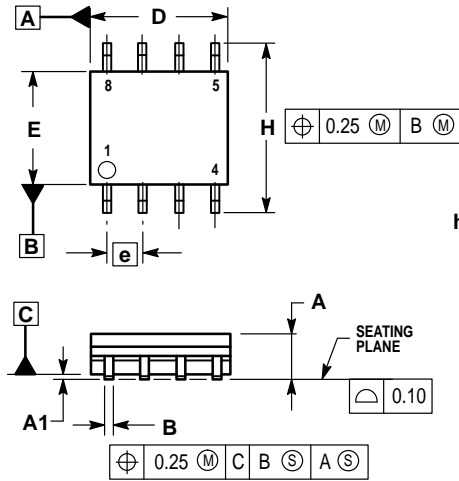

NOTES:

1. DIMENSIONING AND TOLERANCING PER ASME Y14.5M, 1994.
2. DIMENSIONS ARE IN MILLIMETER.
3. DIMENSION D AND E DO NOT INCLUDE MOLD PROTRUSION.
4. MAXIMUM MOLD PROTRUSION 0.15 PER SIDE.
5. DIMENSION B DOES NOT INCLUDE DAMBAR PROTRUSION. ALLOWABLE DAMBAR PROTRUSION SHALL BE 0.127 TOTAL IN EXCESS OF THE B DIMENSION AT MAXIMUM MATERIAL CONDITION.

MILLIMETERS		
DIM	MIN	MAX
A	1.35	1.75
A1	0.10	0.25
B	0.35	0.49
C	0.19	0.25
D	4.80	5.00
E	3.80	4.00
e	1.27 BSC	
H	5.80	6.20
h	0.25	0.50
L	0.40	1.25
θ	0°	7°

Motorola reserves the right to make changes without further notice to any products herein. Motorola makes no warranty, representation or guarantee regarding the suitability of its products for any particular purpose, nor does Motorola assume any liability arising out of the application or use of any product or circuit, and specifically disclaims any and all liability, including without limitation consequential or incidental damages. "Typical" parameters which may be provided in Motorola data sheets and/or specifications can and do vary in different applications and actual performance may vary over time. All operating parameters, including "Typicals" must be validated for each customer application by customer's technical experts. Motorola does not convey any license under its patent rights nor the rights of others. Motorola products are not designed, intended, or authorized for use as components in systems intended for surgical implant into the body, or other applications intended to support or sustain life, or for any other application in which the failure of the Motorola product could create a situation where personal injury or death may occur. Should Buyer purchase or use Motorola products for any such unintended or unauthorized application, Buyer shall indemnify and hold Motorola and its officers, employees, subsidiaries, affiliates, and distributors harmless against all claims, costs, damages, and expenses, and reasonable attorney fees arising out of, directly or indirectly, any claim of personal injury or death associated with such unintended or unauthorized use, even if such claim alleges that Motorola was negligent regarding the design or manufacture of the part. Motorola and  are registered trademarks of Motorola, Inc. Motorola, Inc. is an Equal Opportunity/Affirmative Action Employer.

Mfax is a trademark of Motorola, Inc.

How to reach us:

USA/EUROPE/Locations Not Listed: Motorola Literature Distribution;
 P.O. Box 5405, Denver, Colorado 80217. 1-303-675-2140 or 1-800-441-2447

JAPAN: Motorola Japan Ltd.; SPD, Strategic Planning Office, 141,
 4-32-1 Nishi-Gotanda, Shinagawa-ku, Tokyo, Japan. 81-3-5487-8488

Customer Focus Center: 1-800-521-6274

Mfax™: RMFAX0@email.sps.mot.com – TOUCHTONE 1-602-244-6609
 Motorola Fax Back System – US & Canada ONLY 1-800-774-1848
 – http://sps.motorola.com/mfax/

ASIA/PACIFIC: Motorola Semiconductors H.K. Ltd.; 8B Tai Ping Industrial Park,
 51 Ting Kok Road, Tai Po, N.T., Hong Kong. 852-26629298

HOME PAGE: <http://motorola.com/sps/>

