

IO – budiče MOS a IGBT

Technická specifikace:

- I_{OUT} výstupní proud budiče
- U_{OUT} výstupní napětí budiče
- U_{CC} napájecí napětí řídicí části budiče
- $U_{IN „1“}$ vstupní napětí budiče pro hodnotu logické jedničky
- $U_{IN „0“}$ vstupní napětí budiče pro hodnotu logické nuly
- T_A pracovní teplota okolí -40+125°C
- UV integrovaná ochrana při poklesu výstupního napětí („undervoltage“)
- MT „delay matching“
- DT „deadtime“
- PDT programovatelný „deadtime“
- SD vstup pro blokování obou výstupů (možno využít jako řízený „deadtime“)
- CL možnost detekce a omezení proudu řízeného výkonového obvodu
- CS možnost detekce a blokování proudu řízeného výkonového obvodu

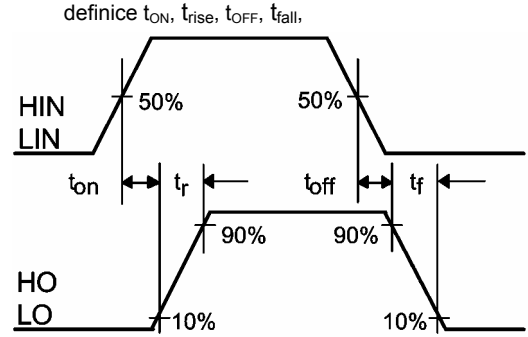

dolní spínače

označení	pouzdro	zapojení	I_{OUT} zdroj min [mA]	I_{OUT} zátěž min [mA]	U_{OUT} min [V]	U_{OUT} max [V]	U_{CC} min [V]	U_{CC} max [V]	$U_{IN „1“}$ min [V]	$U_{IN „0“}$ max [V]	t_{ON} typ [ns]	t_{rise} typ [ns]	t_{OFF} typ [ns]	t_{fall} typ [ns]	speciální funkce
IR2121	DIP-8	jednoduchý	1000	2000	12	18	-0.3	25	2.2	0.8	150	43	150	26	UV, CL
IR4426	DIP-8	dvojitý	1500	1500	6	20			2.7	0.8	85	15	65	10	
IR4426S	SOIC-8	dvojitý	1500	1500	6	20			2.7	0.8	85	15	65	10	
IR4427	DIP-8	dvojitý	1500	1500	6	20			2.7	0.8	85	15	65	10	
IR4427S	SOIC-8	dvojitý	1500	1500	6	20			2.7	0.8	85	15	65	10	
IR4428	DIP-8	dvojitý	1500	1500	6	20			2.7	0.8	85	15	65	10	
IR4428S	SOIC-8	dvojitý	1500	1500	6	20			2.7	0.8	85	15	65	10	

IR2121

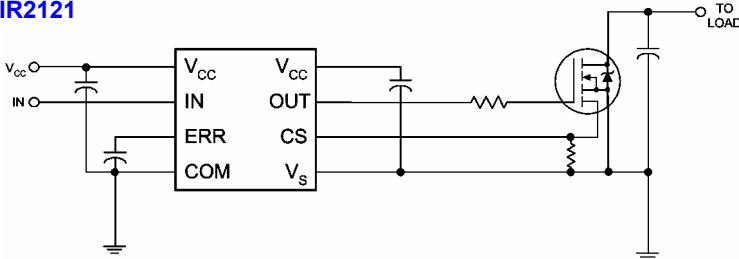

IR2121

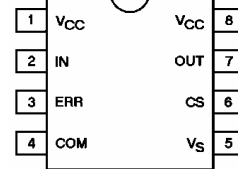

vnitřní blokové zapojení obvodu IR2121

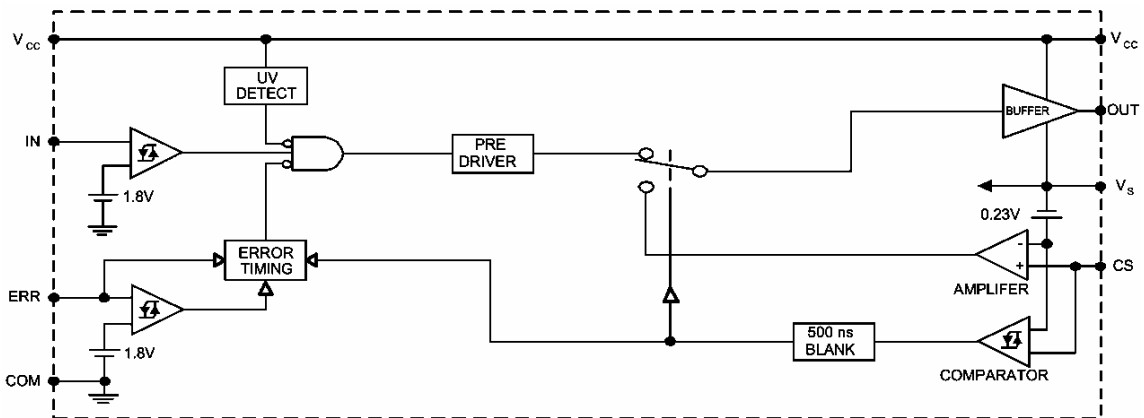

IR4426, IR4426S, IR4427, IR4427S, IR4428, IR4428S

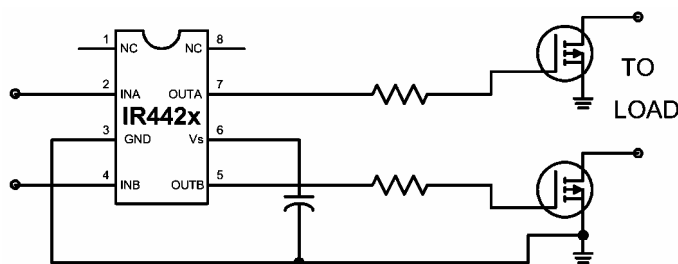

IR2126, IR4426S

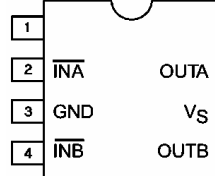

IR4427, IR4427S

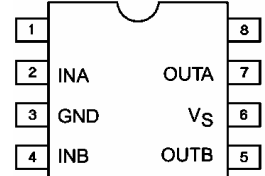

IR4428, IR4428S

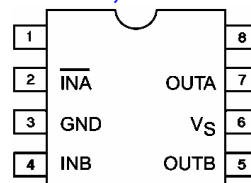

IO – budiče MOS a IGBT**samostatný horní spínač**

označení	pouzdro	V_{RRM} max [V]	I_{OUT} zdroj min [mA]	I_{OUT} zátěž min [mA]	U_{OUT} min [V]	U_{OUT} max [V]	U_{CC} min [V]	U_{CC} max [V]	U_{IN} "1" min [V]	U_{IN} "0" max [V]	t_{ON} typ [ns]	t_{RISE} typ [ns]	t_{OFF} typ [ns]	t_{FALL} typ [ns]	speciální funkce
IR2117	DIP-8	600	200	420	10	20	-0.3	25	9.5	6	125	80	105	40	UV
IR2117S	SOIC-8	600	200	420	10	20	-0.3	25	9.5	6	125	80	105	40	UV
IR2118	DIP-8	600	200	420	10	20	-0.3	25	9.5	6	125	80	105	40	UV
IR2118S	SOIC-8	600	200	420	10	20	-0.3	25	9.5	6	125	80	105	40	UV
IR2122	DIP-8	600	110	110	10	20	-0.3	25	3	0.8	250	250	200	250	UV, CS
IR2122S	SOIC-8	600	110	110	10	20	-0.3	25	3	0.8	250	250	200	250	UV, CS
IR2125	DIP-8	500	1000	2000	12	18	-0.3	25	2.2	0.8	150	43	150	26	UV, CL
IR2125S	SOIC-16w	500	1000	2000	12	18	-0.3	25	2.2	0.8	150	43	150	26	UV, CL
IR2127	DIP-8	600	200	420	12	20	-0.3	25	3	0.8	200	80	150	40	UV CS
IR2127S	SOIC-8	600	200	420	12	20	-0.3	25	3	0.8	200	80	150	40	UV CS
IR21271		600	200	420	9	20	-0.3	25	3	0.8	200	80	150	40	UV CS
IR21271S	SOIC-8	600	200	420	9	20	-0.3	25	3	0.8	200	80	150	40	UV CS
IR2128	DIP-8	600	200	420	12	20	-0.3	25	3	0.8	200	80	150	40	UV CS
IR2128S	SOIC-8	600	200	420	12	20	-0.3	25	3	0.8	200	80	150	40	UV CS

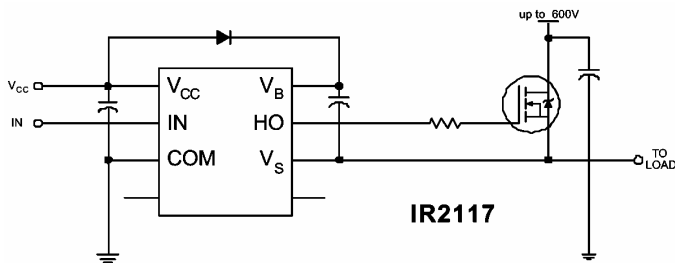
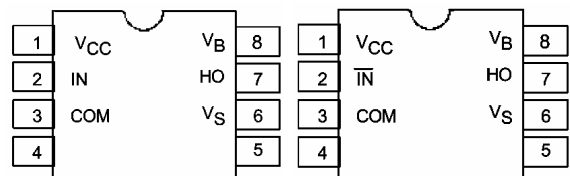
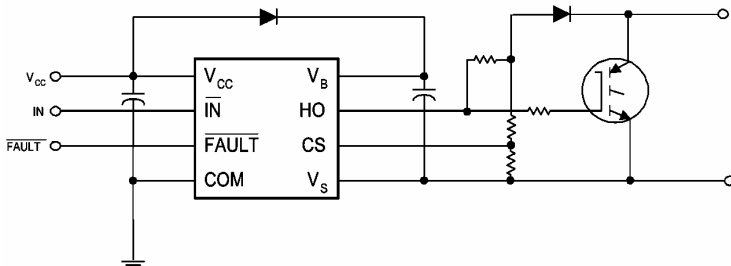
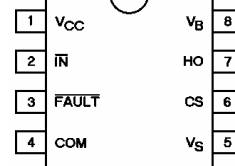
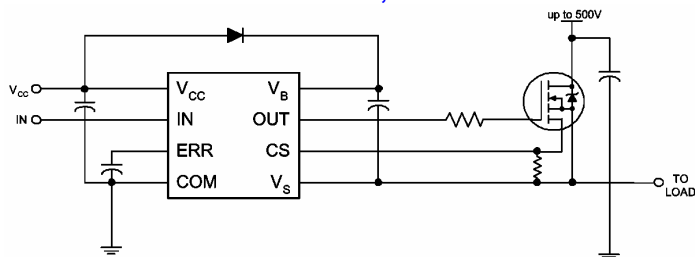
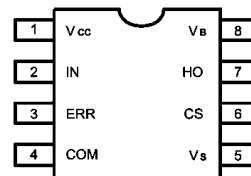
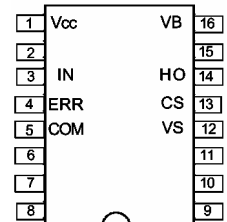
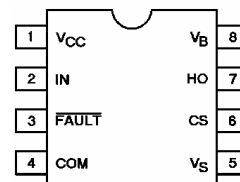
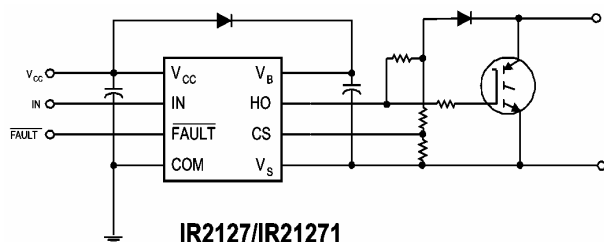
IR2117, IR2117S (IR2118, IR2118S negovaný vstup)**IR2117, IR2117S****IR2118, IR2118S****IR2122, IR2122S, IR2128, IR2128S****IR2122, IR2122S, IR2128, IR2128S****IR2125, IR2125S****IR2125****IR2125S****IR2127, IR2127S, IR21271, IR21271S**

IO – budiče MOS a IGBT**dvojice - dolní a horní spínače**

označení	pouzdro	V _{RRM} max [V]	I _{OUT} zdroj min [mA]	I _{OUT} zátěž min [mA]	U _{OUT} min [V]	U _{OUT} max [V]	U _{CC} min [V]	U _{CC} max [V]	U _{IN} "1" min [V]	U _{IN} "0" max [V]	t _{ON} typ [ns]	t _{rise} typ [ns]	t _{OFF} typ [ns]	t _{fall} typ [ns]	MT max [ns]	DT typ [ns]	speciální funkce
IR2101	DIP-8	600	130	270	10	20	-0.3	25	3	0.8	160	100	150	50	50		UV
IR2101S	SOIC-8	600	130	270	10	20	-0.3	25	3	0.8	160	100	150	50	50		UV
IR2102	DIP-8	600	130	270	10	20	-0.3	25	3	0.8	160	100	150	50	50		UV
IR2102S	SOIC-8	600	130	270	10	20	-0.3	25	3	0.8	160	100	150	50	50		UV
IR2103	DIP-8	600	130	270	10	20	-0.3	25	3	0.8	680	100	150	50	60	520	UV
IR2103S	SOIC-8	600	130	270	10	20	-0.3	25	3	0.8	680	100	150	50	60	520	UV
IR2106	DIP-8	600	120	250	10	20	-0.3	25	2.9	0.8	220	150	200	50	30		UV
IR2106S	SOIC-8	600	120	250	10	20	-0.3	25	2.9	0.8	220	150	200	50	30		UV
IR21064	DIP-14	600	120	250	10	20	-0.3	25	2.9	0.8	220	150	200	50	30		UV
IR21064S	SOIC-14	600	120	250	10	20	-0.3	25	2.9	0.8	220	150	200	50	30		UV
IR2108	DIP-8	600	120	250	10	20	-0.3	25	2.9	0.8	220	150	200	50	60	540	UV
IR2108S	SOIC-8	600	120	250	10	20	-0.3	25	2.9	0.8	220	150	200	50	60	540	UV
IR21084	DIP-14	600	120	250	10	20	-0.3	25	2.9	0.8	220	150	200	50	60	540	UV
IR21084S	SOIC-14	600	120	250	10	20	-0.3	25	2.9	0.8	220	150	200	50	60	540	UV
IR2110	DIP-14	500	2000	2000	10	20	-0.3	25	9.5	6	120	25	94	17	10		UV, SD
IR2110S	SOIC-16w	500	2000	2000	10	20	-0.3	25	9.5	6	120	25	94	17	10		UV, SD
IR2110-1	DIP14s-1	500	2000	2000	10	20	-0.3	25	9.5	6	120	25	94	17	10		UV, SD
IR2110-2	DIP16s-2	500	2000	2000	10	20	-0.3	25	9.5	6	120	25	94	17	10		UV, SD
IR2112	DIP-14	600	200	420	10	20	-0.3	25	9.5	6	125	80	105	40	30		UV, SD
IR2112S	SOIC-16w	600	200	420	10	20	-0.3	25	9.5	6	125	80	105	40	30		UV, SD
IR2112-1	DIP14s-1	600	200	420	10	20	-0.3	25	9.5	6	125	80	105	40	30		UV, SD
IR2112-2	DIP16s-2	600	200	420	10	20	-0.3	25	9.5	6	125	80	105	40	30		UV, SD
IR2113	DIP-14	600	2000	2000	10	20	-0.3	25	9.5	6	120	25	94	17	10		UV, SD
IR2113S	SOIC-16w	600	2000	2000	10	20	-0.3	25	9.5	6	120	25	94	17	10		UV, SD
IR2113-1	DIP14s-1	600	2000	2000	10	20	-0.3	25	9.5	6	120	25	94	17	10		UV, SD
IR2113-2	DIP16s-2	600	2000	2000	10	20	-0.3	25	9.5	6	120	25	94	17	10		UV, SD
IR2181	DIP-8	600	1400	1800	10	20	-0.3	25	2.7	0.8	180	40	220	20	35		UV
IR2181S	SOIC-8	600	1400	1800	10	20	-0.3	25	2.7	0.8	180	40	220	20	35		UV
IR21814	DIP-14	600	1400	1800	10	20	-0.3	25	2.7	0.8	180	40	220	20	35		UV
IR21814S	SOIC-14	600	1400	1800	10	20	-0.3	25	2.7	0.8	180	40	220	20	35		UV
IR2183	DIP-8	600	1400	1800	10	20	-0.3	25	2.7	0.8	180	40	220	20	50	400	UV, DT
IR2183S	SOIC-8	600	1400	1800	10	20	-0.3	25	2.7	0.8	180	40	220	20	50	400	UV, DT
IR21834	DIP-14	600	1400	1800	10	20	-0.3	25	2.7	0.8	180	40	220	20	50	400	UV, PDT
IR21834S	SOIC-14	600	1400	1800	10	20	-0.3	25	2.7	0.8	180	40	220	20	50	400	UV, PDT
IR2213	DIP-14	1200	1700	2000	10	20	-0.3	25	9.5	6	280	25	225	17	30		UV, SD
IR2213S	SOIC-16w	1200	1700	2000	10	20	-0.3	25	9.5	6	280	25	225	17	30		UV, SD

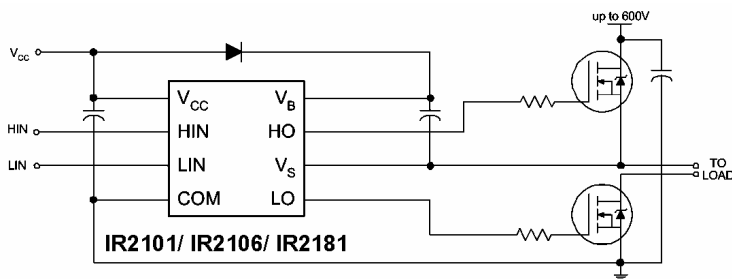
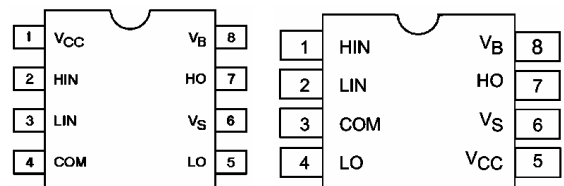
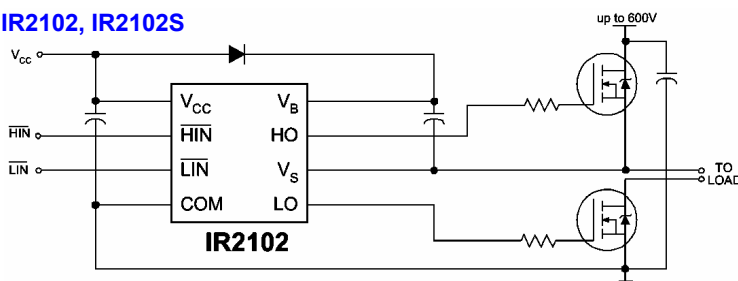
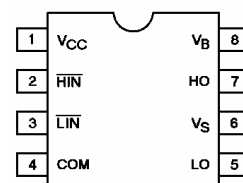
IR2101, IR2101S, IR2106, IR2106S, IR2181, IR2181S**IR2101, IR2101S,
IR2106, IR2106S****IR2181, IR2181S****IR2102, IR2102S****IR2102, IR2102S**

IO – budiče MOS a IGBT

dvojice - dolní a horní spínače

IR2103, IR2103S, IR2108, IR2108S, IR2183, IR2183S

**IR2103, IR2103S,
IR2108, IR2108S**

IR2183, IR2183S

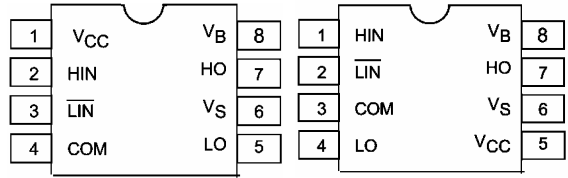
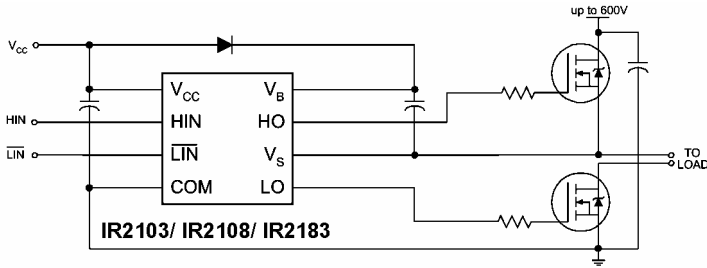

IR21064, IR21064S, IR21814, IR21814S

IR21064, IR21064S

IR21814, IR21814S

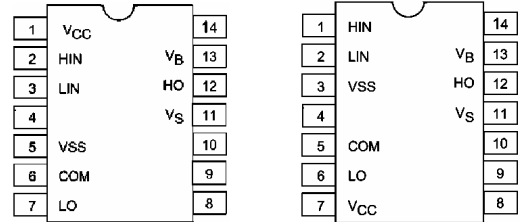
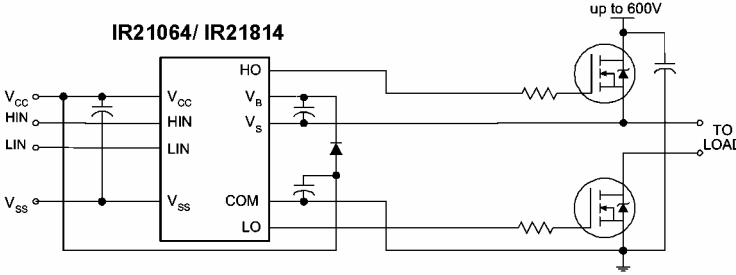

IR21084, IR21084S, IR21834, IR21834S

IR21084, IR21084S

IR21834, IR21834S

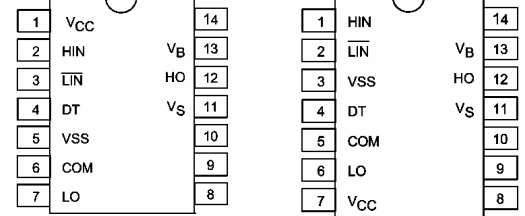
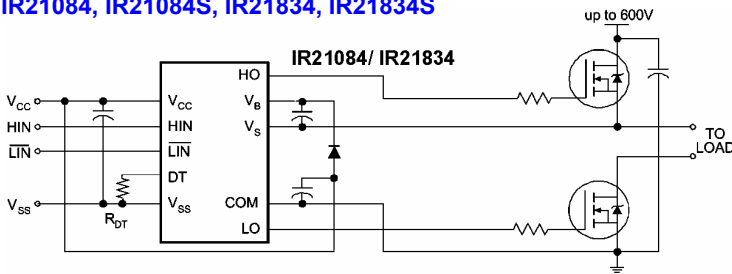

**IR2110, IR2110S, IR2112, IR2112S, IR2113, IR2113S
IR2213, IR2213S**

**IR2110, IR2110-1,
IR2112, IR2112-1
IR2113, IR2113-1
IR2213**

**IR2110S, IR2110-2
IR2112S, IR2112-2
IR2113S, IR2113-2
IR2213S**

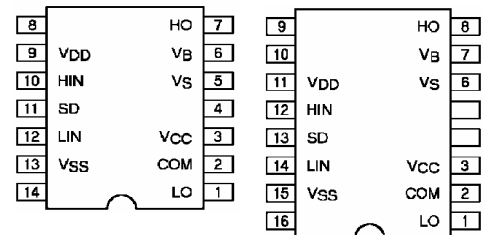
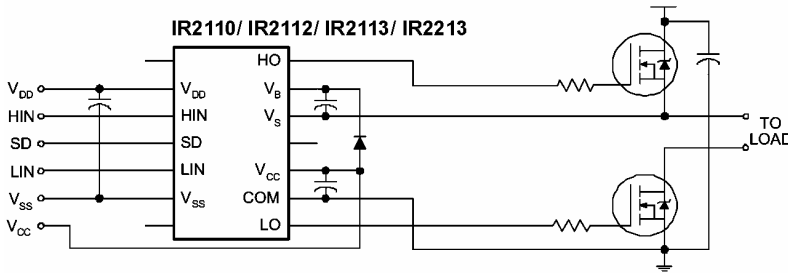

vnitřní blokové zapojení obvodu IR2110, IR2112, IR2113, IR2213

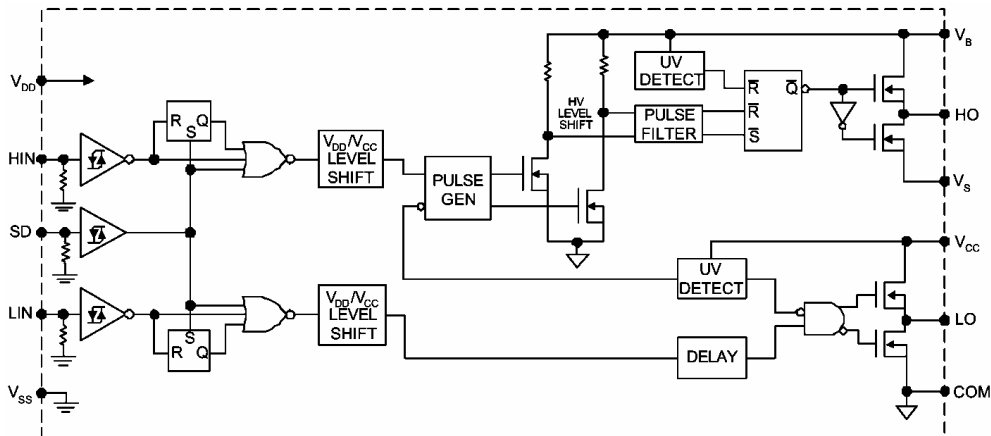

IO – budiče MOS a IGBT

dvojice - pŕlmŕstky

označení	pouzdro	V _{RRM} max [V]	I _{OUT} zdroj min [mA]	I _{OUT} zátěž min [mA]	U _{OUT} min [V]	U _{OUT} max [V]	U _{CC} min [V]	U _{CC} max [V]	U _{IN} "1" min [V]	U _{IN} "0" max [V]	t _{ON} typ [ns]	t _{rise} typ [ns]	t _{OFF} typ [ns]	t _{fall} typ [ns]	MT max [ns]	DT typ [ns]	speciální funkce
IR2104	DIP-8	600	130	270	10	20	-0.3	25	3	0.8	680	100	150	50	60	520	UV, SD, DT
IR2104S	SOIC-8	600	130	270	10	20	-0.3	25	3	0.8	680	100	150	50	60	520	UV, SD, DT
IR2105	DIP-8	600	130	270	10	20	-0.3	25	3	0.8	680	100	150	50	60	520	UV, DT
IR2105S	SOIC-8	600	130	270	10	20	-0.3	25	3	0.8	680	100	150	50	60	520	UV, DT
IR2109	DIP-8	600	120	250	10	20	-0.3	25	2.9	0.8	750	150	200	50	60	540	UV
IR2109S	SOIC-8	600	120	250	10	20	-0.3	25	2.9	0.8	750	150	200	50	60	540	UV
IR21091	DIP-8	600	120	250	10	20	-0.3	25	2.9	0.8	750	150	200	50	60	540	UV
IR21091S	SOIC-8	600	120	250	10	20	-0.3	25	2.9	0.8	750	150	200	50	60	540	UV
IR21094	DIP-14	600	120	250	10	20	-0.3	25	2.9	0.8	750	150	200	50	60	540	UV
IR21094S	SOIC-14	600	120	250	10	20	-0.3	25	2.9	0.8	750	150	200	50	60	540	UV
IR2111	DIP-8	600	200	420	10	20	-0.3	25	6.4/9.5/12.6	3.8/6/8.3	750	80	150	40	30	650	UV, DT
IR2111S	SOIC-8	600	200	420	10	20	-0.3	25	6.4/9.5/12.6	3.8/6/8.3	750	80	150	40	30	650	UV, DT
IR2184	DIP-8	600	1400	1800	10	20	-0.3	25	2.7	0.8	680	40	270	20	50	400	UV, DT, SD
IR2184S	SOIC-8	600	1400	1800	10	20	-0.3	25	2.7	0.8	680	40	270	20	50	400	UV, DT, SD
IR21844	DIP-14	600	1400	1800	10	20	-0.3	25	2.7	0.8	680	40	270	20	50	400	UV, PDT, SD
IR21844S	SOIC-14	600	1400	1800	10	20	-0.3	25	2.7	0.8	680	40	270	20	50	400	UV, PDT, SD

IR2105, IR2105S, IR2111, IR2111S

IR2105, IR2105S, IR2111, IR2111S

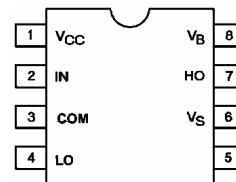
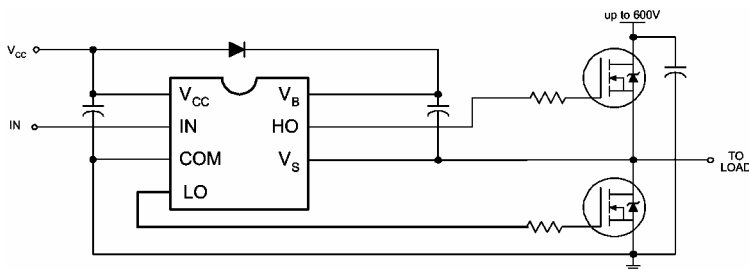

IR2104, IR2104S, IR2109, IR2109S, IR2184, IR2184S

IR2104, IR2104S IR2109, IR2109S

IR2184, IR2184S IR2184, IR2184S

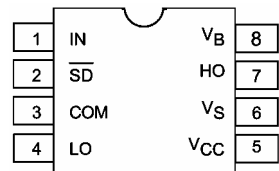
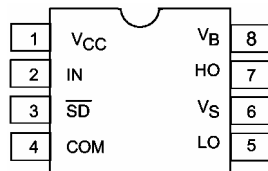
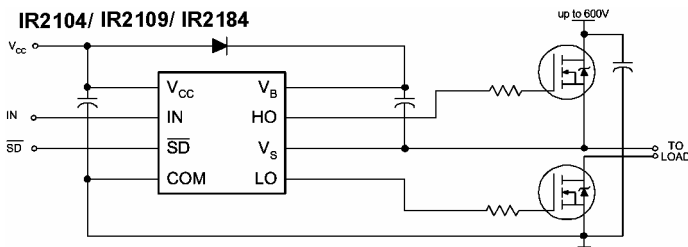

IR21091, IR21091S

IR21091, IR21091S

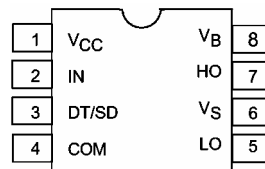
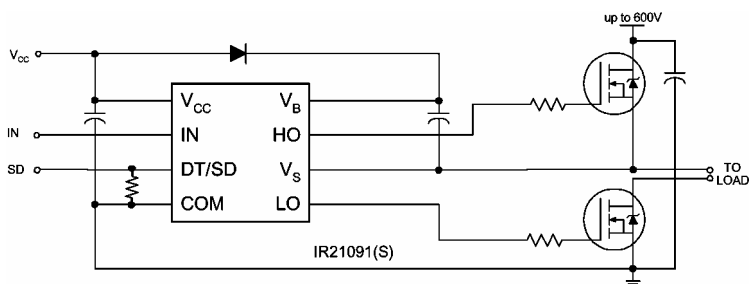

IR21094, IR21094S, IR21844, IR21844S

IR21094, IR21094S

IR21844, IR21844S

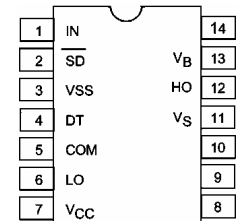
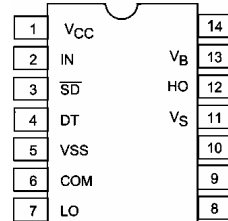
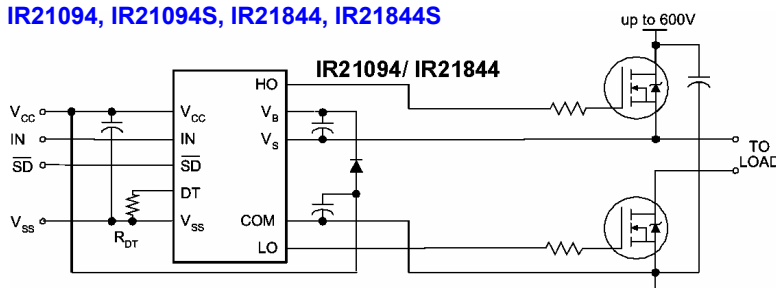

IO – budiče MOS a IGBT**budič pro H-můstek IR3220 - (plně chráněný H můstek pro řízení stejnosměrných motorů)**

IR3220 je plně chráněný dvojitý horní výkonový spínač doplněný o dva budiče dolních spínačů (předpokládá se doplnění externí dvojicí FETů). IR3220 je vybaven tepelnou ochranou, nadproudovou ochranou, ESD ochranou a diagnostikou stavu. Obvod umožňuje plné řízení H můstku včetně PWM soft-startu. Pomocí vstupů IN1 a IN2 lze vybrat pracovní režim a sekvenci PWM soft-start cyklů v koordinaci s omezením zatěžovacích rázů motoru prostřednictvím aktivních dolních spínačů. Při použití doporučených obvodových součástek a řádného chlazení je prostřednictvím vnitřních inteligentních spínačů zajištěna ochrana celého H můstku. Soft-start sekvence je programována nastavením časové konstanty RC a obnovuje se automaticky.

$R_{ds(on) \max}$ 12 m Ω

U_{CC} 5.5 až 35 V

I_{SD} 30 A

f_{max} 20 kHz

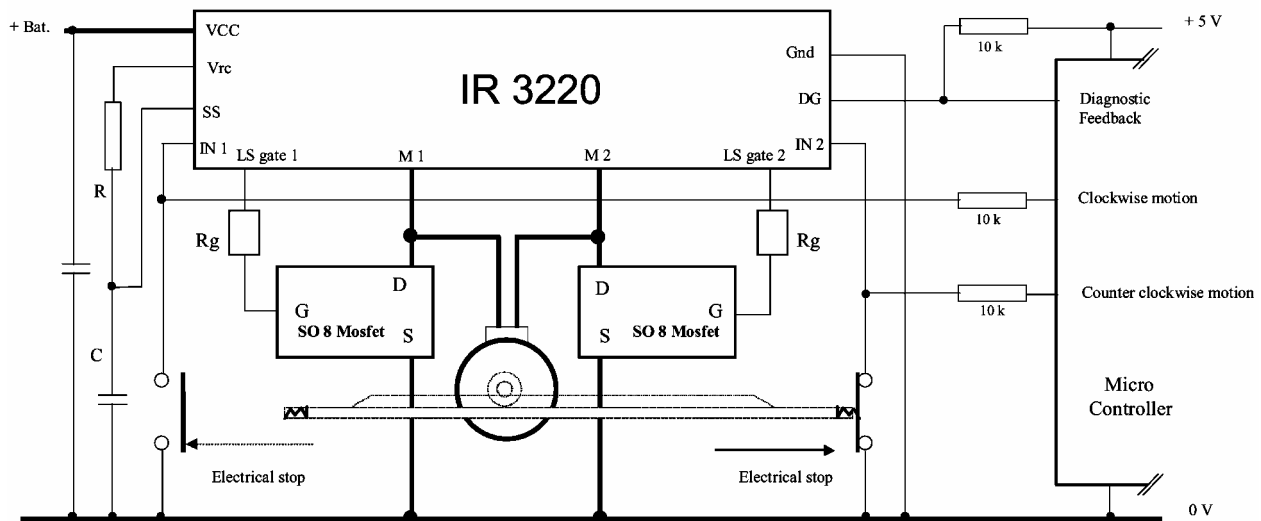
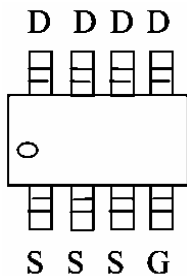
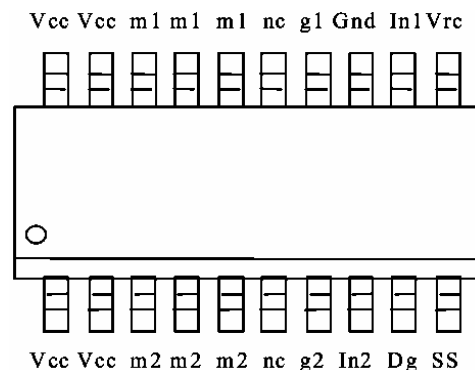
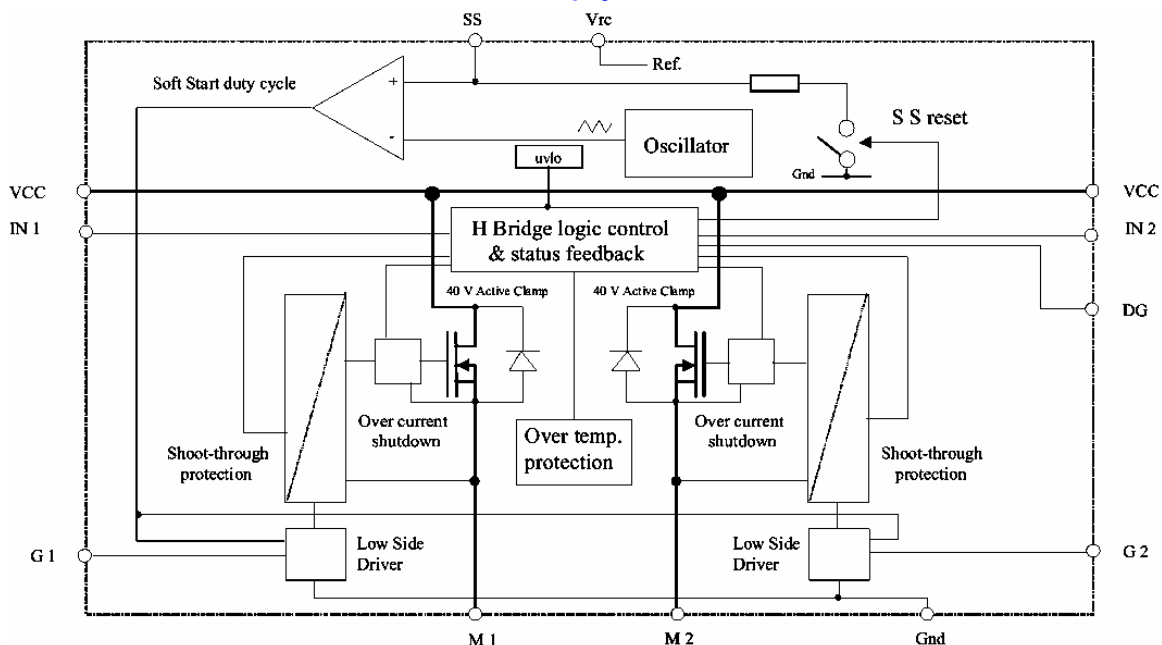
typické obvodové zapojení**IRF7474****IR3220****vnitřní blokové zapojení obvodu IR3220**

IO – budiče MOS a IGBT**budiče pro 3f můstek (3horní & 3dolní spinače)**

označení	pouzdro	V _{RRM} max [V]	I _{OUT} zdroj min [mA]	I _{OUT} zátěž min [mA]	U _{OUT} min [V]	U _{OUT} max [V]	U _{CC} min [V]	U _{CC} max [V]	U _{IN} "1" min [V]	U _{IN} "0" max [V]	t _{ON} typ [ns]	t _{rise} typ [ns]	t _{OFF} typ [ns]	t _{fall} typ [ns]	MT max [ns]	DT typ [ns]	speciální funkce
IR2130	DIP-28	600	200	420	10	20	-0.3	25	2.2	0.8	675	80	425	35		2.5	UV, CS
IR2130S	SOIC-28	600	200	420	10	20	-0.3	25	2.2	0.8	675	80	425	35		2.5	UV, CS
IR2130J	PLCC-44	600	200	420	10	20	-0.3	25	2.2	0.8	675	80	425	35		2.5	UV, CS
IR2131	DIP-28	600	200	420	10	20	-0.3	25	2.2	0.8	1.3	80	0.6	40		700	UV, CS, SD
IR2131S	SOIC-28	600	200	420	10	20	-0.3	25	2.2	0.8	1.3	80	0.6	40		700	UV, CS, SD
IR2131J	PLCC-44	600	200	420	10	20	-0.3	25	2.2	0.8	1.3	80	0.6	40		700	UV, CS, SD
IR2132	DIP-28	600	200	420	10	20	-0.3	25	2.2	0.8	675	80	425	35		0.8	UV, CS
IR2132S	SOIC-28	600	200	420	10	20	-0.3	25	2.2	0.8	675	80	425	35		0.8	UV, CS
IR2132J	PLCC-44	600	200	420	10	20	-0.3	25	2.2	0.8	675	80	425	35		0.8	UV, CS
IR2133	DIP-28	600	200	420	10	20	-0.3	25	2.2	0.8	750	90	700	40		250	UV, CS, SD
IR2133S	SOIC-28	600	200	420	10	20	-0.3	25	2.2	0.8	750	90	700	40		250	UV, CS, SD
IR2133J	PLCC-44	600	200	420	10	20	-0.3	25	2.2	0.8	750	90	700	40		250	UV, CS, SD
IR2135	DIP-28	600	200	420	10	20	-0.3	25	2.2	0.8	750	90	700	40		250	UV, CS, SD
IR2135S	SOIC-28	600	200	420	10	20	-0.3	25	2.2	0.8	750	90	700	40		250	UV, CS, SD
IR2135J	PLCC-44	600	200	420	10	20	-0.3	25	2.2	0.8	750	90	700	40		250	UV, CS, SD
IR2136	DIP-28	600	120	250	10	20	-0.3	25	3	0.8	400	110	380	50	80	250	UV, CS, SD
IR2136S	SOIC-28	600	120	250	10	20	-0.3	25	3	0.8	400	110	380	50	80	250	UV, CS, SD
IR2136J	PLCC-44	600	120	250	10	20	-0.3	25	3	0.8	400	110	380	50	80	250	UV, CS, SD
IR21362	DIP-28	600	120	250	10	20	-0.3	25	3	0.8	400	110	380	50	80	250	UV, CS, SD
IR21362S	SOIC-28	600	120	250	10	20	-0.3	25	3	0.8	400	110	380	50	80	250	UV, CS, SD
IR21362J	PLCC-44	600	120	250	10	20	-0.3	25	3	0.8	400	110	380	50	80	250	UV, CS, SD
IR21363	DIP-28	600	120	250	10	20	-0.3	25	3	0.8	400	110	380	50	80	250	UV, CS, SD
IR21363S	SOIC-28	600	120	250	10	20	-0.3	25	3	0.8	400	110	380	50	80	250	UV, CS, SD
IR21363J	PLCC-44	600	120	250	10	20	-0.3	25	3	0.8	400	110	380	50	80	250	UV, CS, SD
IR2137J	PLCC-68	600	220	460	12.5	20	-0.3	25	3.15	0.8	400	115	400	25	75	300	UV+CS+SD+B
IR2137Q	MQFP-64	600	220	460	12.5	20	-0.3	25	3.15	0.8	400	115	400	25	75	300	UV+CS+SD+B
IR2233	DIP-28	1200	200	420	10	20	-0.3	25	2.2	0.8	750	90	700	40	80	250	UV, CS, SD
IR2233S	SOIC-28	1200	200	420	10	20	-0.3	25	2.2	0.8	750	90	700	40	80	250	UV, CS, SD
IR2233J	PLCC-44	1200	200	420	10	20	-0.3	25	2.2	0.8	750	90	700	40	80	250	UV, CS, SD
IR2235	DIP-28	1200	200	420	10	20	-0.3	25	2.2	0.8	750	90	700	40	80	250	UV, CS, SD
IR2235S	SOIC-28	1200	200	420	10	20	-0.3	25	2.2	0.8	750	90	700	40	80	250	UV, CS, SD
IR2235J	PLCC-44	1200	200	420	10	20	-0.3	25	2.2	0.8	750	90	700	40	80	250	UV, CS, SD

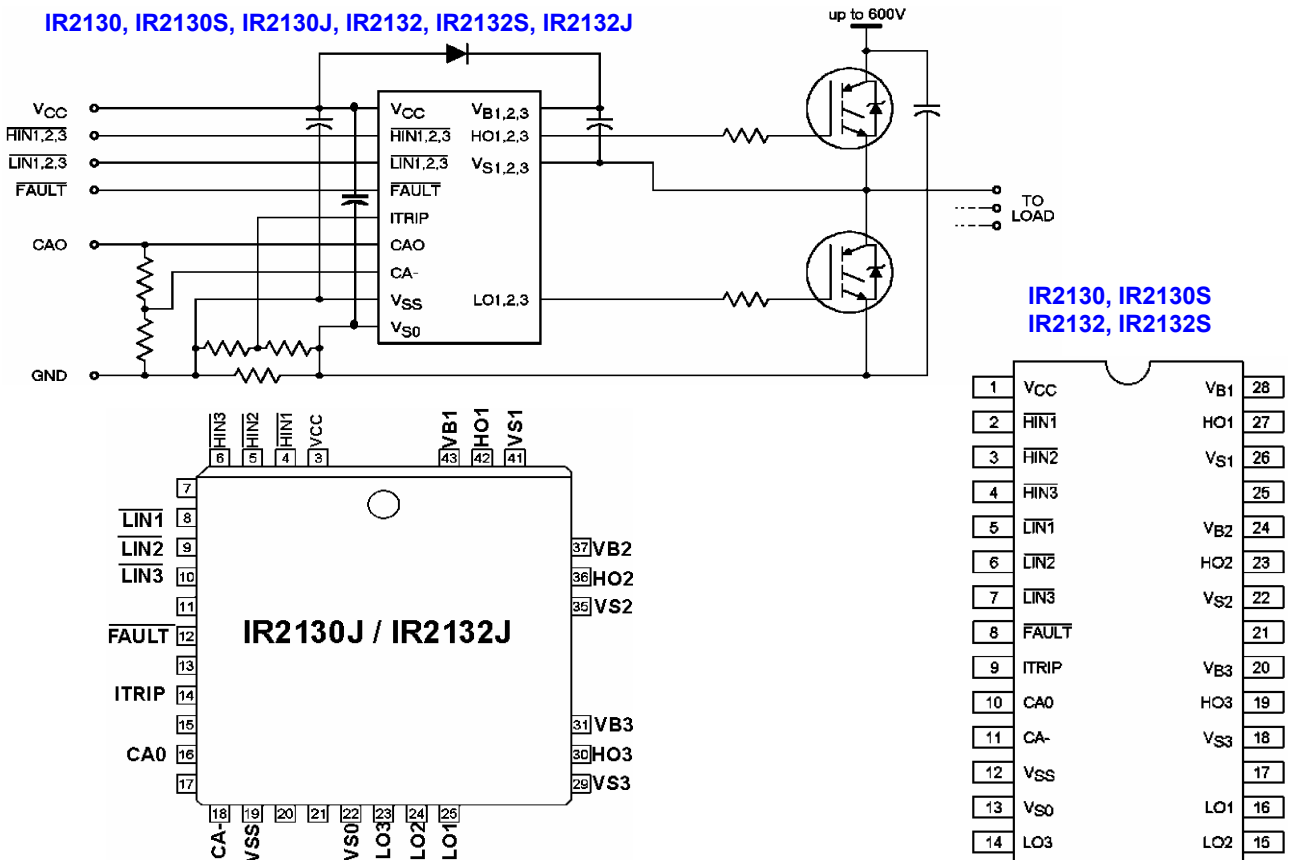
IR2130, IR2130S, IR2130J, IR2132, IR2132S, IR2132J

IO – budiče MOS a IGBT

budiče pro 3f můstek (3horní & 3dolní spínače)

IR2131, IR2131S, IR3131J

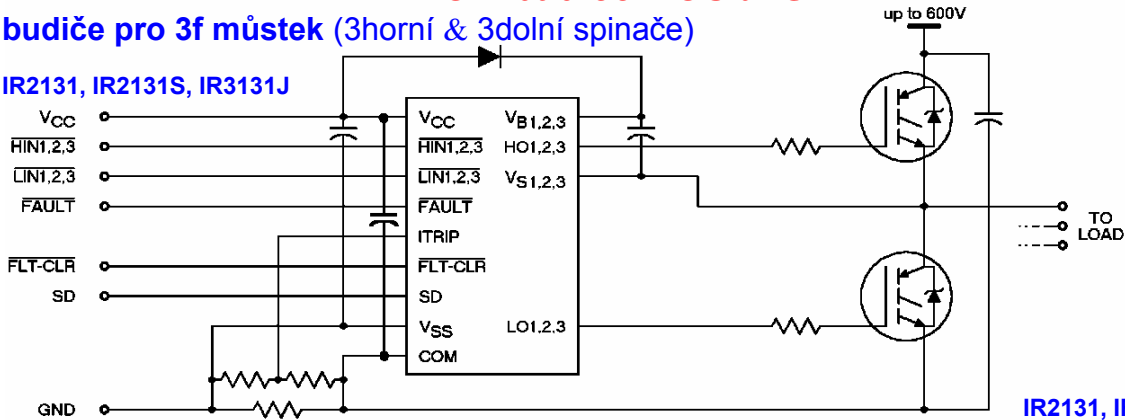

IR2131, IR2131S

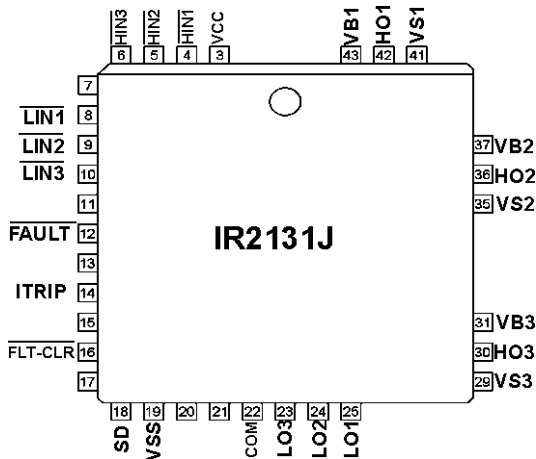

1	VCC	VB1	28
2	HIN1	HO1	27
3	HIN2	VS1	26
4	HIN3		25
5	LIN1	VB2	24
6	LIN2	HO2	23
7	LIN3	VS2	22
8	FAULT		21
9	ITRIP	VB3	20
10	FLT-CLR	HO3	19
11	SD	VS3	18
12	VSS		17
13	COM	LO1	16
14	LO3	LO2	15

IR2133, IR2133S, IR2133J, IR2135, IR2135S, IR2135J
IR2233, IR2233S, IR2233J, IR2235, IR2235S, IR2235J

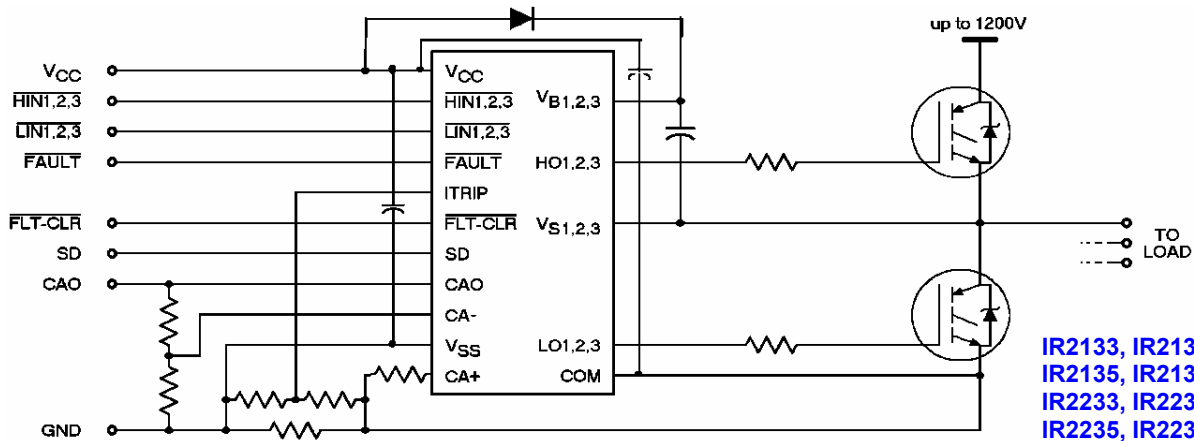

IR2133, IR2133S
IR2135, IR2135S
IR2233, IR2233S
IR2235, IR2235S

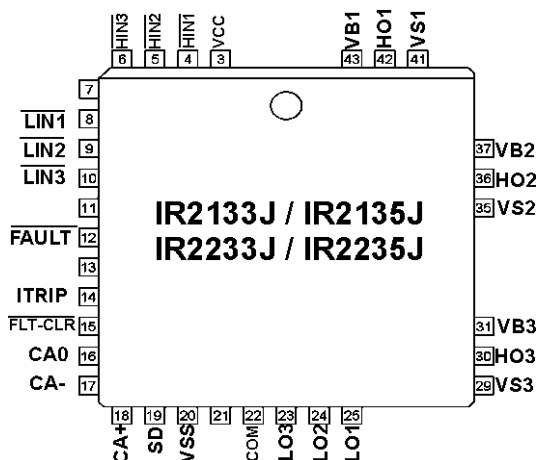

1	ITRIP	FAULT	28
2	FLT-CLR	LIN3	27
3	CAO	LTN2	26
4	CA-	LIN1	25
5	CA+	HIN3	24
6	SD	HIN2	23
7	VSS	HIN1	22
8	COM	VCC	21
9	LO3	VB1	20
10	LO2	HO1	19
11	LO1	VS1	18
12	VS3	VB2	17
13	HO3	HO2	16
14	VB3	VS2	15

IO – budiče MOS a IGBT

budiče pro 3f můstek (3horní & 3dolní spinače)

IR2136, IR2136S
IR2136J, IR2136Z
IR21362S, IR21362J

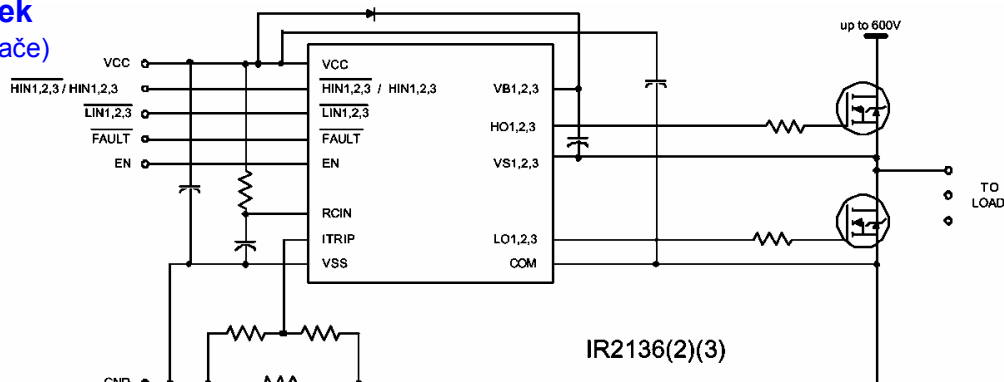

IR2136, IR2136S
IR21362, IR21362S

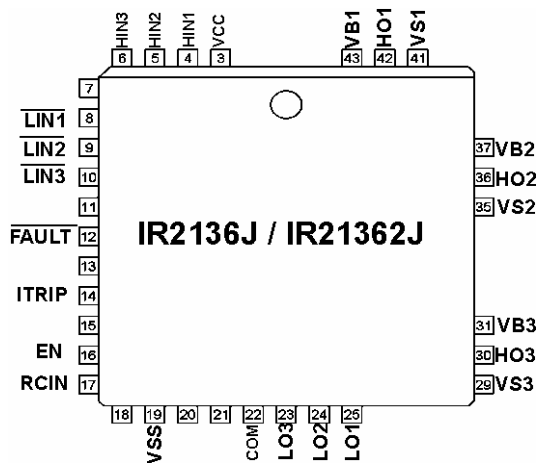
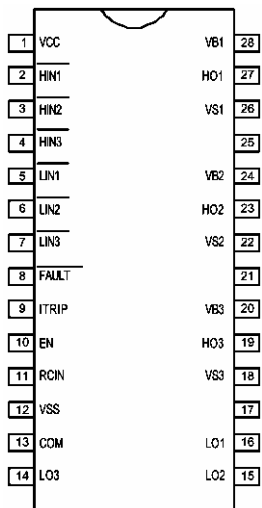

IR2137J, IR2137Q, IR2237J, IR2237Q

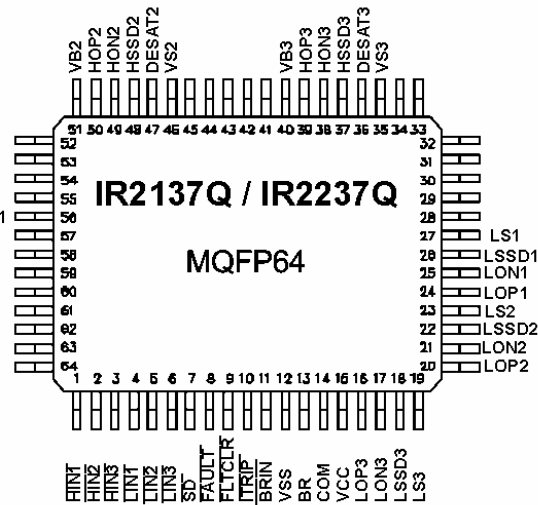
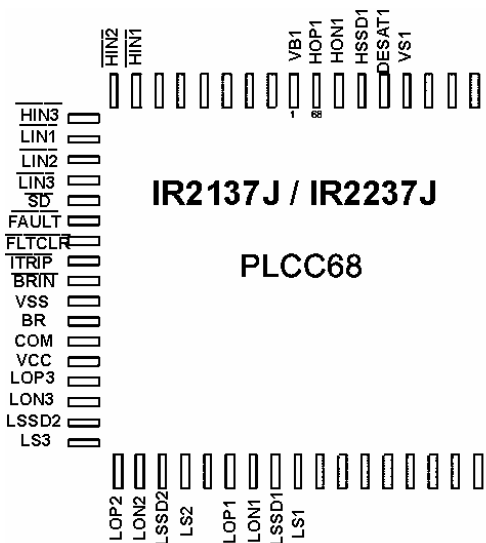
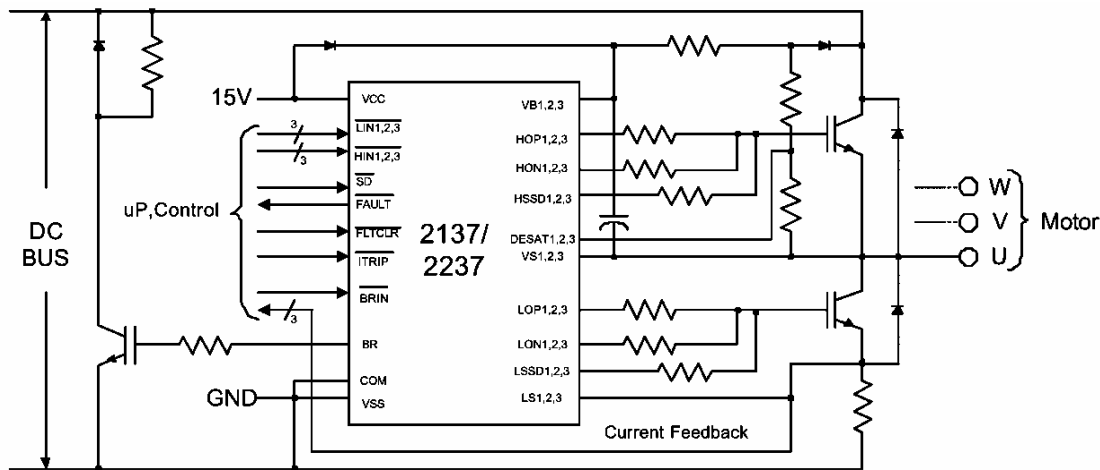

IO – budiče MOS a IGBT

budiče pro elektronické předřadníky

$U_{CLAMP} \min = 15.6V$

$V_{RRM} \max = 600V$

označení	pouzdro	I_{OUT} zdroj min [mA]	I_{OUT} zátěž min [mA]	f_{osc} typ [kHz]	@ R_T [k Ω]	t_{rise} typ [ns]	t_{fall} typ [ns]	DT typ [ns]	poznámka
IR2151	DIP-8	100	210	20	35.7	80	40	1200	pro nové konstrukce doporučen typ IR2153, IR21531
IR2151S	SOIC-8	100	210	20	35.7	80	40	1200	pro nové konstrukce doporučen IR2153S, IR21531S
IR2152	DIP-8	100	210	20	35.7	80	40	1200	připravuje se nový typ IR2154, IR21541
IR2152S	SOIC-8	100	210	20	35.7	80	40	1200	připravuje se nový typ IR2154S, IR21541S
IR2153	DIP-8	200	400	20	36.9	80	45	1200	perspektivní typ, pokračovatel řady IR2151 a IR2155
IR2153S	SOIC-8	200	400	20	36.9	80	45	1200	perspektivní typ, pokračovatel řady IR2151 a IR2155
IR21531	DIP-8	200	400	20	36.9	80	45	600	perspektivní typ, pokračovatel řady IR2151 a IR2155
IR21531S	SOIC-8	200	400	20	36.9	80	45	600	perspektivní typ, pokračovatel řady IR2151 a IR2155
IR2155	DIP-8	210	420	20	35.7	80	40	1200	pro nové konstrukce doporučen typ IR2153, IR21531
IR2156	DIP-14	500	500	25	33	110	55	2000	programovatelné nažhavení (čas a frekvence)
IR2156S	SOIC-16n	500	500	25	33	110	55	2000	programovatelné nažhavení (čas a frekvence)
IR2157	DIP-16	500	500	30	32	85	45	2000	nejlépe vybavený budič pro el. předřadníky bez PFC
IR2157S	SOIC-16n	500	500	30	32	85	45	2000	nejlépe vybavený budič pro el. předřadníky bez PFC
IR21571	DIP-16	500	500	30	32	85	45	2000	nejlépe vybavený budič pro el. předřadníky bez PFC
IR21571S	SOIC-16n	500	500	30	32	85	45	2000	nejlépe vybavený budič pro el. předřadníky bez PFC
IR2159	DIP-16	500	500	25+95	39+10	150	100	1800	budič pro el. předřadník s funkcí stmívání a ochranami
IR2159S	SOIC-16n	500	500	25+95	39+10	150	100	1800	budič pro el. předřadník s funkcí stmívání a ochranami
IR21591	DIP-16	500	500	30+230	68+10	150	100	1000	budič pro el. předřadník s funkcí stmívání a ochranami
IR21591S	SOIC-16n	500	500	30+230	68+10	150	100	1000	budič pro el. předřadník s funkcí stmívání a ochranami
IR2167	DIP-20	500	500	30	32	85	45	2000	nejlépe vybavený budič pro el. předřadníky s PFC

IR2151, IR2151S, IR2152, IR2152S, IR2155

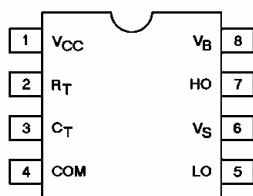
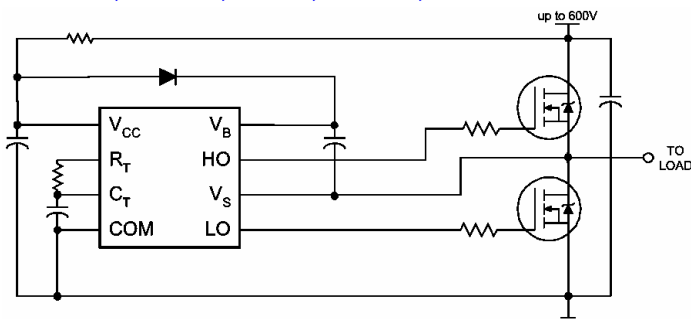

IR2153, IR2153S, IR21531, IR21531S

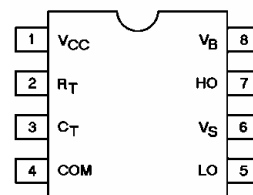
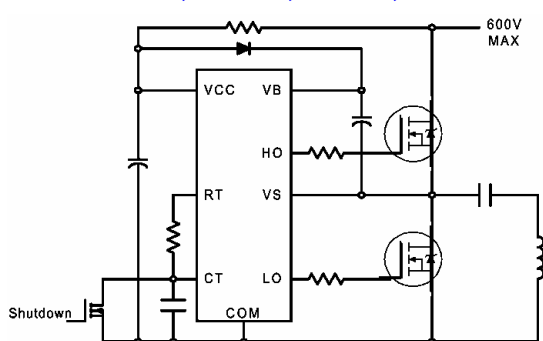

IR2156, IR2156S

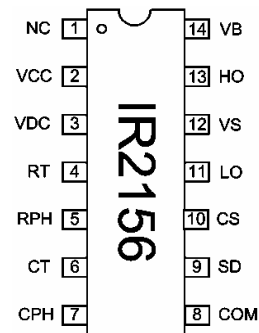
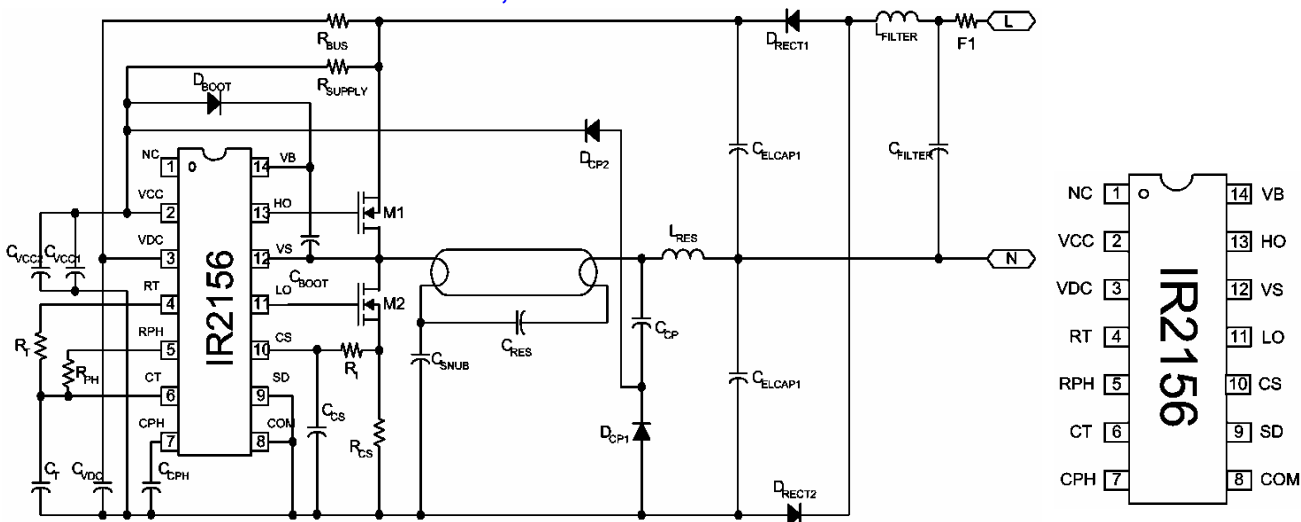

IO – budiče MOS a IGBT

budiče pro řízení synchronních usměrňovačů

označení	pouzdro	I _{OUT} zdroj min [mA]	I _{OUT} zátěž min [mA]	U _{OUT} max [V]	U _{DD} max [V]	T _A min [°C]	T _A max [°C]	f min [kHz]	f max [kHz]	t _{rise} typ [ns]	t _{fall} typ [ns]
IR1175S	SSOP-20	2000	2000	5	7	-40	85	100	2000	20	20
IR1176	DIP-20	4000	4000	5	7	-40	85	100	2000	20	20
IR1176S	SSOP-20	4000	4000	5	7	-40	85	100	2000	20	20
IR1176SS	SSOP-20	4000	4000	5	7	-40	85	100	2000	20	20

IR1175S, IR1176, IR1176S, IR1176SS (U_{out} < 5 V_{DC})

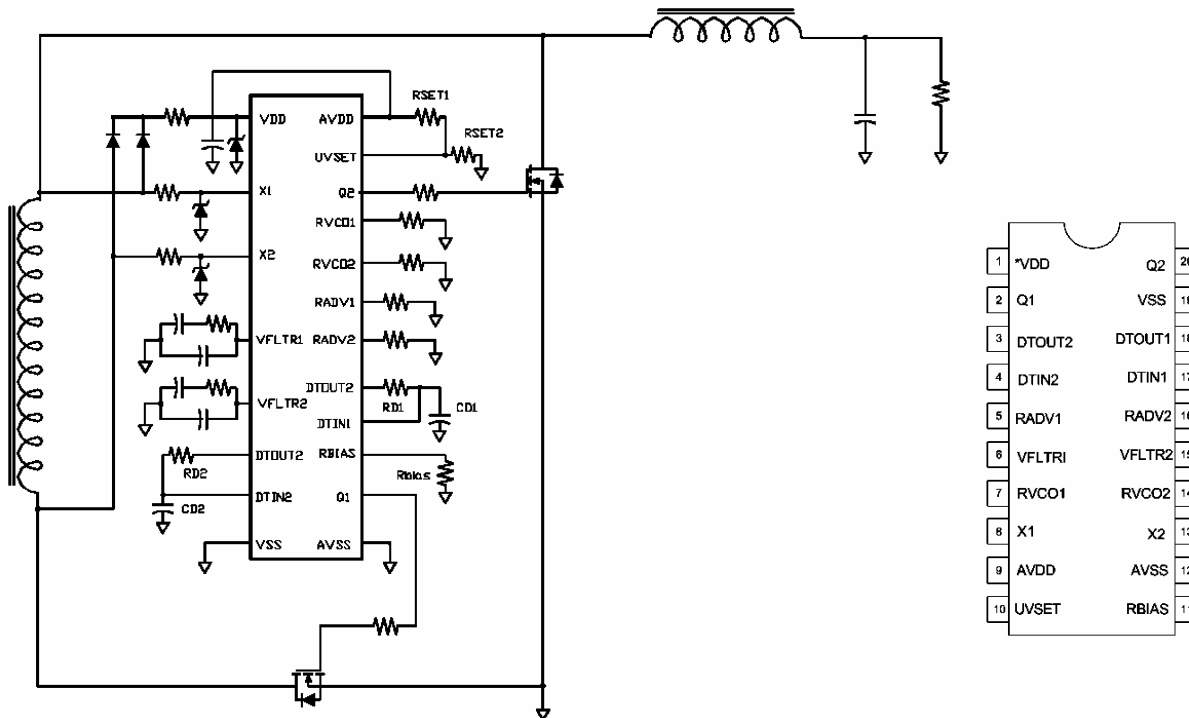

IR1175S, IR1176, IR1176S, IR1176SS (U_{out} = 5 V_{DC})

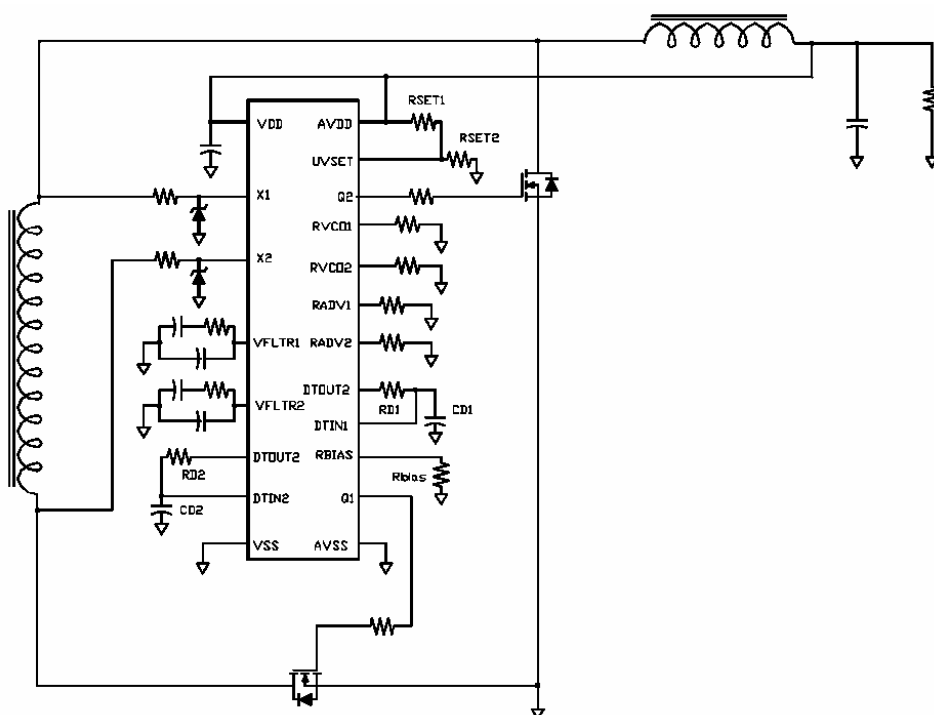

IO – budiče MOS a IGBT – pouzdra DIP

DIP-8

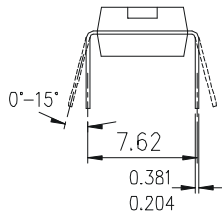
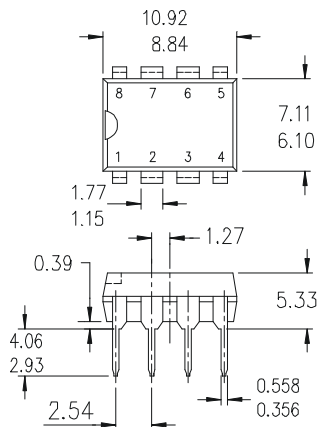

DIP-14

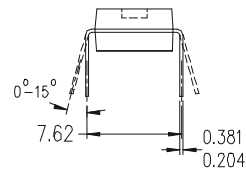
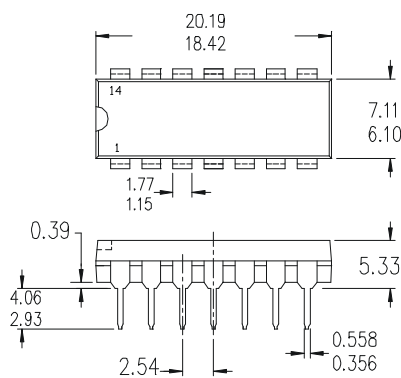

DIP14s-1

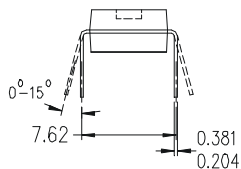
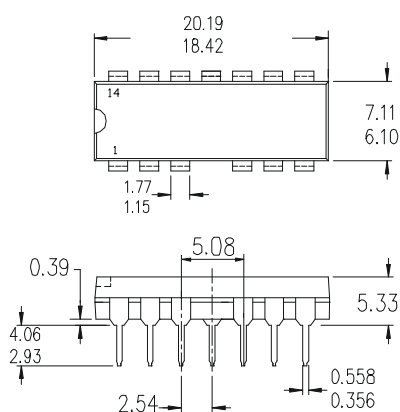

DIP-16

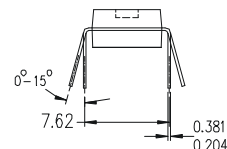
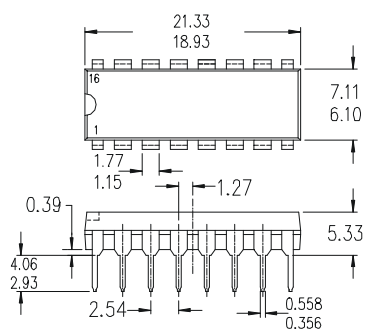

DIP16s-2

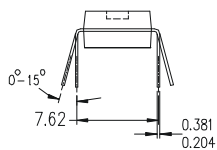
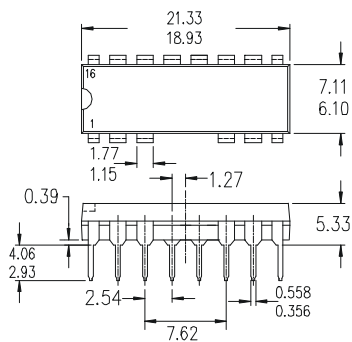

DIP-20

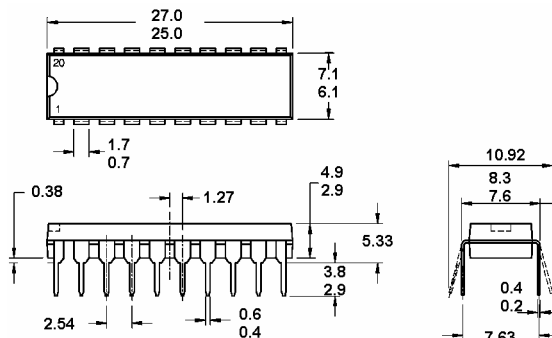

DIP-28

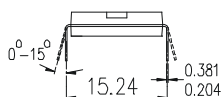
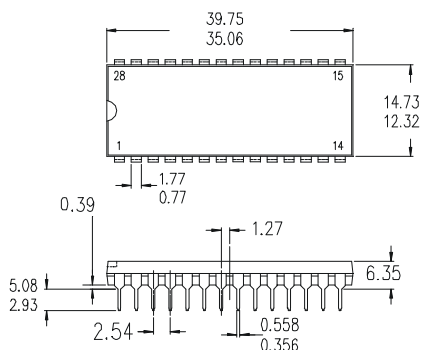

IO – budiče MOS a IGBT – pouzdra SMD

SOIC-8

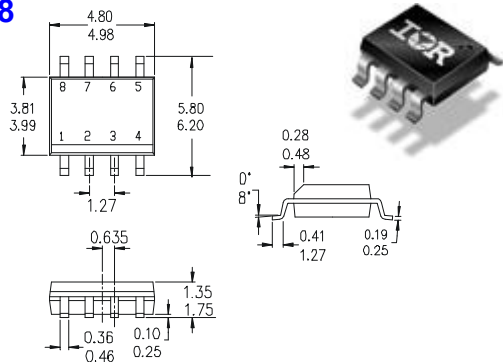

SOIC-14

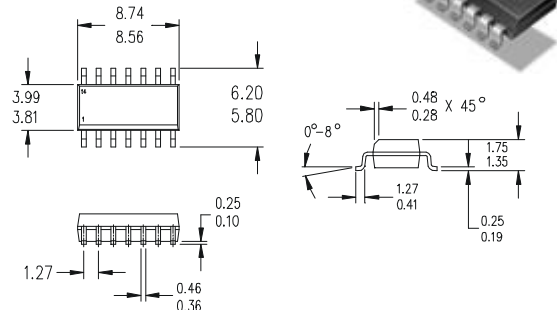

SOIC-16n

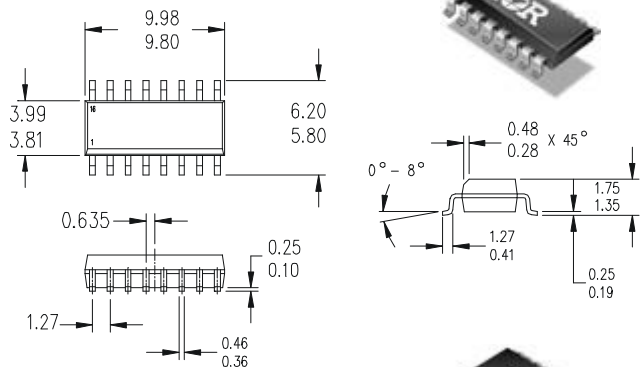

SOIC-16w

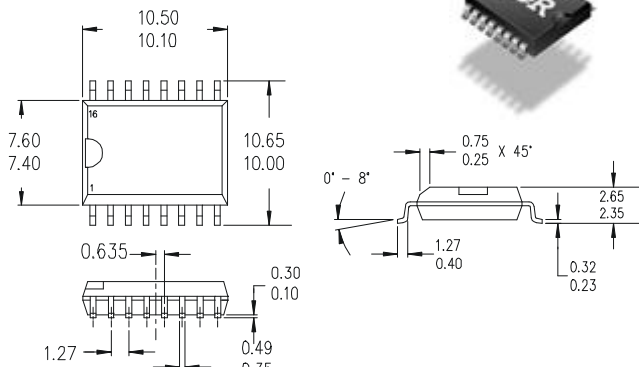

SSOP-20

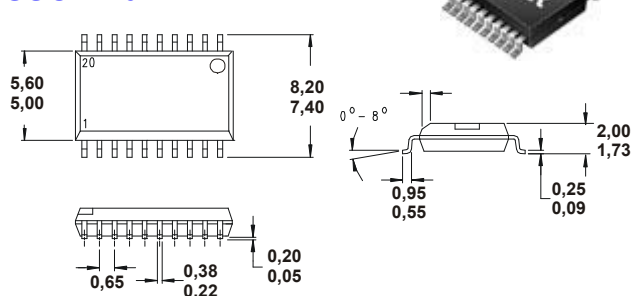

SOIC-28

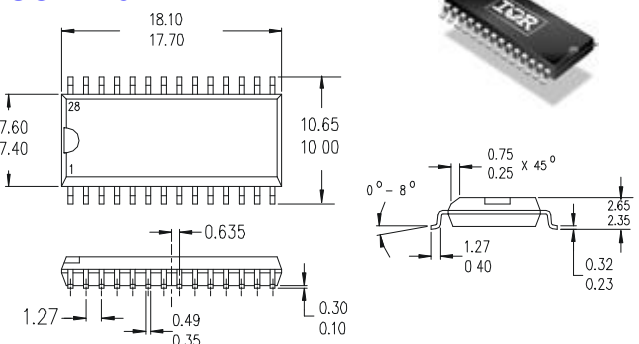

PLCC-44

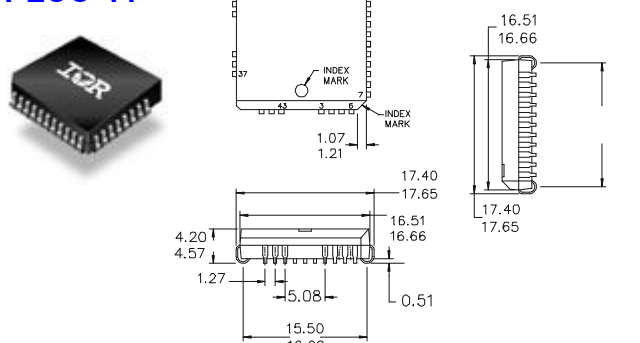

PLCC-68

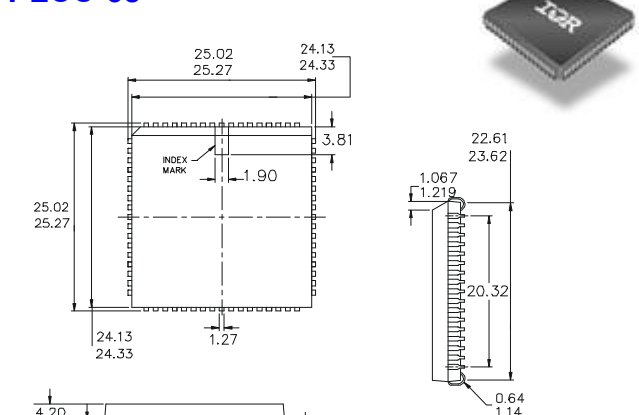

MQFP-64

