

Apogee Technology, Inc.

DDX[®]
Direct Digital Amplification



APPLICATIONS

October, 2002

Summary

- DDX Technology Overview
- DDX Products
 - DDX-8000
- DDX-8000 Demo
- Application Information
- Reference Boards

DDX Technology

- Traditional Amplifier Technology
 - Class A/B Designs
 - Analog
 - Low Efficiency
- High Efficiency Designs Emerged
 - Analog Class D Designs
 - Class G/H: Vary PS with Class A/B
- Development Goal
 - High Efficiency + Digital = DDX



DDX The New Standard

- Patented Amplifier Design
- All-Digital
 - Direct Interface to Digital Audio
 - IC Integration
- High Efficiency
 - 3 Times Higher Efficiency
 - Reduced Heat = Smaller Size/Package
 - Power Supply Savings

DDX Digital Design

Analog Amplifier

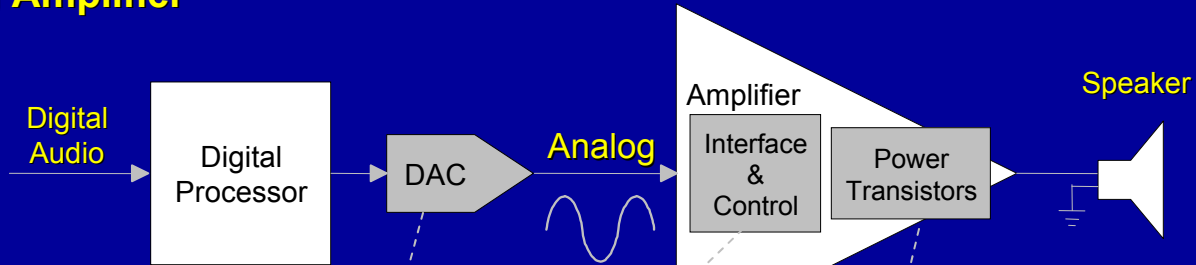

DAC = Digital to Analog Converter

Combine DAC
and Control

Utilize High
Efficiency Design

DDX Amplifier



DDX Eliminates DAC and Analog Signals

DDX Functional Diagram

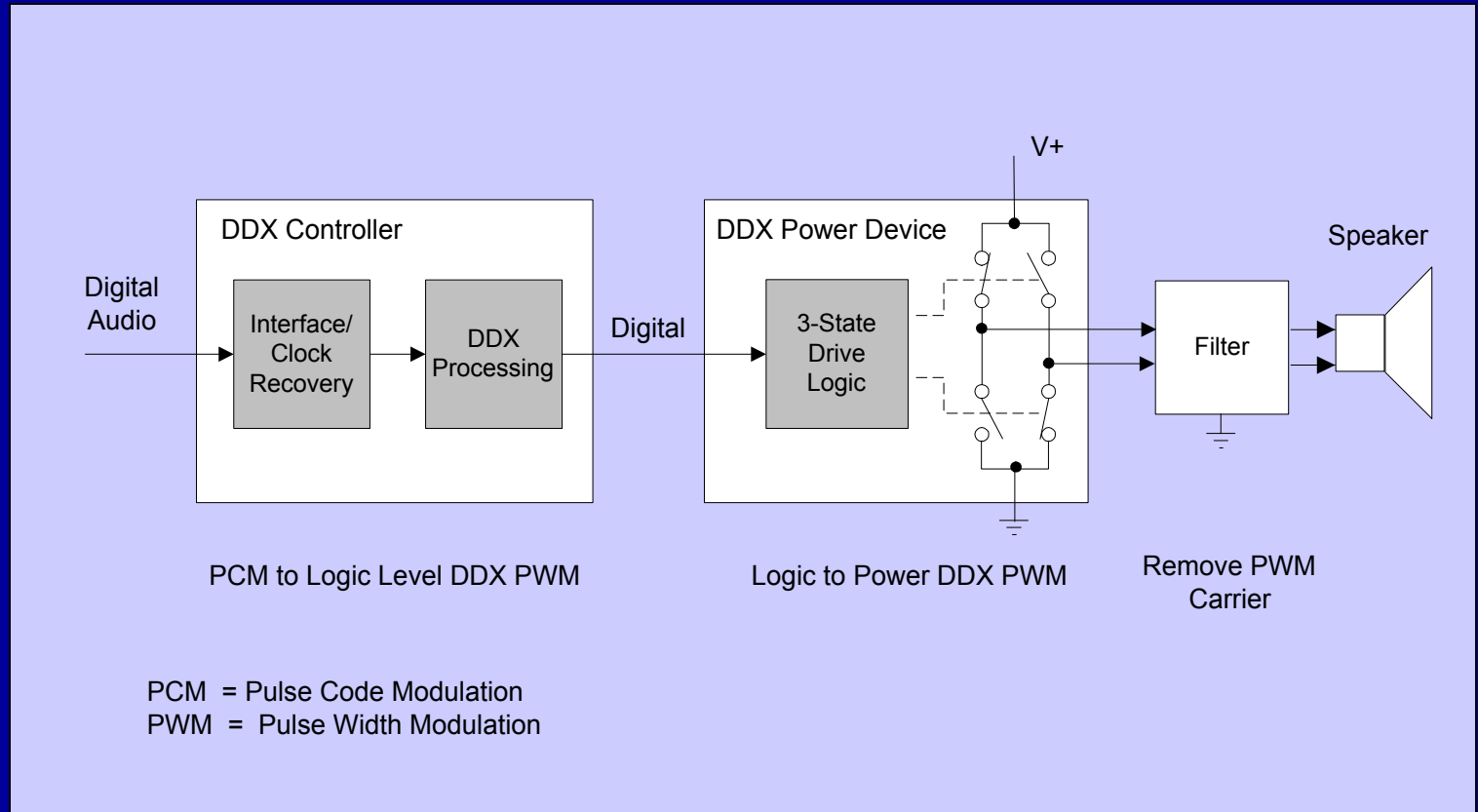

DDX Digital Control Of 3-State Power Stage

DDX Drive States

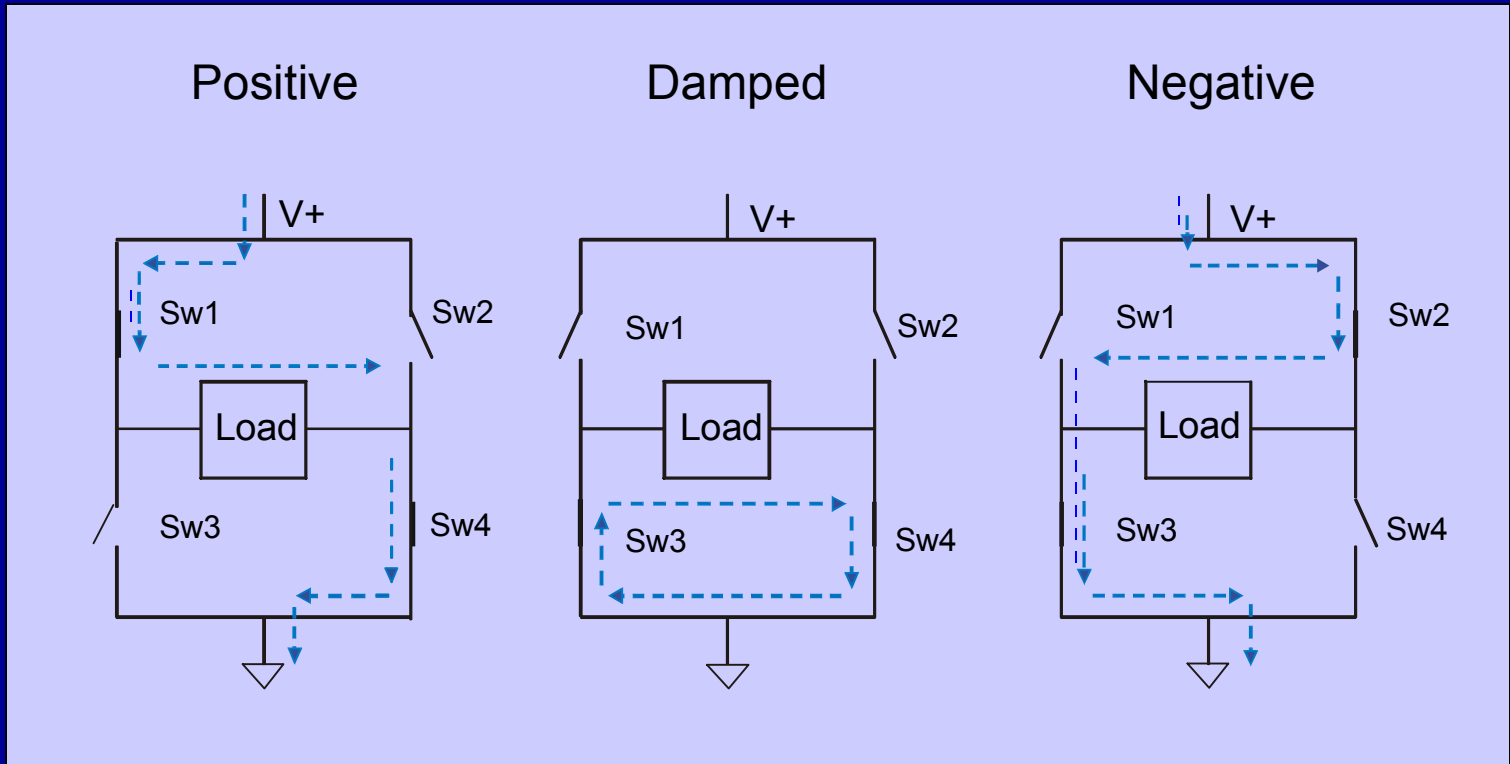

DDX Damped State Increase Efficiency and Lowers EMI Compared to Binary Designs

DDX 3-State Modulation

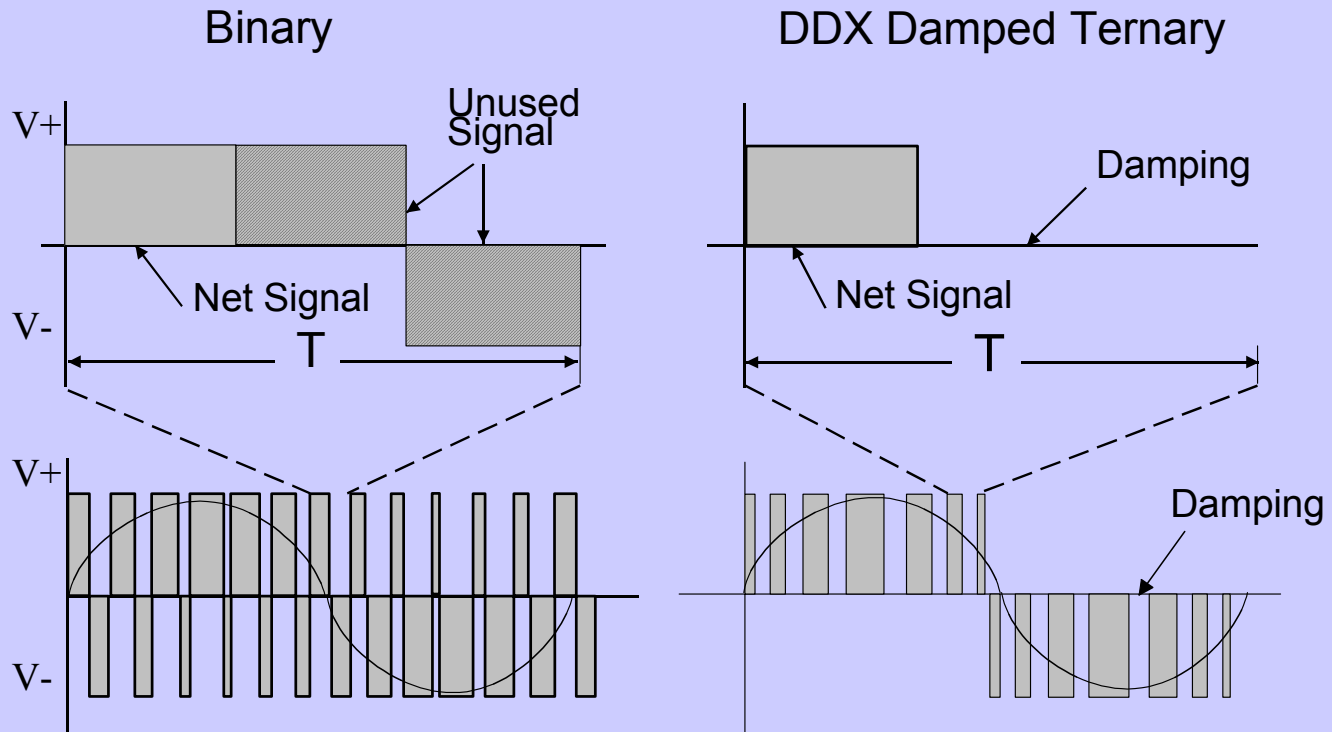

DDX Only Outputs a Signal When Required

DDX Efficiency Advantage

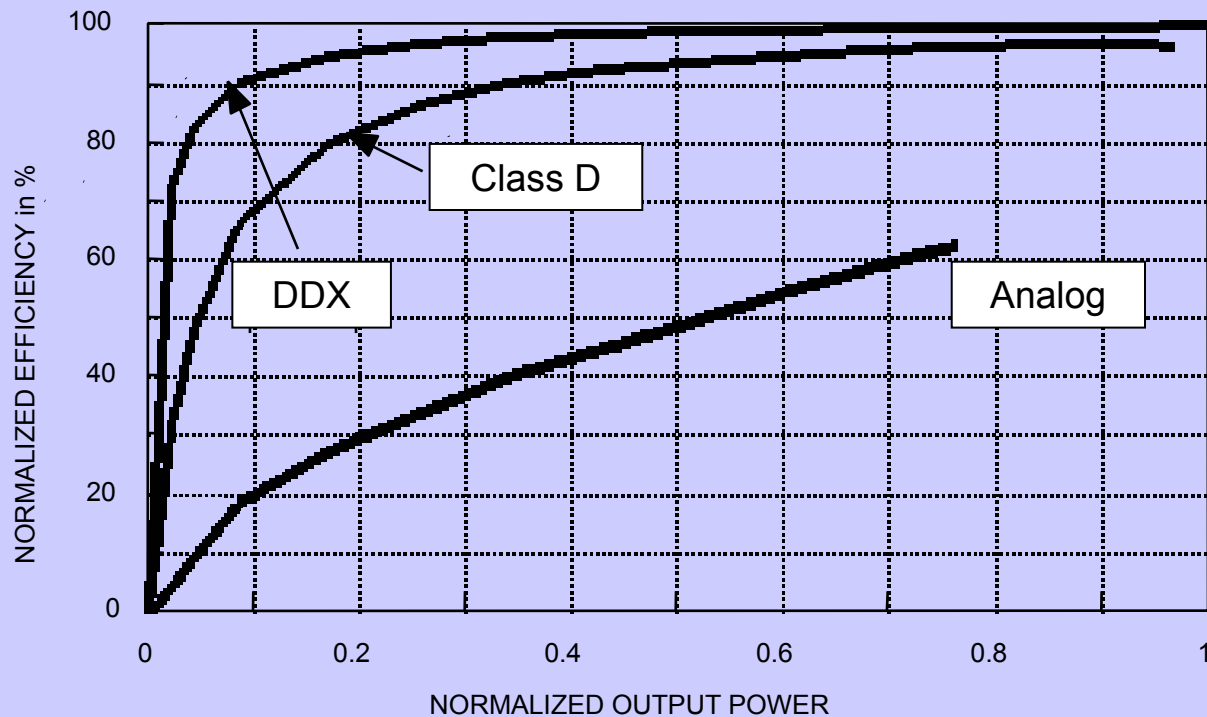

DDX Modulation Increases Class D Efficiency

DDX EMI/RFI Advantage

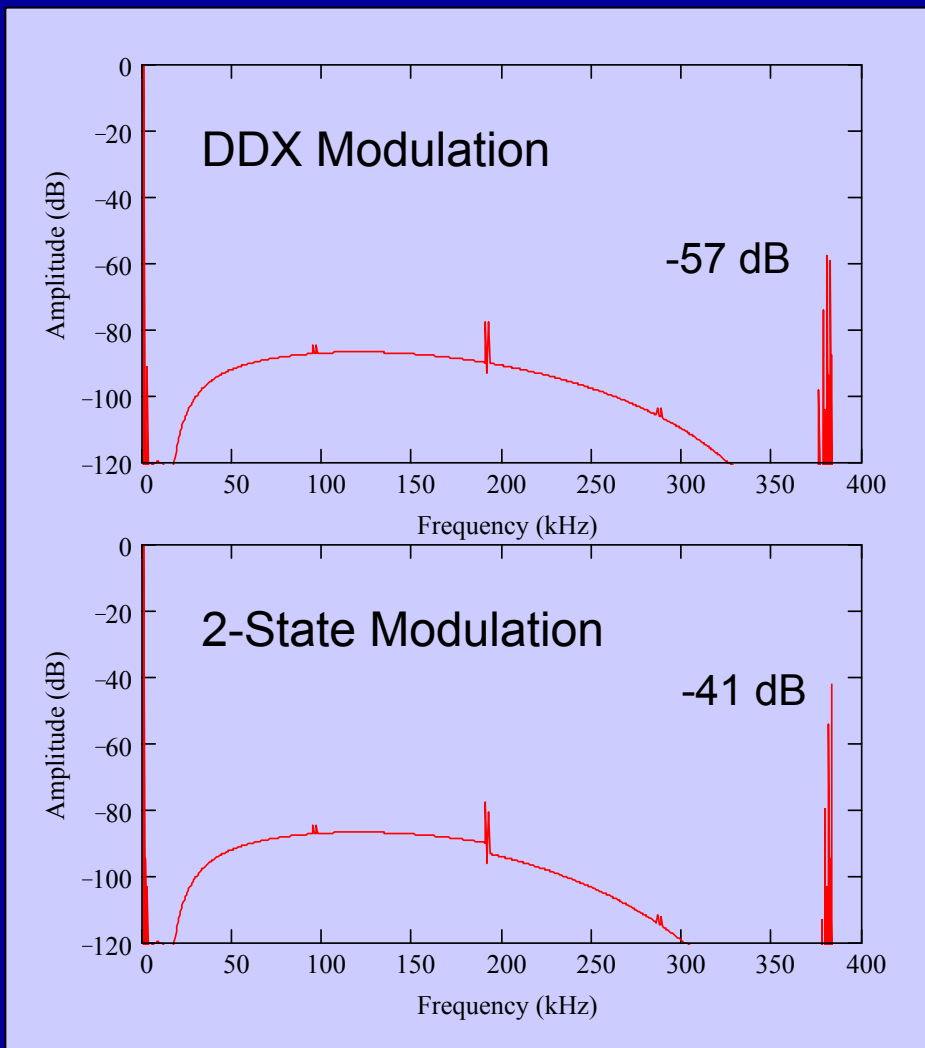

Theoretical Performance

- 0 dB, 1.0 kHz Input
- 30 kHz 2nd Order LPF

***DDX is 16 dB Lower
Carrier Than
2-State Modulation!***

DDX Low Cost Integration

Digital IC Process Improvements

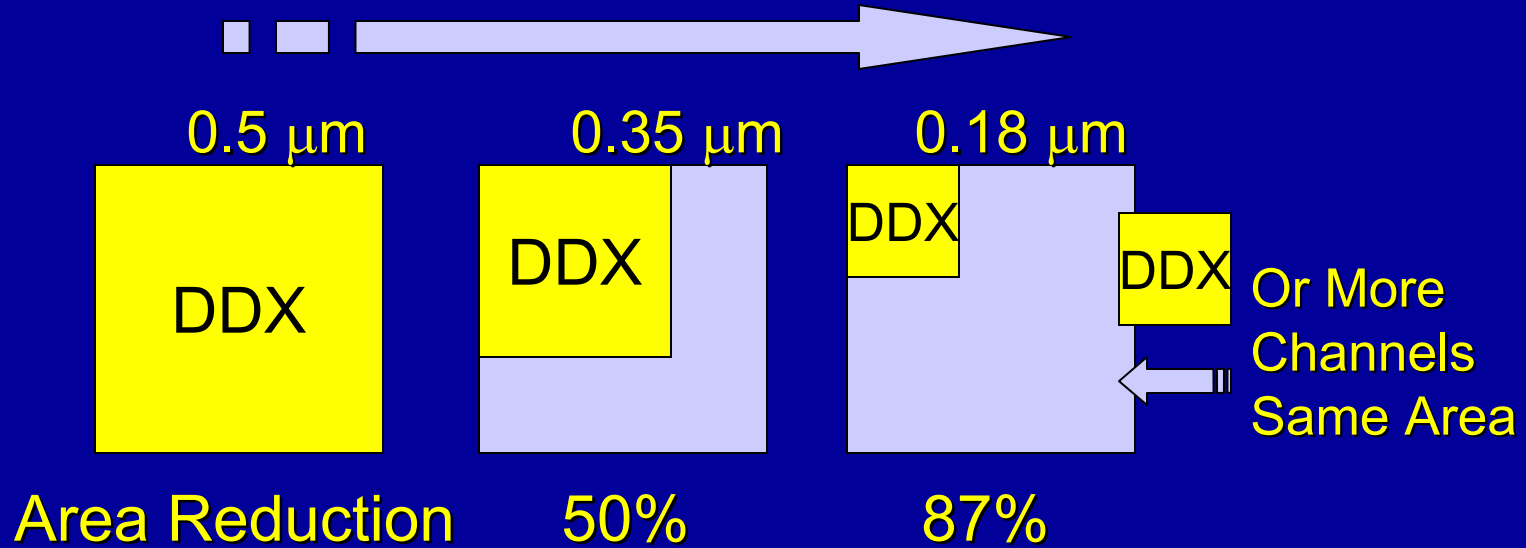

*DDX Area Reduces with IC Processes
Analog Designs DO NOT Follow Same Trend*

DDX-2060 Power IC

DDX[®] Power IC
2x35W



PowerSO36

Features

- **Output Power**
 - 2x35+W into 8W
 - 1x70+W into 4W
- **Single Supply (+10V to +28V)**
- **Efficiency 88%**
- **Short Circuit Protection**
- **Thermal Protection**
- **Power-down Mode**

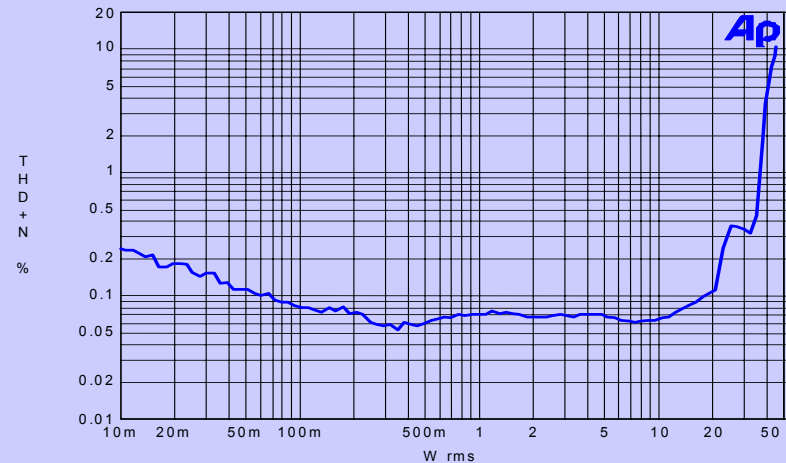

DDX-2100 Power IC

*50W Stereo DDX Power IC
Samples Q4'01*

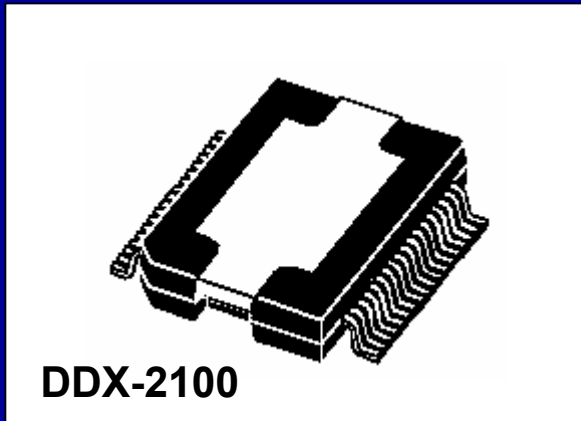

PowerSO36

Operation (with DDX-2000)

- Single Supply (+10V to +36V)
- Output Power
 - 2x50+ W into 8Ω
 - 1x100+ W into 4Ω
- Efficiency 88%
- Short Circuit Protection
- Thermal Protection
- Powerdown Mode

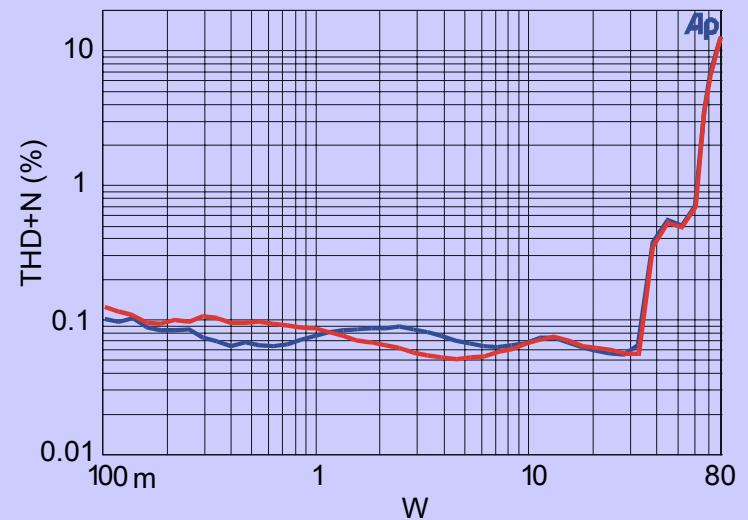

DDX-4100 Controller

*Multi-Channel Design
Providing Complete
End-to-End Digital Solution*



TQFP 44, 3.3V CMOS Device

FEATURES

Interface/Control

- 4 Channel Serial, ACLink, S/PDIF Inputs
 - 32kHz - 96kHz
- 4.1 Channel DDX Outputs
- 6 Channel Serial Output
- I2C Control

Enhanced Digital Audio Functions

- Volume Control
- Bass/Treble
- Parametric EQ
- Bass Management
- Automatic Mute
- Anti Clipping

DDX-4100 Processing

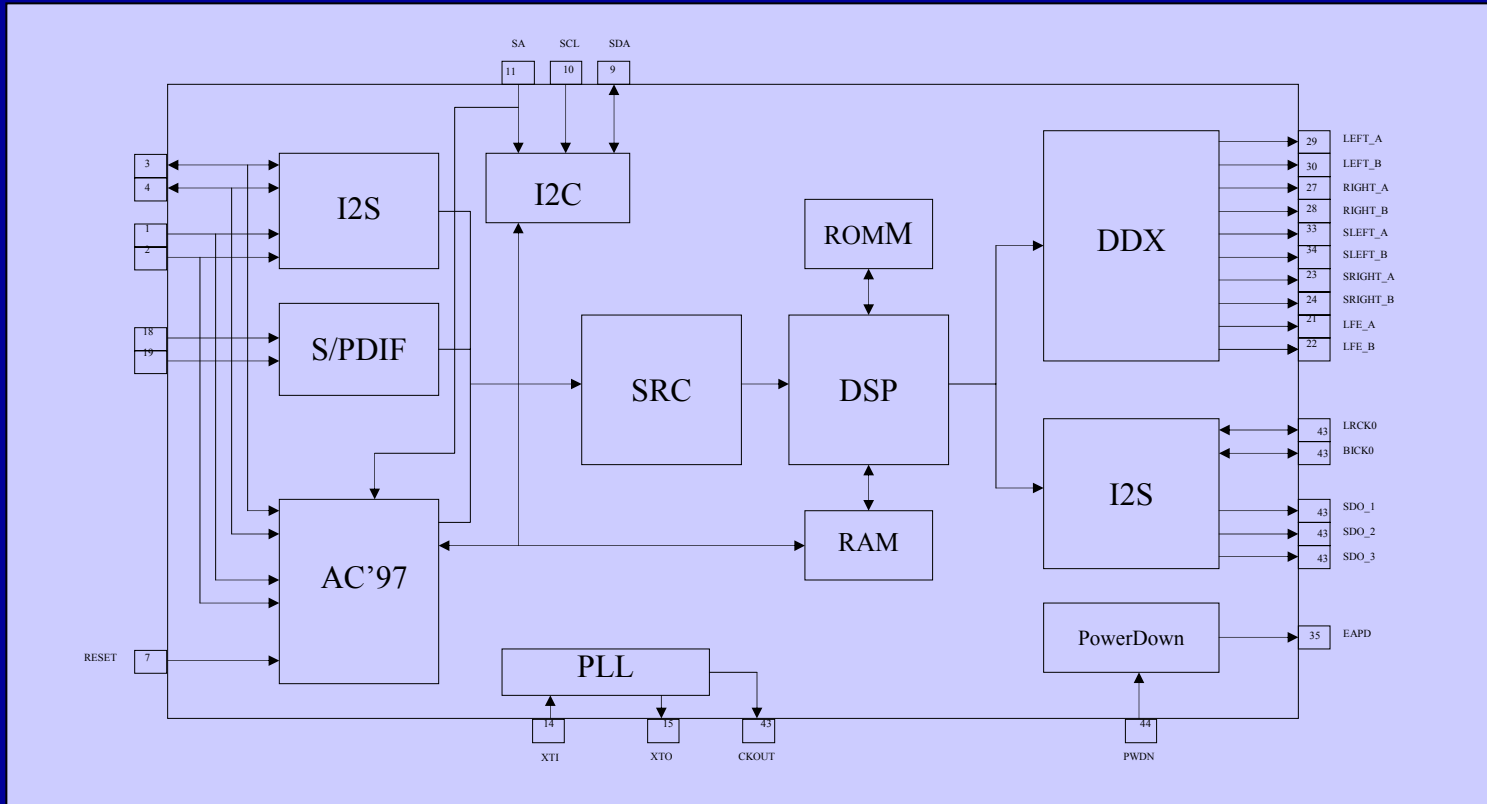

- Multiple Digital Interface Standards
- SRC Conversion to 48 kHz for DSP Operations
- 20 Bit DSP Performs Preamplifier and EQ Functions
- 5 Channel DDX + Serial Outputs

DDX Controller ICs

Parameter	DDX-8000	DDX-4100A	DDX-4100	DDX-2000
Core Design	24 bit	16 Bit	16 Bit	16 Bit
I/O and Control				
DDX Channels	8	4.1	4.1	2
I2S (Stereo)	4 In+4 Out	3 In + 3 Out	3 In + 3 Out	1 In
Clocking	Sync	SRC to 48kHz	SRC to 48kHz	Sync
Sample Rate	32 kHz to 192kHz	32kHz to 96kHz	32kHz to 96kHz	32kHz to 48kHz
I2C Control	Y	Y	Y	
Features				
Volume/Gain	-96dB to +24 dB	-80dB to +24 dB	-80dB to +9 dB	-96dB to +12 dB
Step Size	0.5 dB	1 dB	1 dB	0.75 dB
Tone (Bass/Treble)	+/- 12 dB, 2 dB Step	+/- 12 dB, 2 dB Step	+/- 12 dB, 2 dB Step	
EQ	5 per Chan (28 Bit, 192 kHz)	5 per Chan (20 Bit, 48 kHz)	4 per Chan (20 Bit, 48 kHz)	
Compressor	Programmable	Fixed	Fixed	Fixed
Limiter	Programmable			
Bass Management	Y	Partial	Partial	
Channel Mapping	Y			
Soft Mute	Y			
Hard Mute	Y	Y	Y	Y
Auto Mute	Y	Y	Y	Y
A/M Mode	Y			
Input Mixing	Y			



Apogee Technology, Inc.

DDX8000



Feature Set

- 8 Channels of 24-Bit DDX Processing
- 192 kHz Sample Rate for DVD-A
- 5 Bands 28-Bit EQ per Channel
- Soft Volume and Soft Mute
- Dual Programmable Limiters
- Bass-Management
- Bass/Treble Tone Control
- Zero-Input Detect Auto-Mute
- Channel Mapping
- AM Interference Reduction

Applications

- DVD Receiver
- AV Receiver
- Powered Speaker Systems
- Mini/Micro Compo Systems
- Automotive/Car
- Set-Top Box
- TV

Performance

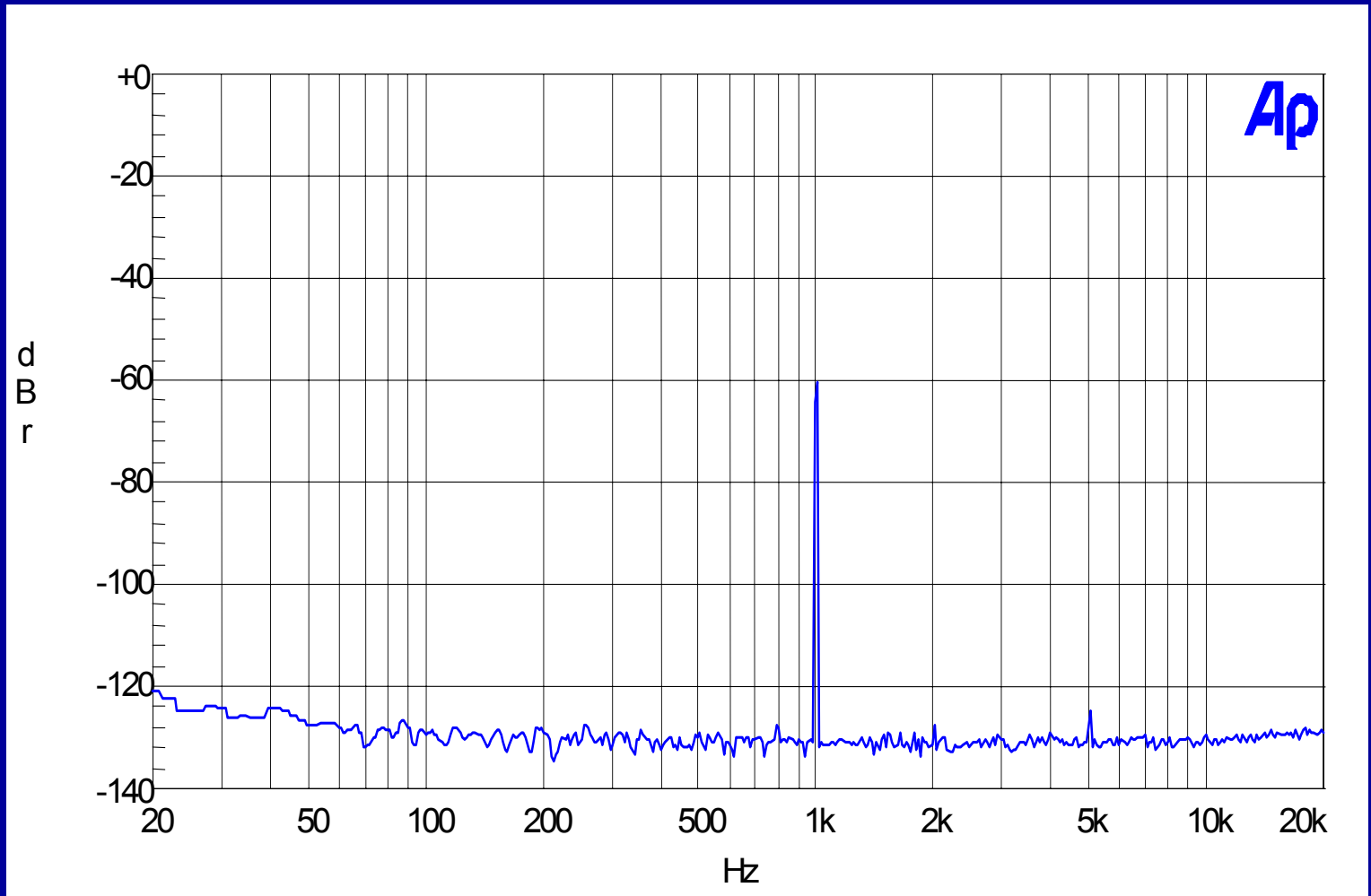

Dynamic Range >100dB

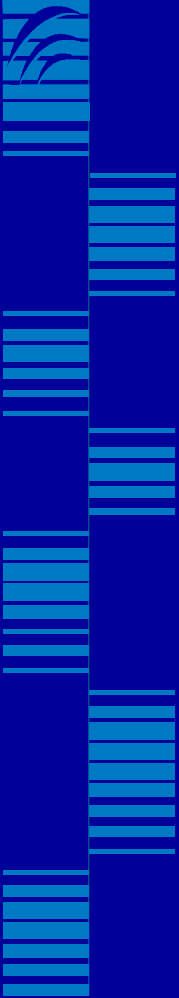

Signal Flow

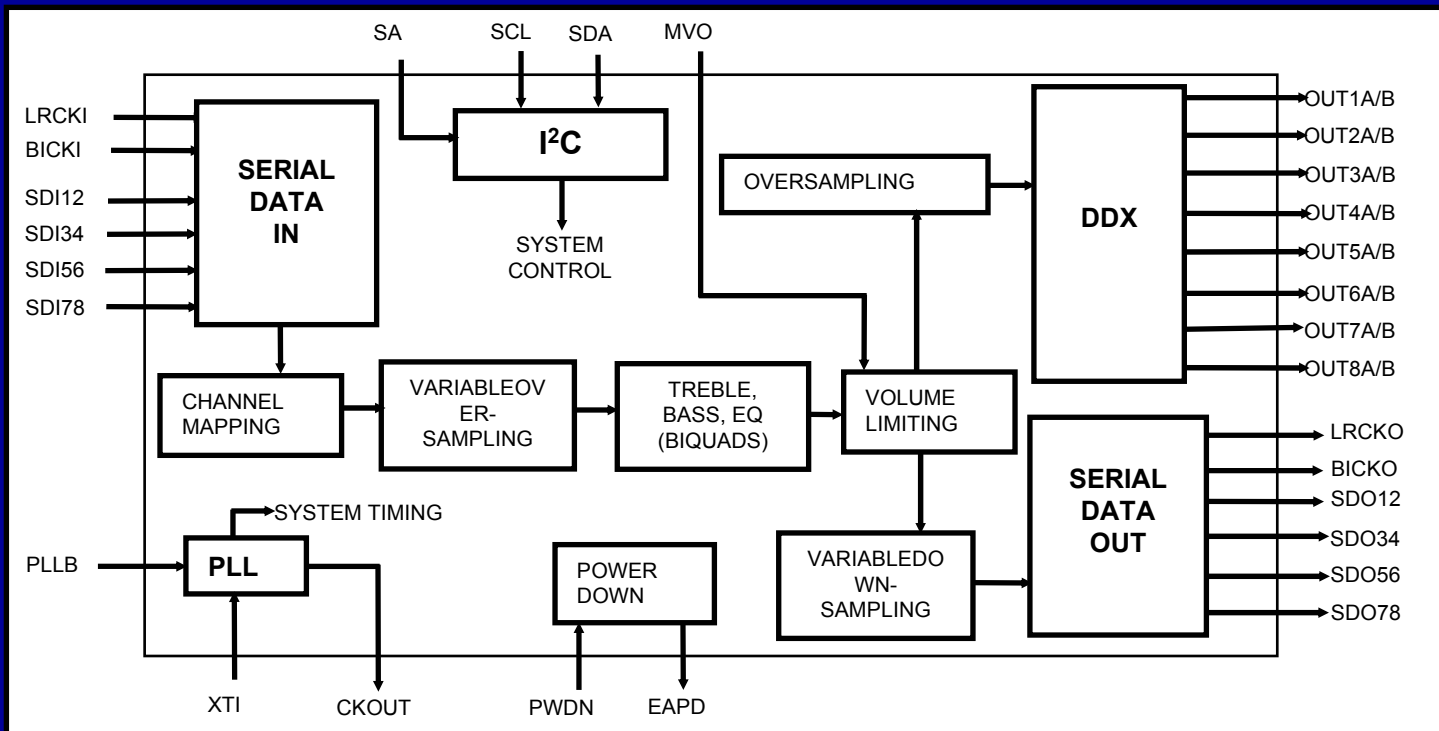

- Serial(IIS) In and Out
- DDX Output

- I²C Control
- Synchronous Clock Input

DDX-8000 Processing Flow

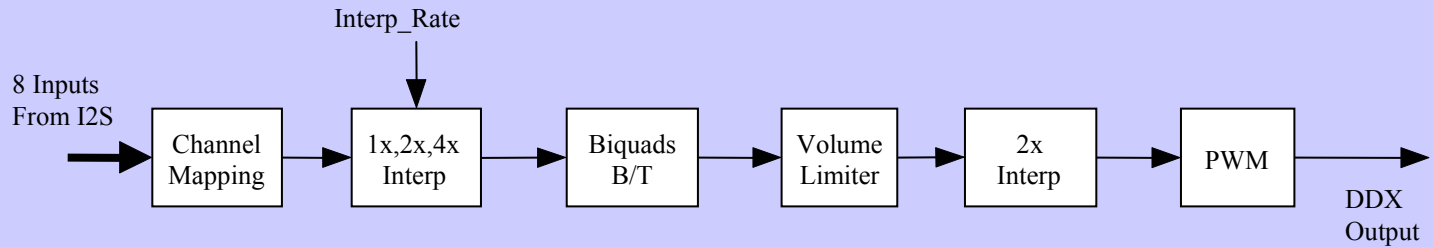

Channel Processing 1 to 5

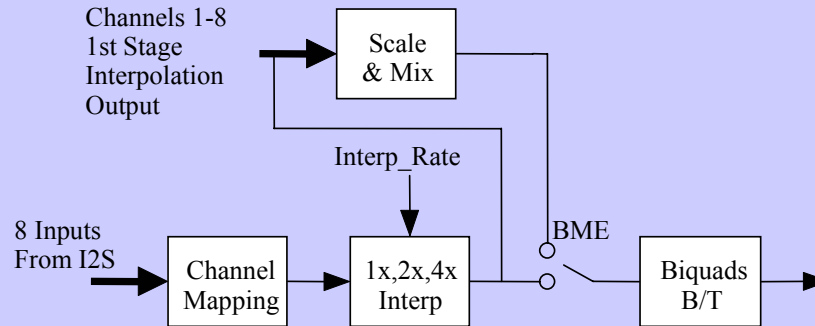

Channel 6 Scale/Mix

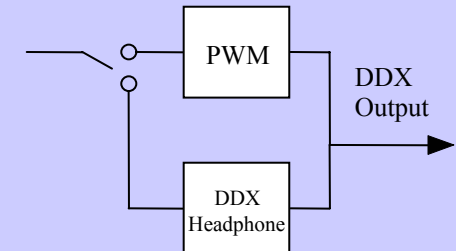

**Channel 7/8
Headphone Output**

DVD Receiver Audio Signal Flow

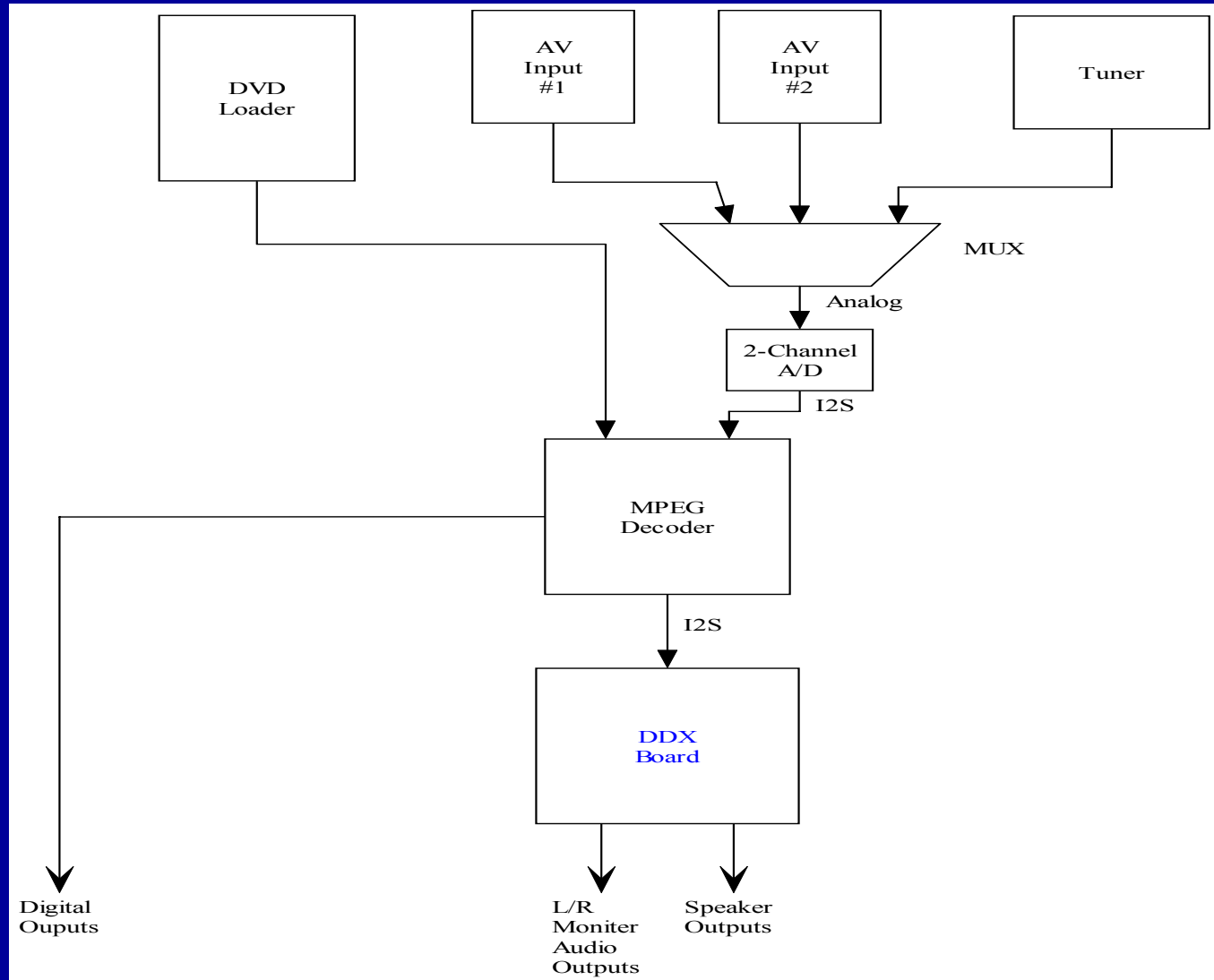

DDX-8000 DVD Application

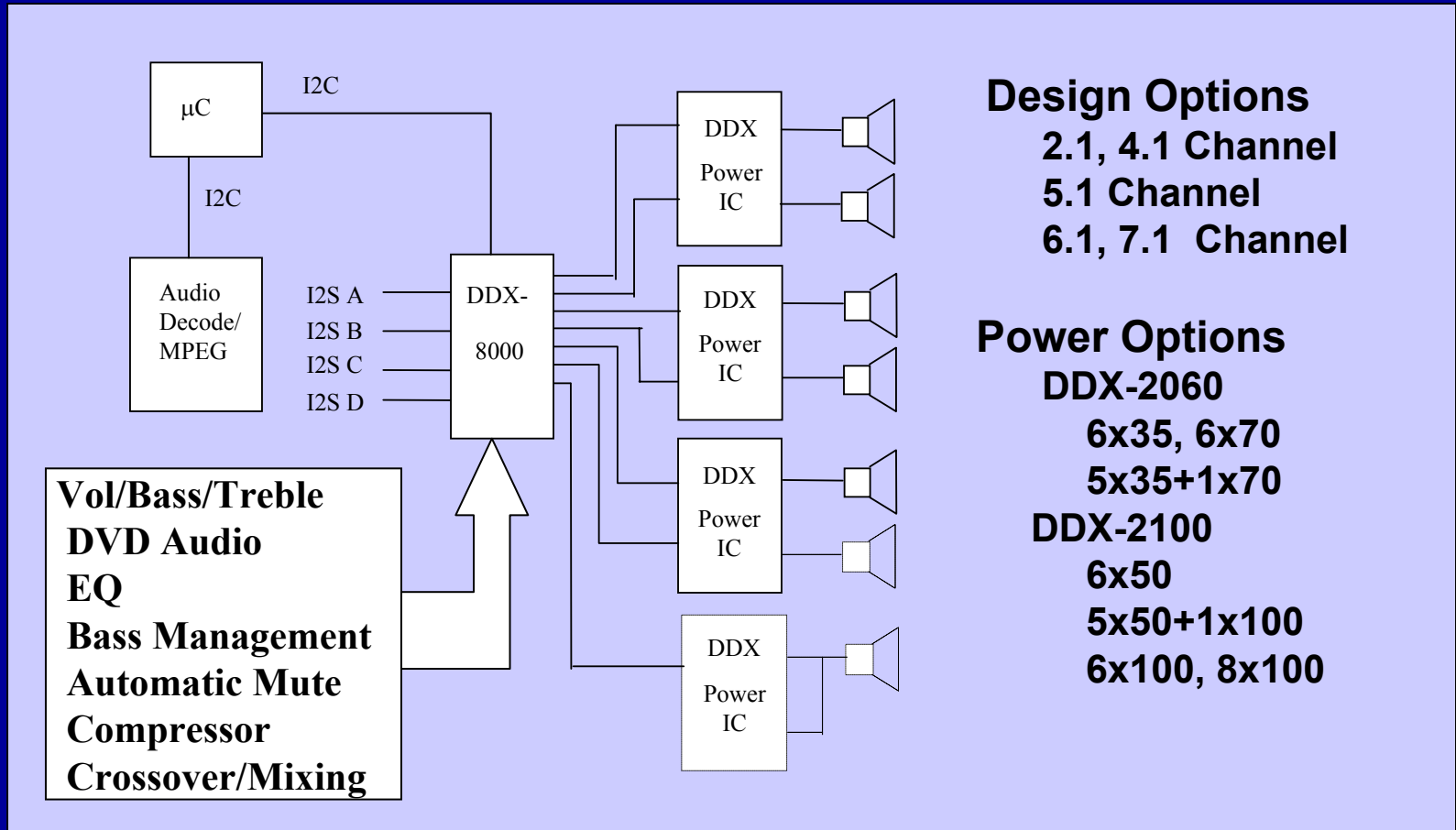

Design Options
 2.1, 4.1 Channel
 5.1 Channel
 6.1, 7.1 Channel

Power Options
DDX-2060
 6x35, 6x70
 5x35+1x70
DDX-2100
 6x50
 5x50+1x100
 6x100, 8x100

Analog Output From DDX8000

- Binary Output – Direct Analog
- Eliminates Need For D/A
- Use Channels 7+8 For Line-Out
- Or Use For Headphone Output
- Simple Passive or Active Circuit

Bass Management

MPEG	Dolby B.M.	DTS B.M.
Zoran Vadis	NO	NO
ESS 60x8	Fixed	NO

Solution	Bass Management
Apogee DDX8000	YES
TI TAS5026/5036	NO
Spaceon DPPC2006	NO
Philips All Products	NO
Tripath All Products	NO

A system in which there is NO/improper Bass Management will not pass Certification and will not reproduce bass.



AM Mode

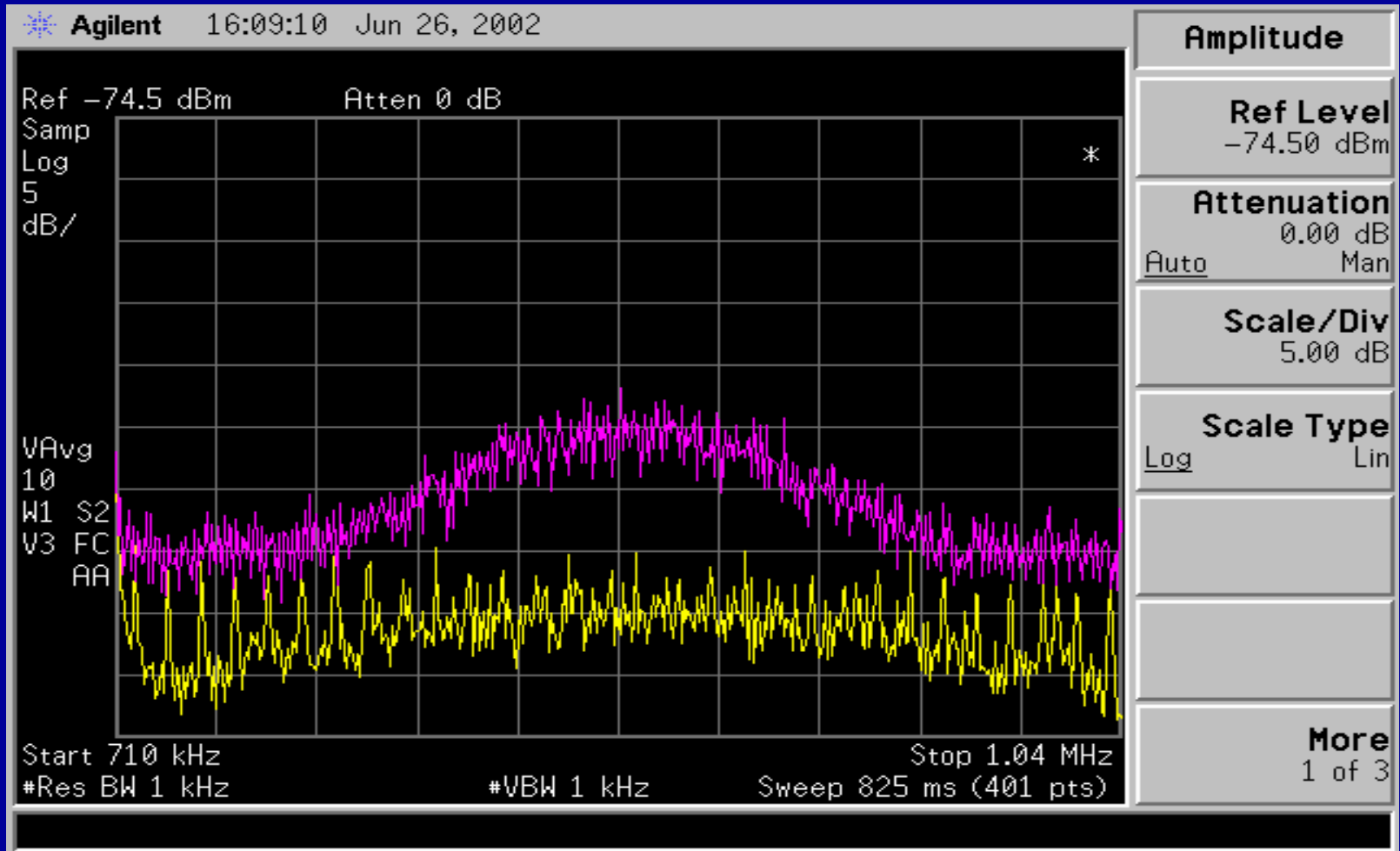

Common Mode Output Spectrum 710 – 1040 kHz
 AM Mode Provides 12-15 dB Improvement in
 AM Band Noise

EQ Functionality

- Speaker Correction
- Crossover
- Preset EQ(Rock, Jazz, Pop...)
- Graphic EQ
- Bass Boost
- Loudness



Apogee EQ Filter Software

DDX8000ControlPanel

File Device Window Help

Control Registers Filter Editor

Channel Filter Coefficient Link

Preset Filters: Rock Jazz Acoustic Classical Flat

Freq (Hz)	Gain (dB)
32	0
63	0
125	0
200	+5
250	0
500	0
1k	0
2k	0
4k	0
8k	+5
16k	0

Filter	Gain	Freq	Q	Type	Stable
Filter 1	+5	200	1.414	Parametric	Yes
Filter 2	+2	4000	1.414	Parametric	Yes
Filter 3	+5	8000	1.414	Parametric	Yes
Filter 4	0	0	0	Off	
Filter 5	0	0	0	Off	

Note: To set a parameter to a precise value, right click on the related Auto-PreScale Scaling: -5.45 dB



Compressor/Limiter Functionality

- No Clipping
- Psycho Acoustically Louder
- Set Amount of Clipping (Limit 10%)
- Dual Limiter for Different Sub Settings
- Nighttime Listening Mode
- AGC for TV Commercials/Channels
- Variable Attack and Release
- Ability to set Minimum Dynamic Range

Apogee DDX8000 Evaluation Platform

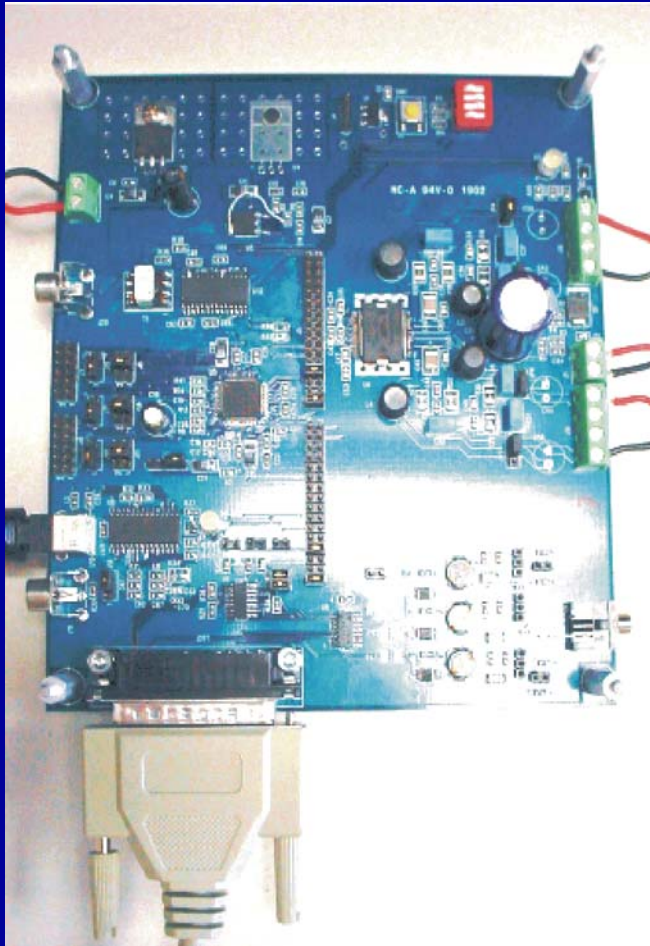

EB8000

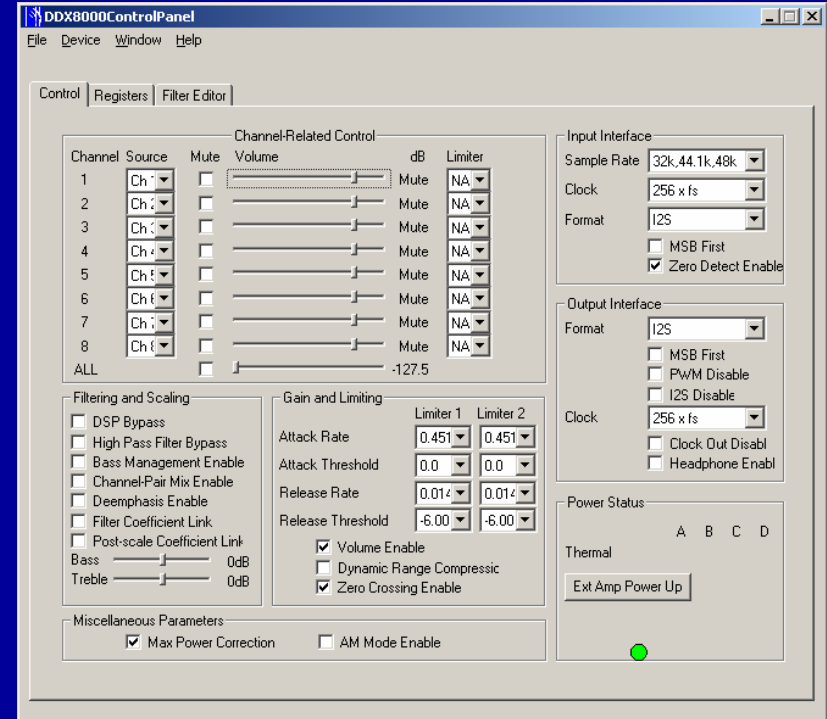

Control Software

Application Notes

- I2C Settings
- Layout Guidelines
- Component Selection
- Heat Dissipation
- Schematics
- EMI
- Testing
- Power Supply Issues



Power Circuit PCB Design is Critical

- Don't re-invent the wheel.
- Apogee has developed reference designs for most applications.
- Copy our designs! It's less work for everyone.

Apogee Review

It is important for Apogee to review designs once schematic and layout has been completed.

We can find problems and speed up development of the project.



Layout Critical SMD Caps

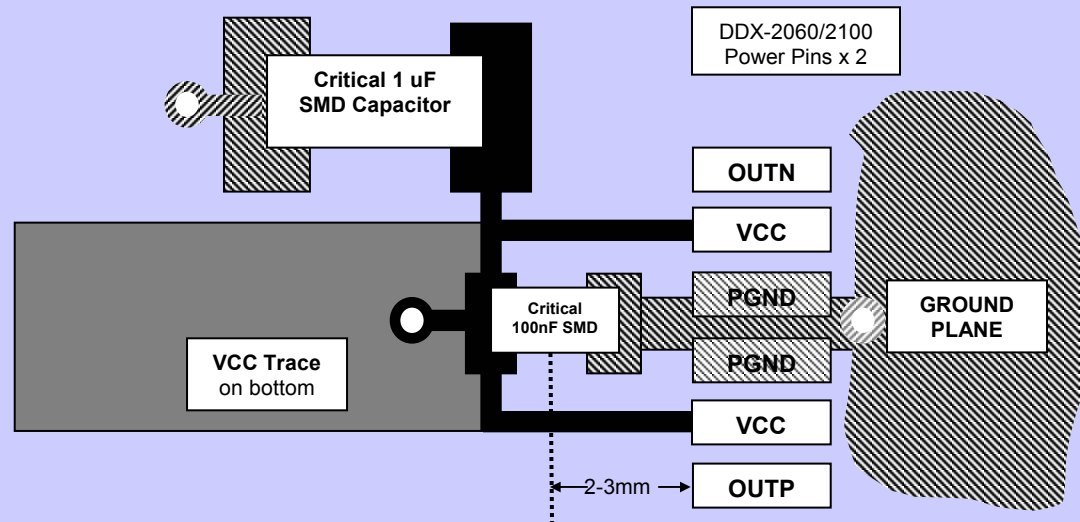

Critical bypass capacitors suppress spikes on VCC pins protecting from potentially damaging voltage transients. Follow this design for best performance and reliability. The 100nF capacitors must be SMD ceramic, X7R, 50V. The 1uF capacitors must be SMD tantalum or ceramic. Do not use radial aluminum caps for this purpose; they won't work! Ground plane is used on both component and solder sides of the PCB, except underneath the mounting surface of the DDX-2100.

Layout Output Filter Inductors

Output Inductors **MUST** be separated for best performance

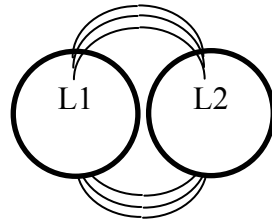

Too Close! Magnetic Coupling causes crosstalk and distortion.

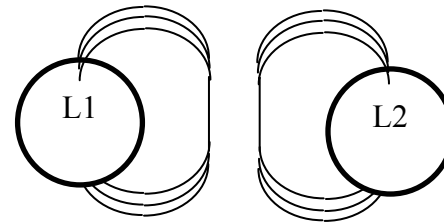

Adequate spacing (>8 mm) keeps magnetic flux lines from coupling into adjacent inductors.

Inductors required to be close should be Shielded type.

Use a SINGLE Ground Plane

- DDX is All-Digital.
- No Analog Ground Plane needed.
- Fill unused board area with ground.
- Use many vias to connect top and bottom planes especially along power supply routing.
- Make sure high current paths are SHORT and DIRECT.

DDX2060 Soldering

- DDX2060 Must Have Plated Vias Beneath the chip.
- No Top Soldermask underneath DDX2060 Heatslug
- Solder Must Be Used Through Vias
- Heat Flow:
Metal Slug->Solder->Ground Plane->
Heatsink

DDX-2060 PC Board Mounting

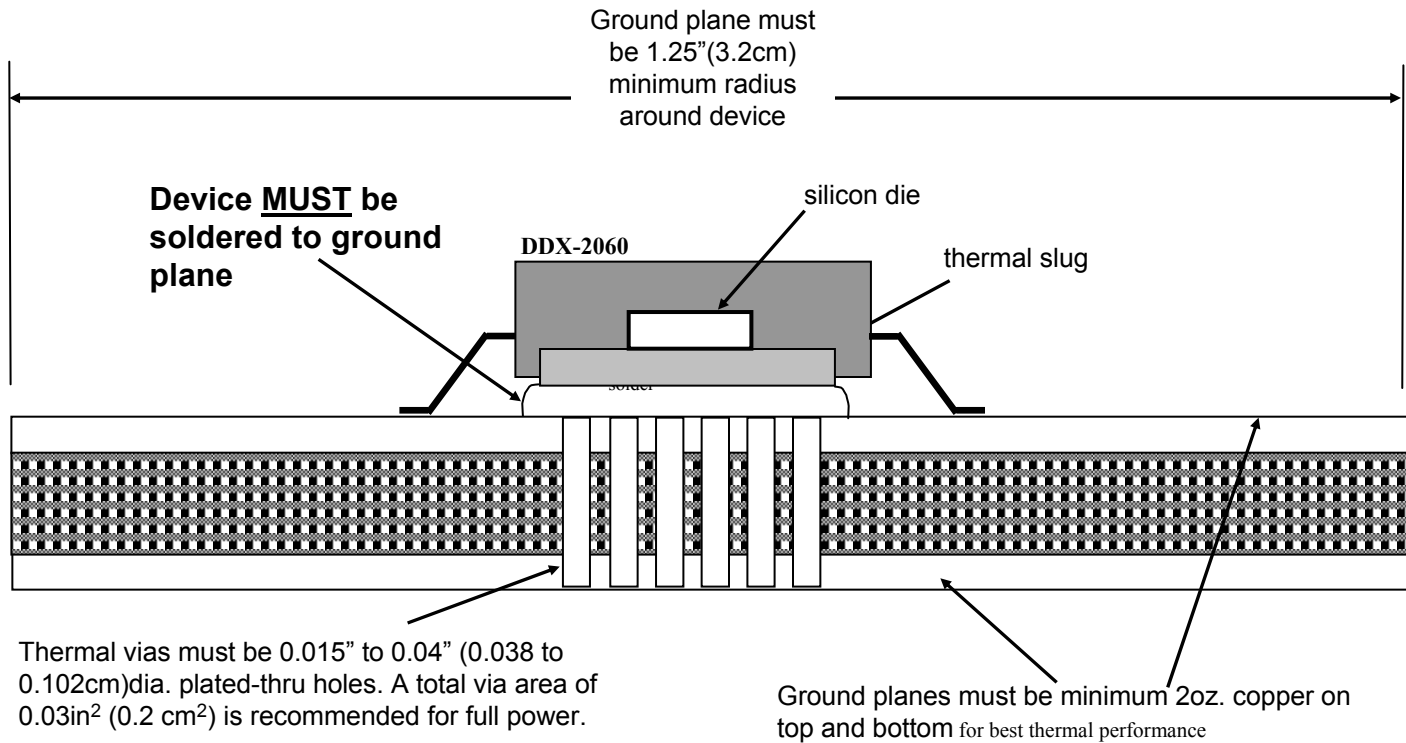

DDX-2060 Heat Sinking

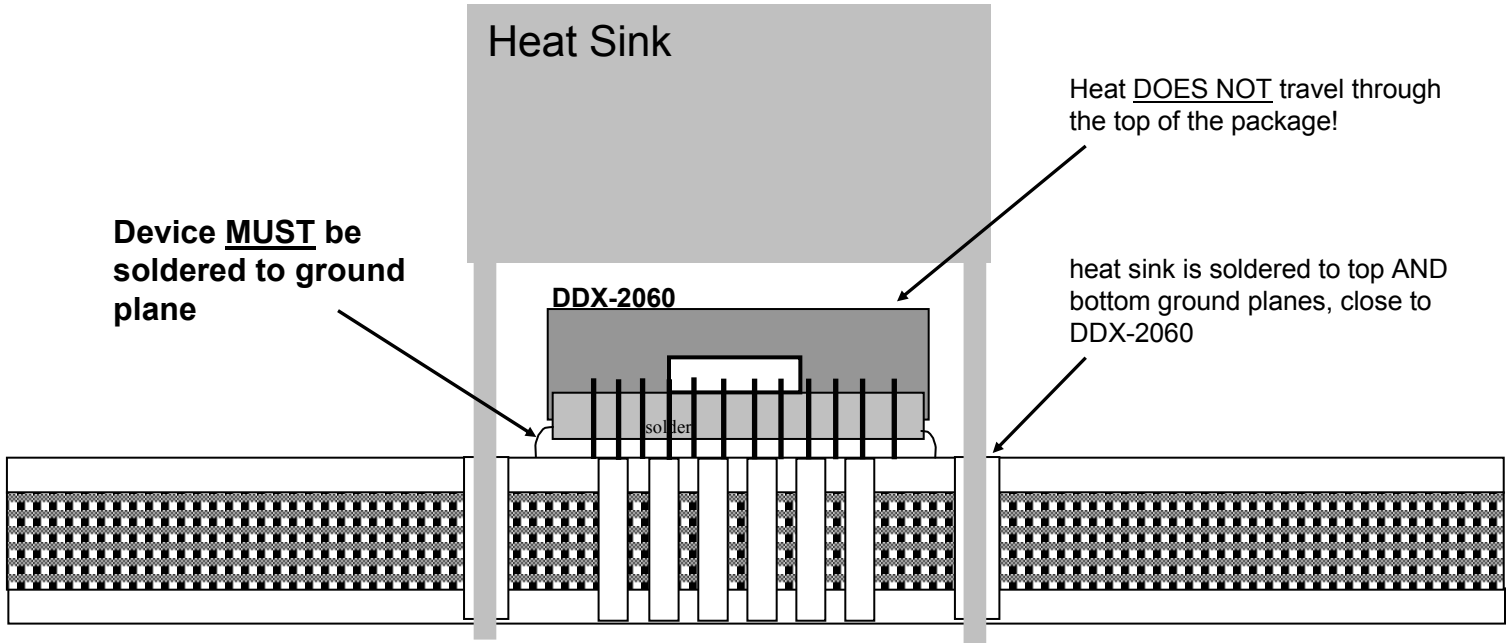

If there is not enough unbroken copper area available around the DDX-2060, a heat sink can be added to remove the heat from the package. Since the heat comes out through the metal slug on the bottom of the device and NOT through the top, both the device and the heat sink must be soldered to the pc board. The vias for the heat sink must be located close to the chip for acceptable thermal transfer.

DDX-2100 PC Board Mounting

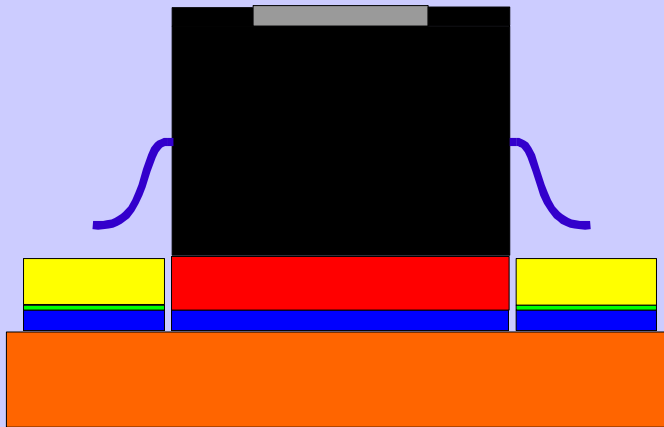

BLUE = COMPONENT LAYER COPPER 69 μM THICKNESS
 GREEN = COPPER TIN PLATING 17 μM TYPICAL THICKNESS
 YELLOW = SOLDER PASTE 150 μM TYPICAL THICKNESS
 RED = SOLDERMASK LAYER 50 μM to 180 μM THICKNESS

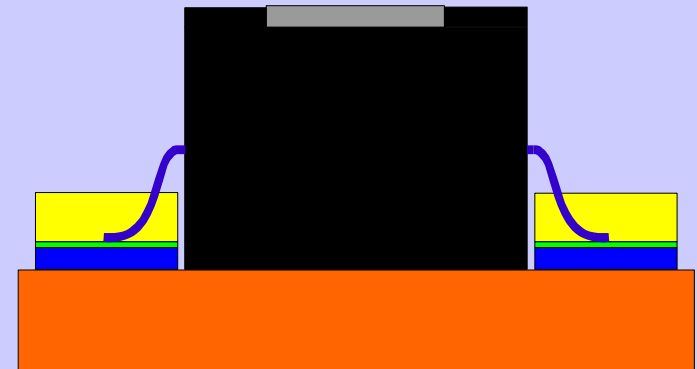

BLUE = COMPONENT LAYER COPPER 69 μM THICKNESS
 GREEN = COPPER TIN PLATING 17 μM TYPICAL THICKNESS
 YELLOW = SOLDER PASTE 150 μM TYPICAL THICKNESS

- The height of the Copper and Solder Mask under the DDX-2100 position the device too high to solder properly.
- Remove Copper and Solder Mask underneath the mounting surface for proper soldering.

DDX-2100 Heat Sinking

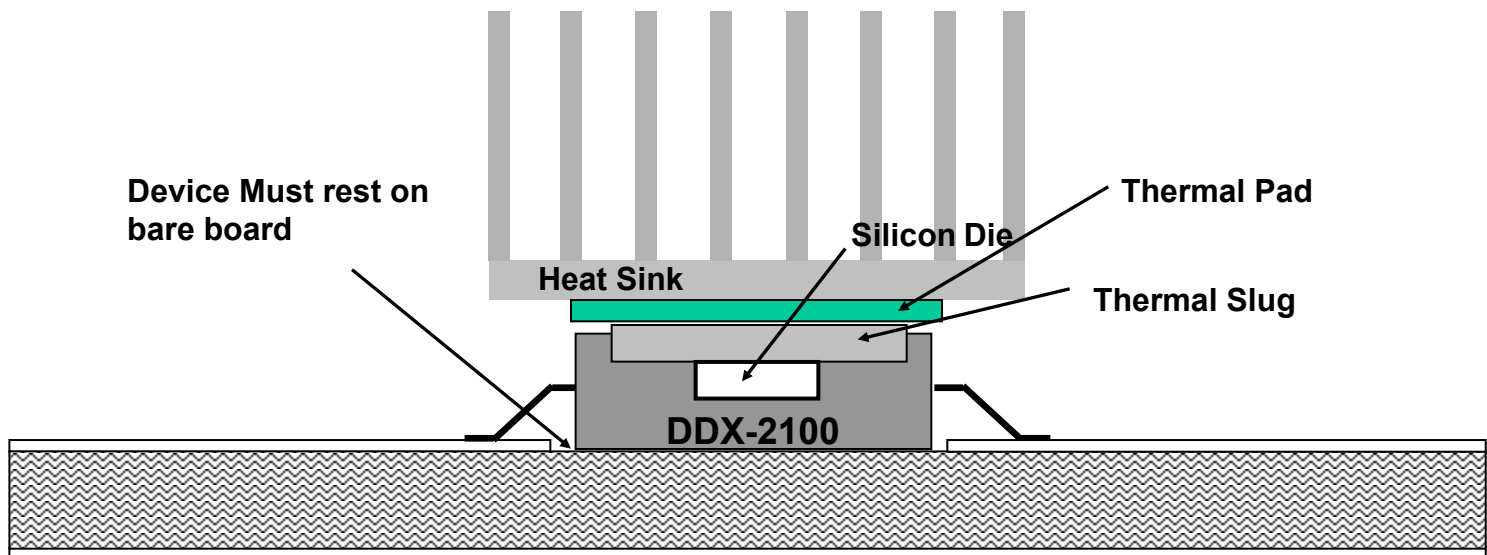

- Estimate DDX-2100 losses @ 20% of the Output Power (84% efficiency) when $T_j=150^{\circ}\text{C}$.
- This means that for CONTINUOUS OPERATION (FTC or DIN) you will need at least:
 - 3.3 sq cm per watt of output power at 25°C ambient temperature.
 - 6.6 sq cm per watt of output power at 50°C ambient temperature.
- This assumes thermal resistances of $2.5^{\circ}\text{C}/\text{W}$ junction-to-case and $0.5^{\circ}\text{C}/\text{W}$ for the thermal pad.
- For Normal Audio Power operation (non FTC or DIN), a smaller heatsink may be acceptable.

How to Avoid Pop Noise #1

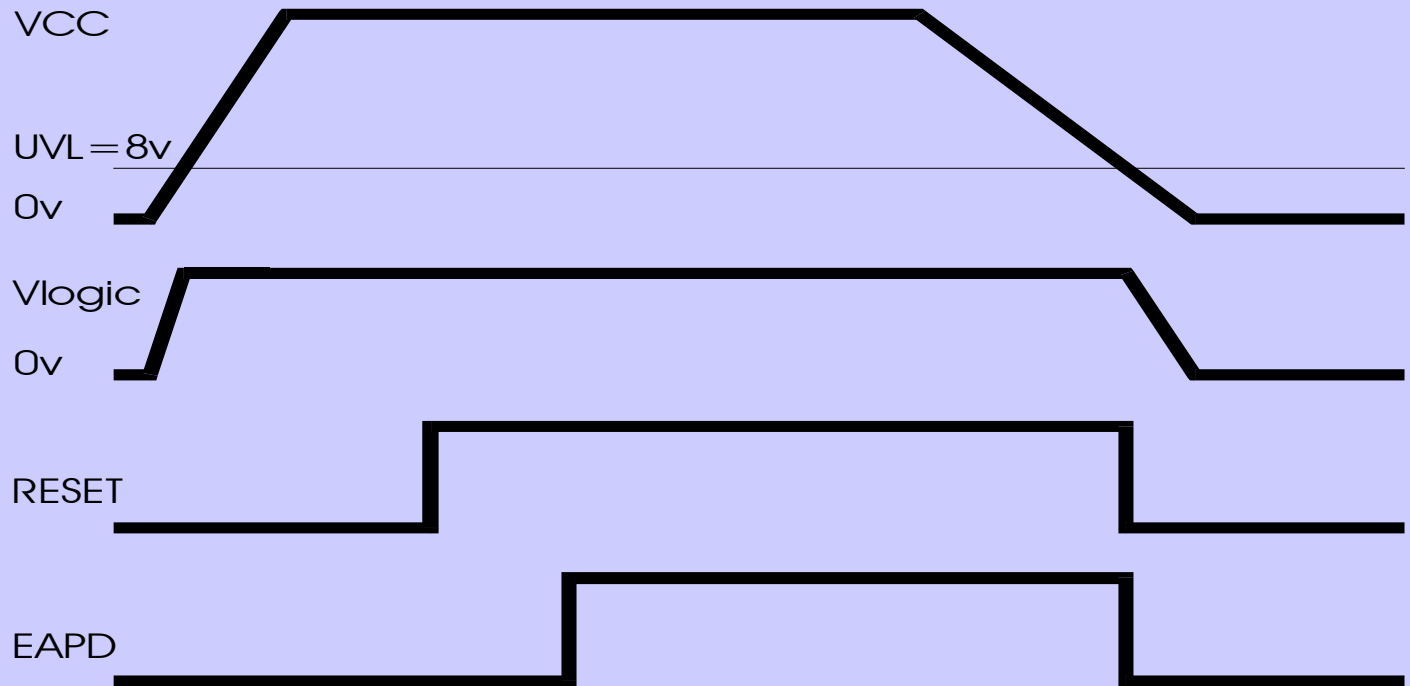

The Logic Power supply is stable prior to VCC reaching the Under-voltage lockout threshold and remains stable when power is removed until VCC decays below the UVL. When the logic supply is regulated from VCC, this sequence is automatically achieved.

How To Avoid Pop Noise #2

Use Reset Supervisor IC

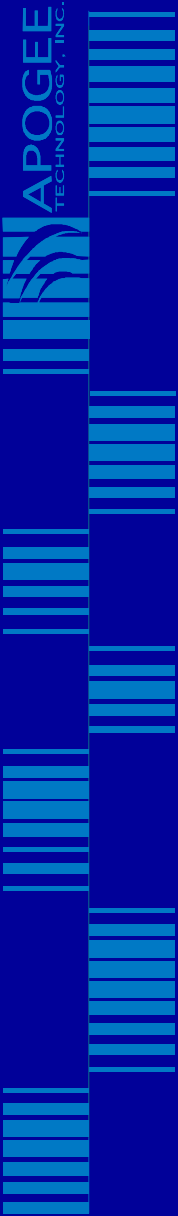

PWM R's DEGRADE PERFORMANCE

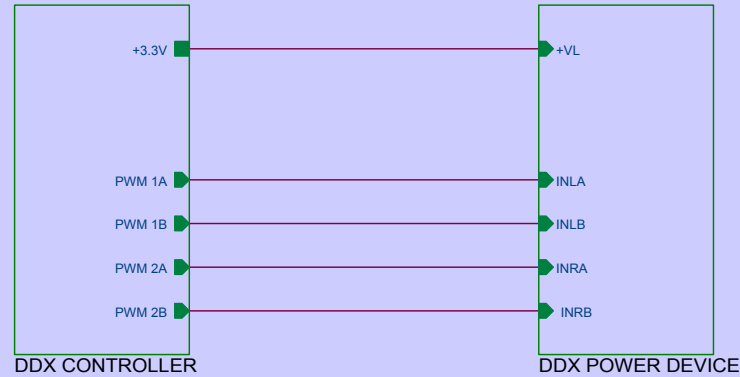

DO.

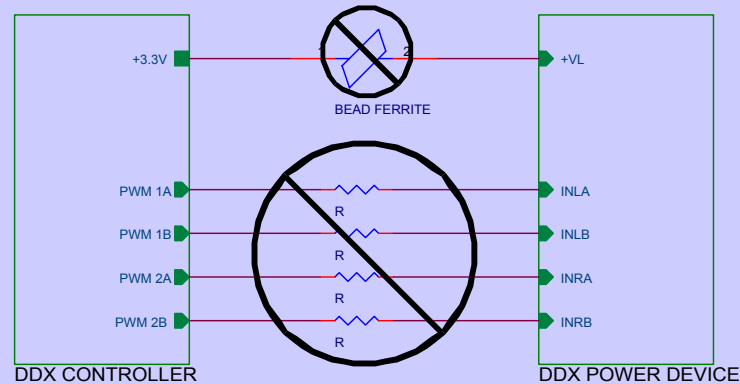

DON'T.

PWM series resistors and Ferrite bead on VL will degrade SNR at least >6dB!

DDX-2060 Power Output - Stereo

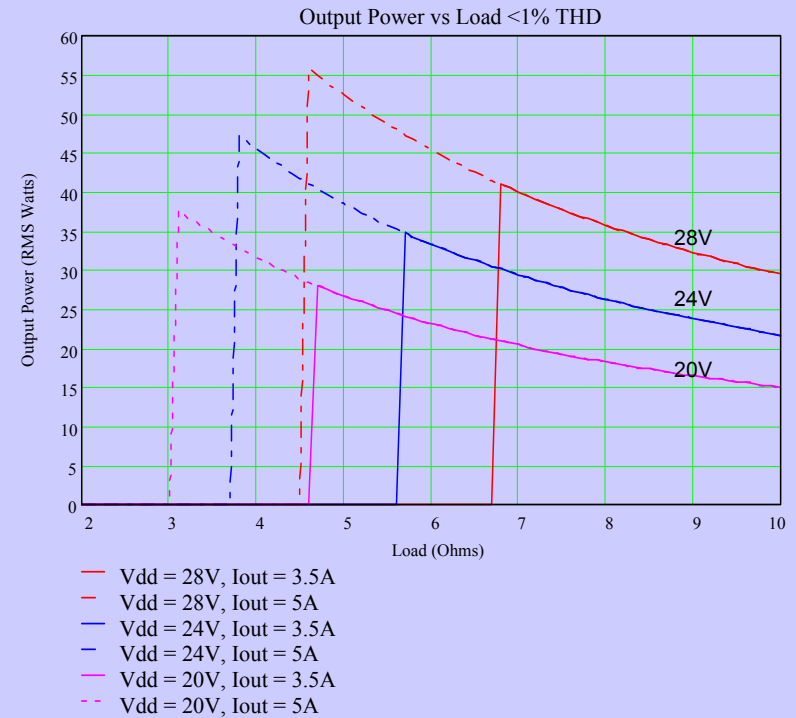
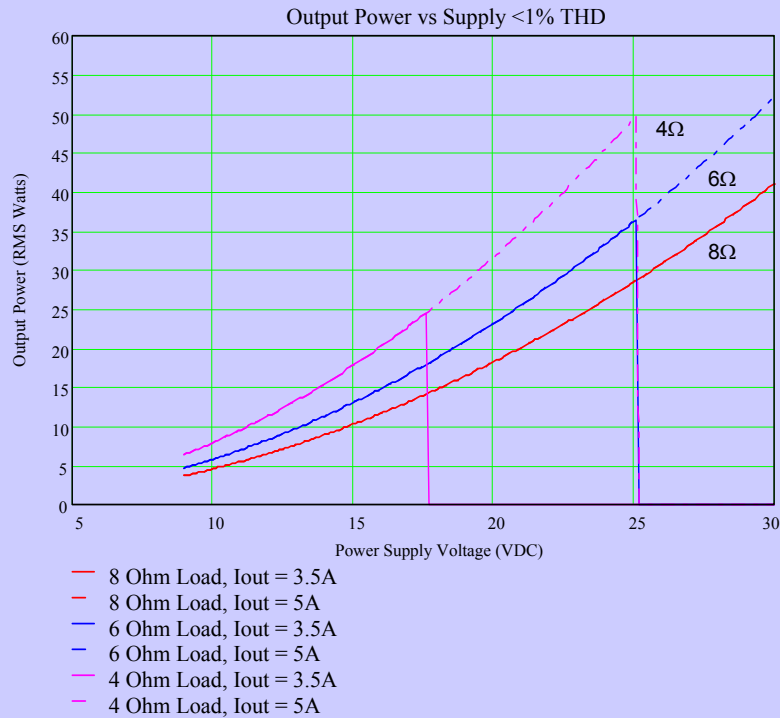

*Output Power of 2x35 Watts at 28V, 8 Ω (Minimum)
Power Reaches over 2x50 Watts (30V, Typical) at 10% THD*

DDX-2060 Power Output - Mono

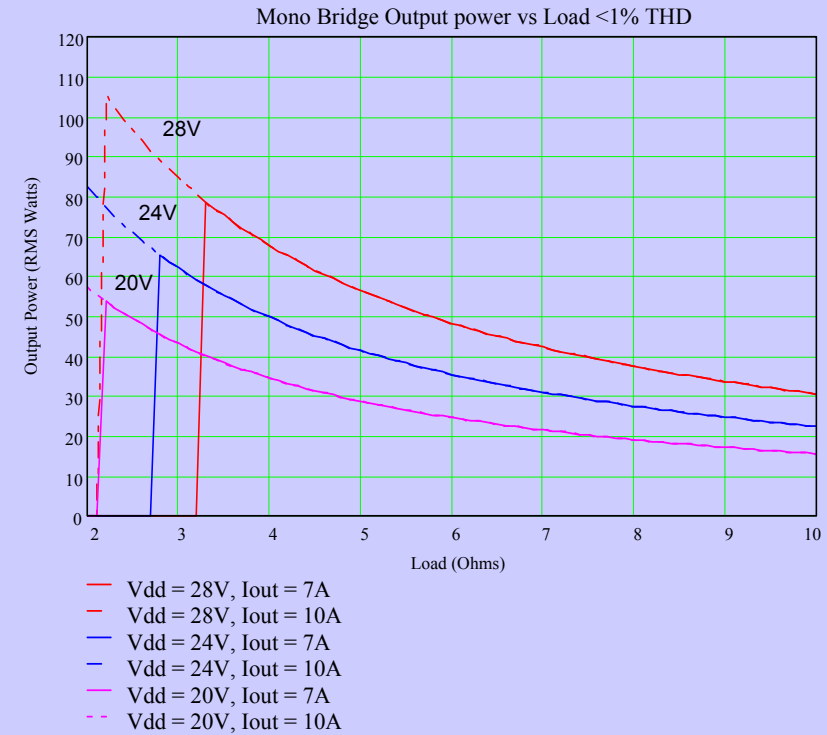
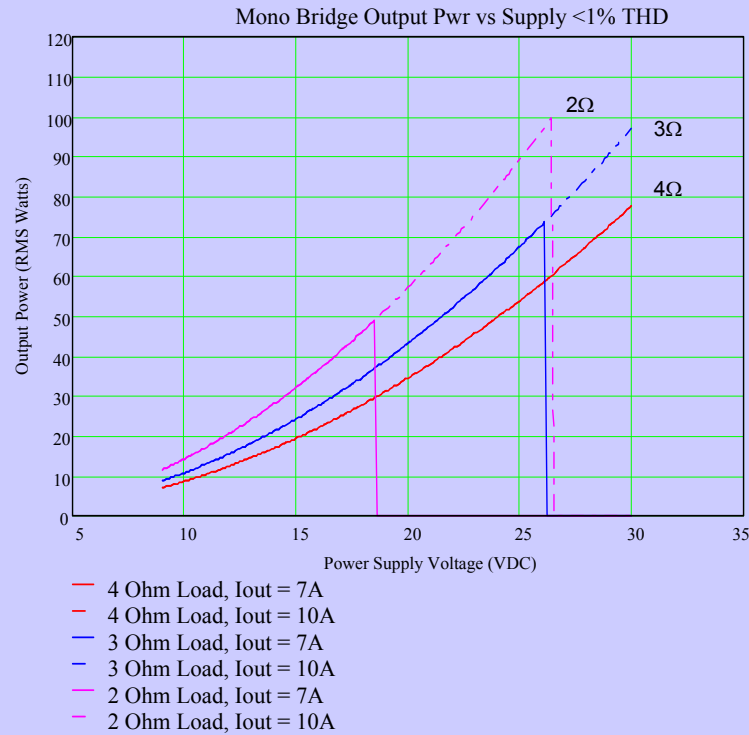

*Mono Mode Parallels Outputs to Double Current To Load
Up to 100 Watts Output and 70 Watts (Min.) into 4 Ω*

DDX-2100 Power Output - Stereo

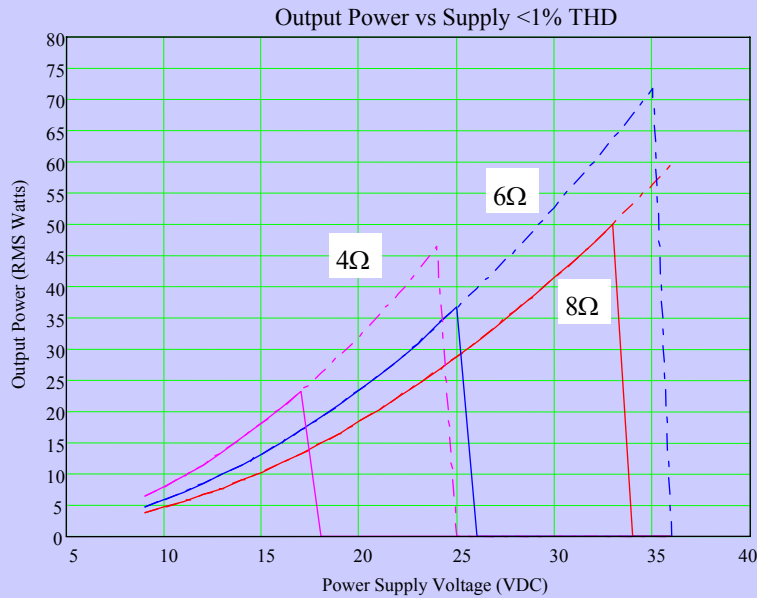

- 8 Ohm Load, Iout = 3.5A
- 8 Ohm Load, Iout = 5A
- 6 Ohm Load, Iout = 3.5A
- 6 Ohm Load, Iout = 5A
- 4 Ohm Load, Iout = 3.5A
- 4 Ohm Load, Iout = 5A

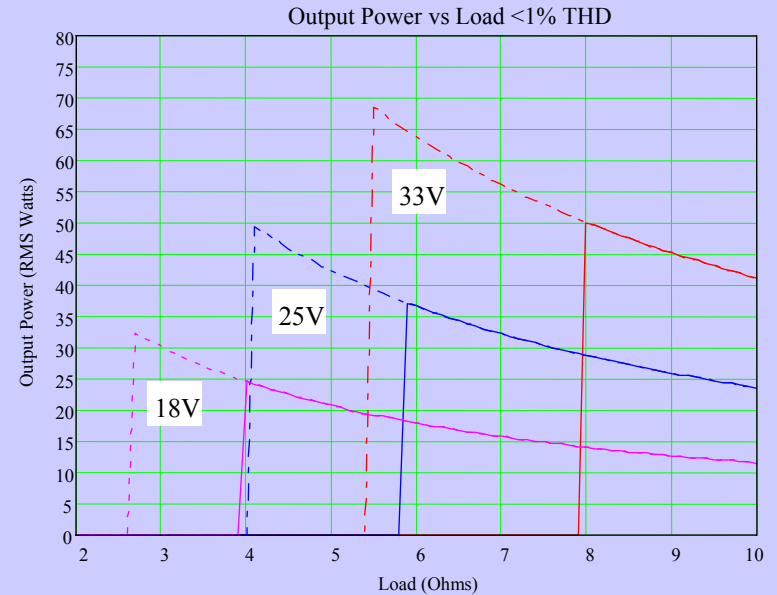

- Vdd = 33V, Iout = 3.5A
- Vdd = 33V, Iout = 5A
- Vdd = 25V, Iout = 3.5A
- Vdd = 25V, Iout = 5A
- Vdd = 18V, Iout = 3.5A
- Vdd = 18V, Iout = 5A

*Output Power of 2x50 Watts at 33V, 8 Ω (Minimum)
Power Reaches over 2x75 Watts (36V, Typical) at 10% THD*

DDX-2100 Power Output - Mono

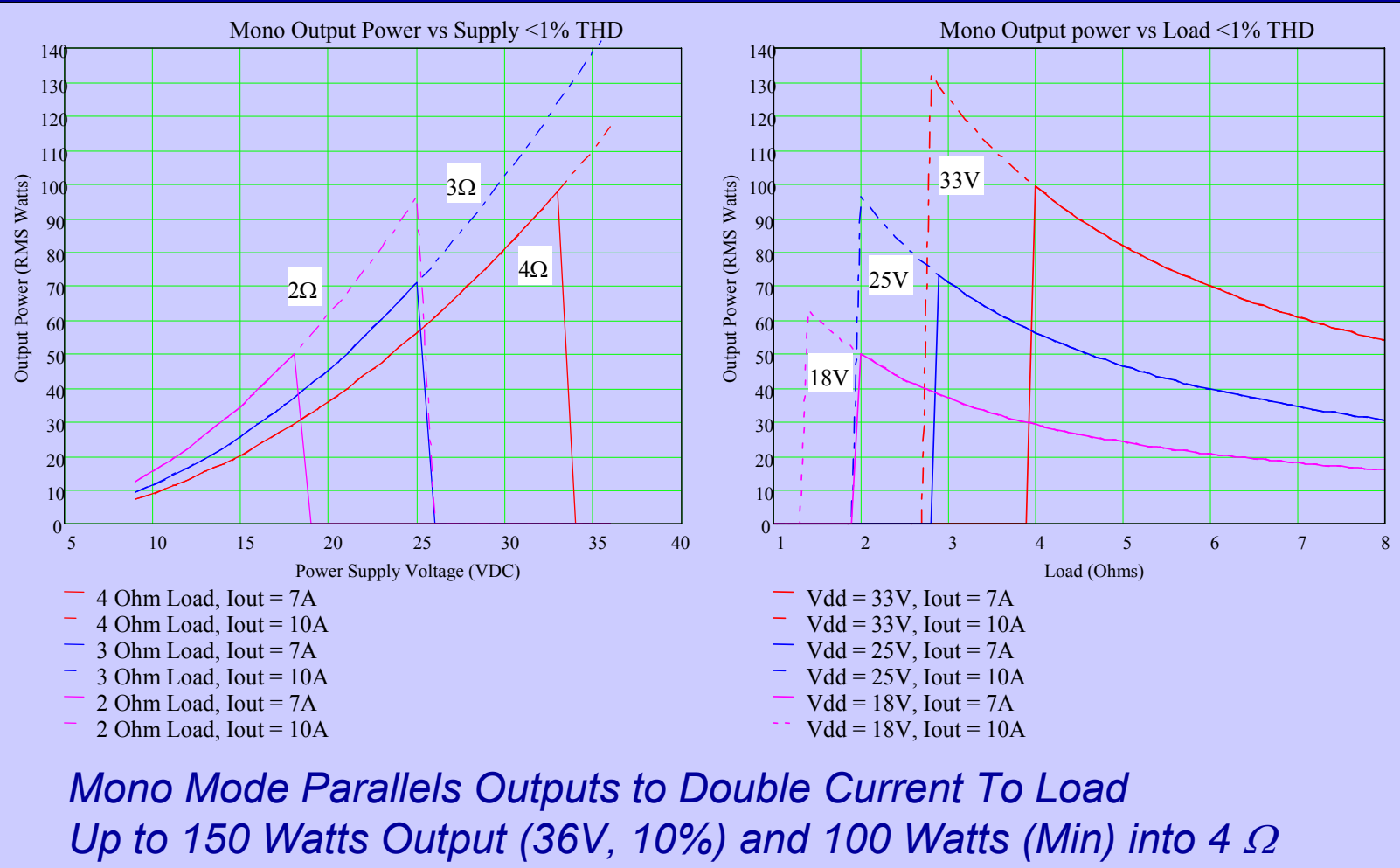

Real Power

Be Careful of Competition
Quoting 10% THD Power #'s

10% THD is ~30% Greater
Than Apogee 1% #'s

If customer spec is for 10% THD
Than make sure quoted #'s are higher.

Layout Considerations 1

- Power Supply Decoupling
 - Minimize inductance loop area for SMD ceramic bypass capacitors connected to pins VCC1,2, VSIG, VREG2, VREG1, and VL on the DDX-2060/2100.



Layout Considerations 2

- Power Routing
 - Provide star configuration power routing to each DDX-2060/2100 circuit or daisy chain between bulk electrolytic bypass capacitors.
 - Minimize inductance loop area between each DDX-2060/2100 and its respective bulk bypass capacitor.
 - Do not route DDX-2060/2100 power connections under output filter inductors, to prevent noise coupling to the speaker outputs.

Layout Considerations 3

- Ground Plane

- PWM logic signals and DDX-2060/2100 H-Bridge outputs should be routed over a continuous ground plane.
- Only one contiguous ground should be used for each amplifier circuit including the DDX processor and power device(s).
- Ground plane areas are also used as thermal dissipating elements on the PCB for the DDX-2060.

Layout Considerations 4

- Snubber Circuits
 - Locate RC snubber circuits as close as practical between the outputs of the DDX-2060 or DDX-2100



Layout Considerations 5

- Output Routing
 - **Inductor placement -**
 - Maintain a minimum physical separation of 1 cm, particularly between inductors of different channels.
 - Use shielded inductors when physical separation is not practical.
 - Place inductors as close as possible to the DDX-2060/2100 bridged outputs.
 - Minimize PCB trace length on OUTPx and OUTNx signals.
 - **Output traces -**
 - Balance the impedance of PCB traces in the output circuit so as to maintain source matching.
 - Match PCB traces on each output circuit to within 10 milliohms.

Power Output Configurations For 5.1

- 5x12W – 8 Ohms + 1x50W – 6 Ohms (2 DDX2060)
- 5x20W – 4 Ohms + 1x50W – 6 Ohms (2 DDX2060)
- 6x35W – 8 or 6 Ohms (3 DDX2060)
- 5x35W – 8 or 6 Ohms + 1x70W – 4 Ohms (4 DDX2060)
- 6x55W – 8 or 6 Ohms (3 DDX2100)
- 5x55W – 8 or 6 Ohms + 1x100W – 4 Ohms (4 DDX2100)
- 6x70W – 4 Ohms (6 DDX2060)
- 6x75W – 6 Ohms (6 DDX2100)
- 6x100W – 4 Ohms (6 DDX2100)

All Numbers are at <1% THD, <10% THD Numbers
Are 30% greater.

Power Output Configurations For 2.1

- 2x10W – 8 Ohms + 1x35W – 8 Ohms(1 DDX2060)
- 2x15W – 4 Ohms + 1x35W – 8 Ohms(1 DDX2060)
- 2x35W – 8 or 6 Ohms + 1x70W – 4 Ohms(2 DDX2060)
- 2x50W – 8 or 6 Ohms + 1x100W – 4 Ohms(2 DDX2100)

Power Output Configurations For 2.2

- 2x35W – 8 Ohms + 2x70W – 4 Ohms(3 DDX2060)
- 2x50W – 8 Ohms + 2x100W – 4 Ohms(3 DDX2100)

All Numbers are at <1%THD, <10% THD Numbers
Are 30% greater.

Customer Support

- Apogee Engineering Support
- Apogee Reference Boards
 - DDX-8000 5x15 + 1x30
 - DDX-4100 6x35W
 - DDX-8000 6x50W
 - DDX-8000 6x100W
- Apogee Design Kits
 - Reference Schematics
 - Gerber Files
 - BOM



Low Power Reference Board

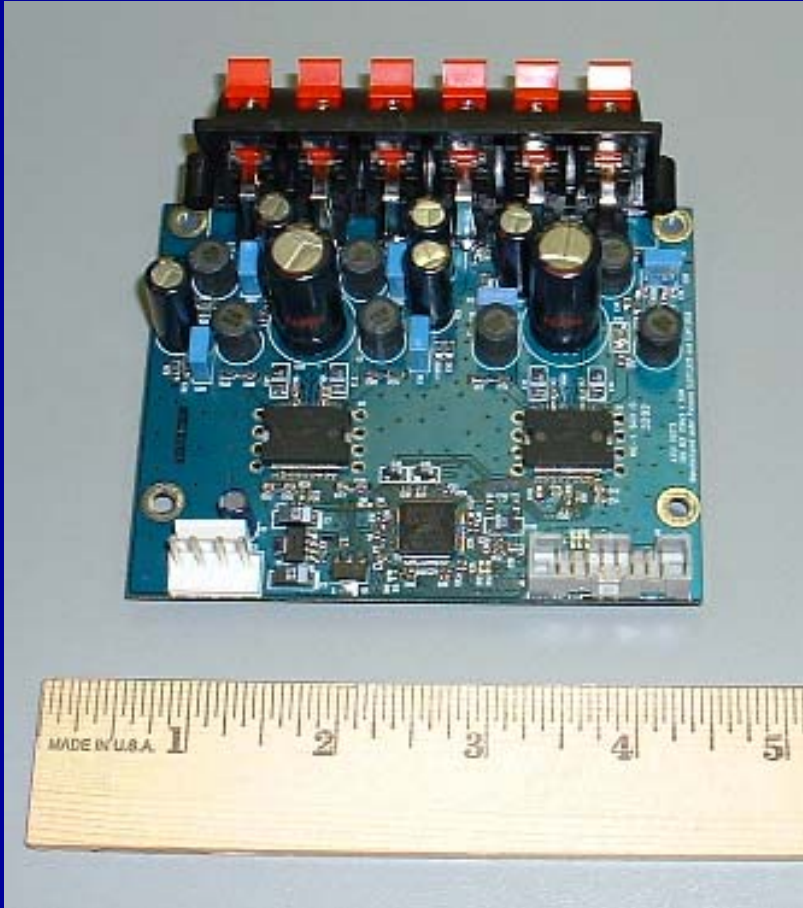

Features

Interface and Control

- I²C Control
- 4x I²S Input

Power Output

- +9 to +30VDC
- 5x15W+1x50W 6 Ω

DDX 8000 Functions

- Volume/Bass/Treble
- Equalization
- Compressor/Limiter
- Automute
- Bass Management

6x35W Reference Board

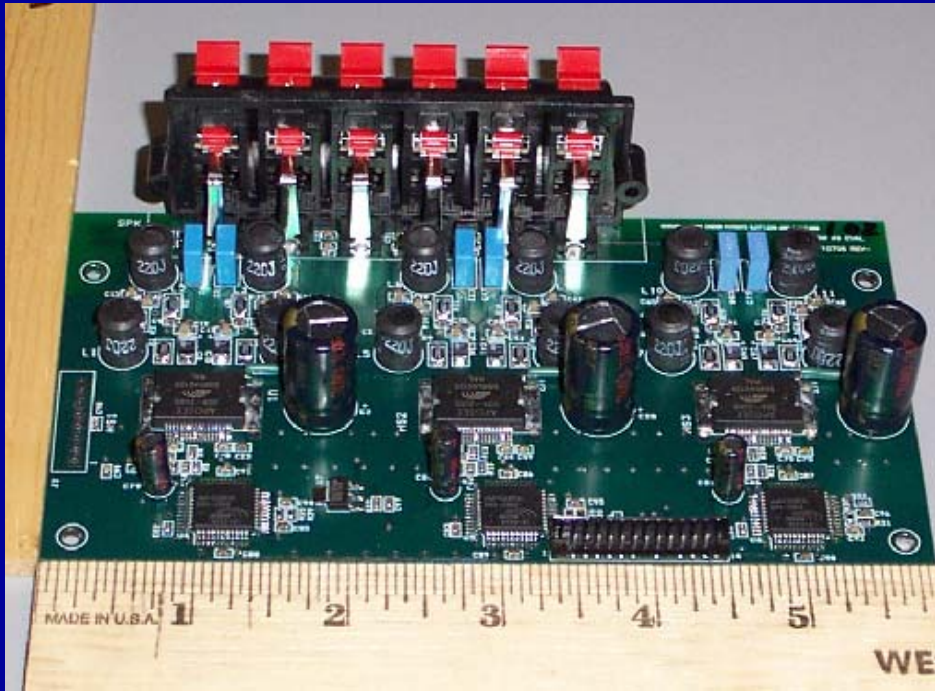

Features

Interface and Control

- I²C Control
- 4x I²S Input

Power Output

- +9 to +28VD
- 6x35W 8 Ω

DDX 8000 Functions

- Volume/Bass/Treble
- Equalization
- Compressor/Limiter
- Automute
- Bass Management

6x50W Reference Board

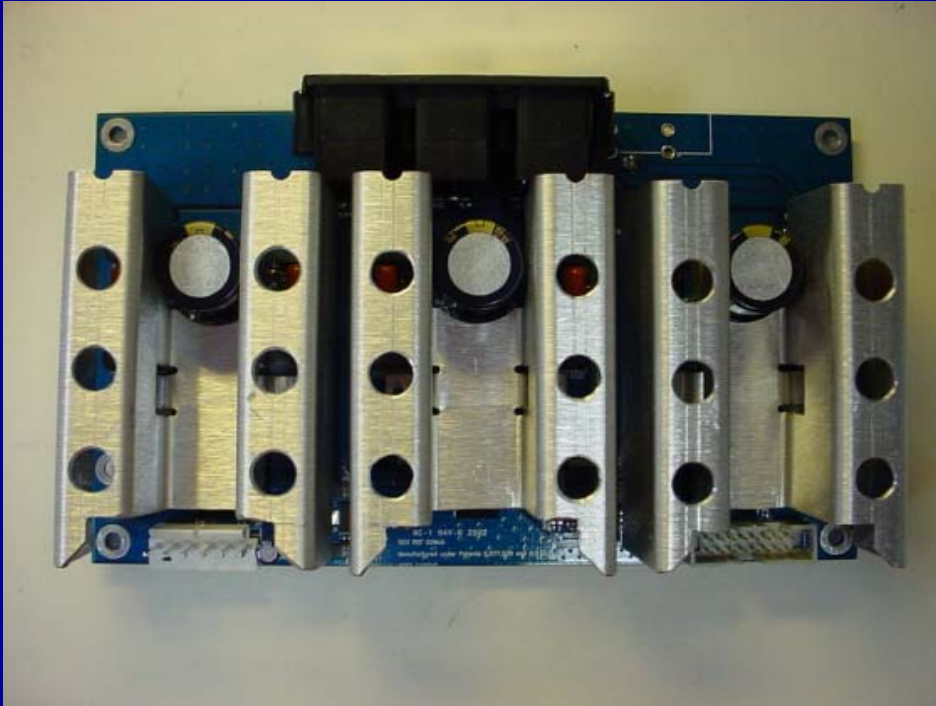

Features

Interface and Control

- I²C Control
- 4x I²S Input

Power Output

- +9 to 36V DC
- 6 x 60 Watts 8 Ω

DDX 8000 Functions

- Volume/Bass/Treble
- Equalization
- Compressor/Limiter
- Automute
- Bass Management

6x100W Reference Board

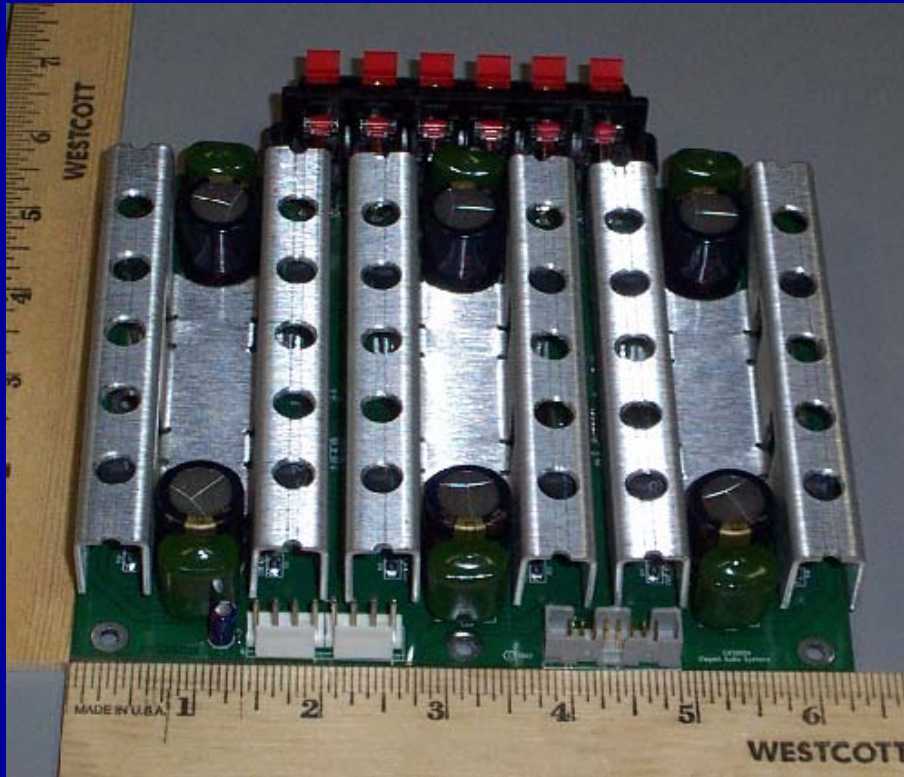

Features

Interface and Control

- I²C Control
- 4x I²S Input

Power Output

- +9 to +36VDC
- 6 x 100 Watts 4-6 Ω

DDX 8000 Functions

- Volume/Bass/Treble
- Equalization
- Compressor/Limiter
- Automute
- Bass Management

Apogee Apps Contacts

Asia

Webster Chu

wchu@apogeedx.com

US

Mike Determan

mdeterman@apogeedx.com

