



TS2950/TS2951 series

150mA Ultra Low Dropout Positive Voltage Regulator

TO-92



Pin assignment

TO-92

1. Output
2. Ground
3. Input

SOP-8



Pin assignment

SOP-8

1. Output
2. Sense
3. Shutdown
4. Ground
5. Error
6. Voltage tap
7. Feedback
8. Input

Input Voltage Range up to 30V

Output Current up to 150mA

Low Drop Out Voltage 0.4V

General Description

The TS2950/A & TS951/A are low power voltage regulators. These devices are excellent choice for use in battery-powered applications such as cordless telephone, radio control systems, and portable computers.

The TS2950/A & TS2951/A is features very low quiescent current (75uA Typ.) and very low drop output voltage (Typ. 40uV at light load and 380 mV at 100 mA). This includes a tight initial tolerance of 0.5% typ.(A version), extremely good load and line regulation 0.05% typ. and very low output temperature coefficient, making the TS2950/A & TS2951/A useful as a low-power voltage reference.

TS2951/A have other key additional feature of unregulated input voltage transient of -20V below ground (reverse battery).

The error flag output feature is used as power-on reset for warn of a low output voltage, due to following batteries on input. The logic-compatible shutdown input which enable the regulator to be switched on/off. The regulator output voltage may be pin-strapped for a 5.0, 3.3 & 3V of programmed from 1.24V to 29V with external pair of resistors. Using of as design, processing and testing techniques make TS2950/A & TS951/A superior over similar products.

The TS2950/A is offered in 3-pin TO-92 package, The TS2951/A is available in 8-pin plastic SOP-8 package.

Features

- ◇ Output voltage available in 5V, 3.3V & 3V
- ◇ Extremely low quiescent current
- ◇ Low dropout voltage
- ◇ Extremely tight load and line regulation
- ◇ Very low temperature coefficient
- ◇ Need only 1uF for stability
- ◇ Unregulated DC input can withstand -20V reverse battery and +60V positive transients
- ◇ Use as Regulator or Reference
- ◇ Stable with low-ESR output capacitors
- ◇ Current and thermal limiting
- ◇ Direct replacement for LP2950 & LP2951 sockets

TS2951 VERSIONS ONLY

- ◇ Error Flag warns of output dropout
- ◇ Logic-Controlled electronic shutdown
- ◇ Additional voltage tap
- ◇ Output voltage sense
- ◇ Output programmable from 1.24 to 29V

Application

- ◇ Battery powered systems
- ◇ Portable instrumentation
- ◇ Avionics
- ◇ Automotive Electronics
- ◇ SMPS Post-Regulator
- ◇ Voltage Reference
- ◇ Portable/Palm top / Notebook computers
- ◇ Portable consumer equipment
- ◇ Radio control system

Ordering Information

Part No.	Operating Temp.	Package
TS2950CT- xx	-40 ~ +85°C	TO-92
TS2951CS- xx		SOP-8
TS2950ACT- xx	-20 ~ +85°C	TO-92
TS2951ACS- xx		SOP-8

Note: Where xx denotes voltage option, available are 5.0V, 3.3V and 3V. Contact factory for additional voltage options.



Absolute Maximum Rating						
Input Supply Voltage		V _{in}	- 0.3 ~ +30	V		
Feedback Input Voltage		V _{feedback}	- 1.5 ~ +30	V		
Shutdown Input Voltage		V _{shutdown}	- 0.3 ~ +30	V		
Error Comparator Output Voltage		V _{error}	- 0.3 ~ +30	V		
Power Dissipation		P _d	Internally Limited	W		
Operating Junction Temperature Range	TS2950/2951	T _J	- 40 ~ +125	°C		
	TS2950A/2951A		- 20 ~ +125			
Storage Temperature Range		T _{STG}	-65 ~ +150	°C		
Lead Temperature (Soldering 5 second)		T _{STG}	260	°C		
TS2950/A & TS2951/A Electrical Characteristics						
(V _{in} =15V, T _a =25 °C unless otherwise specified.)						
Parameter	Test Conditions (note 2)		Min	Typ	Max	Unit
Output Voltage	T _j = 25 °C	TS2950/TS2951	0.990	5.0	1.010	V
		TS2950A/TS2951A	0.995	3.3	1.005	
	Full Operating temp	TS2950/TS2951	0.980	3.0	1.020	
		TS2950A/TS2951A	0.988		1.012	
	100uA ≤ I _L ≤ 100mA	TS2950/TS2951	0.975		1.025	
	T _j ≤ T _j (max)	TS2950A/TS2951A	0.985		1.015	
Output Voltage Temperature Coefficient	(Note 1)	TS2950/TS2951	--	50	150	ppm/
		TS2950A/TS2951A	--	20	100	°C
Line Regulation (Note 3)	6V ≤ V _{in} ≤ 30V (Note 4)		--	0.04	0.2	%
Load Regulation (Note 3)	100uA ≤ I _L ≤ 100mA		--	0.1	0.3	%
Dropout Voltage (Note 5)	I _L =100uA		--	50	80	mV
	I _L =100mA			380	450	mV
Ground Current	I _L =100uA		--	75	120	uA
	I _L =100mA			8	12	mA
Dropout Ground Current	V _{in} = 4.5V, I _L = 100uA		--	110	170	uA
Current Limit	V _{out} = 0		--	160	200	mA
Thermal Regulation			--	0.05	0.2	%W
Output Noise, 10Hz to 100KHz Bypass=0.01uF (pins 7 to 1 TS2951/A)	C _L = 1uF		--	430	--	uV/ rms
	C _L = 200uF			160		
	C _L = 3.3uF			100		
8-Pin TS2951/A Versions only						
Reference Voltage	TS2951		1.21	1.235	1.27	V
	TS2951A		1.22		1.26	
Reference Voltage	(Note6)	TS2951	1.185		1.285	V
		TS2951A	1.19		1.27	



TS2951/A Electrical Characteristics (continues)

(Vin= 15V, Ta= 25 °C unless otherwise specified.)

Parameter	Test Conditions (note 2)	Min	Typ	Max	Unit
Feedback Pin Bias Current		--	20	40	nA
Reference Voltage Temperature Coefficient	(Note 7)	--	20	--	ppm/ °C
Feedback Pin Bias Current Temperature Coefficient		--	0.1	--	nA/°C
Error Comparator					
Output Leakage Current	V _{OH} = 30V	--	0.01	1	uA
Output Low Voltage	Vin= 4.5V, I _{OL} = 400uA	--	150	250	mV
Upper Threshold Voltage	(Note 8)	40	60	--	mV
Power Threshold Voltage	(Note 8)	--	75	95	mV
Hysteresis	(Note 8)	--	15	--	mV
Shutdown Input					
Output Logic Voltage	Low (Regulator ON) High(Regulator OFF)	-- 2.0	1.3 1.3	0.7 --	V
Shut down Pin Current	V _s = 2.4V V _s = 30V	--	30 450	50 600	uA
Regulator Output Current in Shutdown	(Note 9)	--	3	10	uA

Note 1: Output voltage temperature coefficients defined as the worst case voltage change divided by the total temperature range.

Note 2: Unless otherwise specified all limits guaranteed for T_j= 25°C, Vin= 6V, I_L= 100uA and C_L= 100uF. Additional conditions for the 8-pin versions are feedback tied to 5V, 3.3V & 3V tap output Sense (Vout = 5V, 3.3V & 3V) and Vshutdown ≤ 0.8V.

Note 3: Regulation is measured at constant junction temperature, using pulse testing with a low duty cycle. Changes in output voltage due to heating effects are covered under the specification for thermal regulation.

Note 4: Line regulation for the TS2951 is tested at 85°C for I_L= 1mA. For I_L= 100uA and T_j= 125°C, line regulation is guaranteed by design to 0.2%.

Note 5: Dropout Voltage is defined as the input to output differential at which the output voltage drops 100mV below its nominal value measured at 1V differential at very low value of programmed output voltage, the minimum input supply voltage of 2V (2.3V over temperature) must be taken in to account.

Note 6: Vref ≤ Vout ≤ (Vin-1V), 2.3 ≤ Vin ≤ 30V, 100uA ≤ I_L ≤ 100mA, T_j ≤ T_j(max).

Note 7: reference voltage temperature coefficient is defined as the worst case voltage change divided by the total temperature range.

Note 8: Comparator thresholds are expressed in terms of a voltage differential at the feedback terminal below the nominal reference voltage measured at 6V input. To express these thresholds in terms of output voltage change, multiply by the error amplifier gain= Vout / Vref = (R1+R2) / R2. For example, at a programmed output voltage of 5V, the Error output is guaranteed to go low when the output drops by 95 mV X 5V / 1.250 = 384mV. Thresholds remain constant as a percent of Vout as Vout is varied with the dropout warning occurring at typically 5% below nominal, 7.5% guaranteed.

Application Hints

External Capacitors

For the stability of the TS2950/A & TS2951/A is requires a 1.0uF(0.22uF is recommended for 3.0V & 3.3V) or greater capacitor between output and ground. Oscillation could occur without this capacitor. The tantalum or aluminum electrolytic works fine; could use the film type work but are not cost efficient. For the operation of below -25 °C solid tantalum is recommended since the many aluminum type have electrolytes the freeze at about -30 °C. The ESR of about 5Ω or less and resonant frequency above 500KHz are most important parameter in the value of Capacitor. The Capacitors value can be increased without any limit. At lower values of output current, less output capacitance is required for stability. For the currents below 10mA the value of capacitor can be reduce to 0.33uF and 0.1uF for 1mA. More output capacitance needed for the 8-pin version at voltage below 5V since it runs the error amplifier at lower gain. At worst case 3.3uF or greater must be used for condition of 100mA load at 1.250V output.

The TS2950/A & TS2951/A is not like other low dropout regulators will remain stable and regulation with no load in addition to the internal voltage divider. This feature very important in application, it is like CMOS RAM keep-alive. The TS2951/A output voltage is set with minimum load of 1uA and external resistors.

If at the input of TS2950/A & TS2951/A connected to battery or between AC filter capacitor and input is 10 inches wire then 1uF tantalum or aluminum electrolytic capacitor should be connected between input and ground. Instability can occur if stray capacitor to feedback terminal pin 7 of the TS2951/A. This could cause more problems when using higher value of external to set the output voltage. To fix this problem the 100pF capacitor between output and feedback and increasing output capacitance to 3.3uF.

Reducing Output Noise

It could be an advantage to reduce the AC noise present at the output. One method is to reduce the regulator bandwidth by increasing the value of the output capacitor. This is the only method that noise could reduce on the TS2950/A & TS2951/A, but is relatively inefficient, as increasing capacitor from 1uF to 220uF only decreases the noise from 430uV to 160uVrms for a 100KHz bandwidth at 5V output. Noise could be also reduced by fourfold by a bypass capacitor across R1 since it reduces the high frequency gain from 4 to unity.

Pick $C_{bypass} = 1 / 2\pi R1 * 200Hz$ or choose 0.01uF when doing this, the output capacitor must be increased to 3.3uF to maintain stability. These change the output noise from 430uV/rms for a 100 kHz bandwidth 5V, 3.3V & 3V output. With the bypass capacitor added, noise no longer scales with output voltage so that improvements are more dramatic higher output voltage.

Error Detection Comparator Output

The Compactor produces a logic low output whenever the TS2951/A output falls of regulation by more than around 5%. This is around 60 mV offset divided by the 1.235 reference voltage. Thus trip remains 5% below nominal regardless of the programmed output voltage of the regulator. The Figure 1 shows the timing diagram depicting the ERROR signal and the regulator output voltage as the TS2951/A input is ramped up and down. The ERROR signal becomes low at around 1.3V input, it goes high around 5V input (input voltage at which $V_{out}=4.75V$). The TS2951/A dropout voltage depending on the load, the input voltage trip point around 5V will vary with load current. The output voltage trip point is around 4.75V, it does not change with load. The error comparator has an open-collector output which requires an external pull-up resistor. Depending on the system requirement, the resistor maybe returned to 5 or 3.3V output or other supply voltage depending to the system requirements. For determining the size of the resistor, note that the output is sinking 400uA, this value adds to battery drain in a low better condition, recommended values 100K to 1MΩ. If the output is unused this resistor is not required.

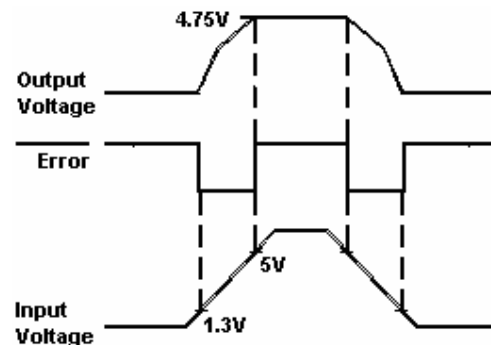

Figure 1. Error Output Timing

Application Hints (continued)

Programming The output Voltage

The TS2951/A output voltage is programmable for any value from its reference voltage of 1.235V and its maximum rating of 30V. For example, for 5V, you need to pin-strapped and use the internal voltage divider by tying pin 1 to 2 and pin 7 to pin 6. Refer to Figure 2; there are two external resistors required for this programming. Refer to the below equation for programming the output voltage:

$$V_{out} = V_{ref} \times (1 + R1/R2) + I_{FB} \times R1$$

The V_{ref} is 1.235V and I_{FB} is the feedback bias current, nominally -20nA. The minimum recommended load current of 1uA forces an upper limit of 1.2MΩ on the value of $R2$. If no load is presented, the I_{FB} produces an error of typically 2% in V_{out} which may be eliminated at room temperature by trimming $R1$. To improve accuracy, choose the value of $R2=100K$ and this reduces the error by 0.17% and increases the resistor program current by 12uA. The TS2951/A typically draws 60uA at no load with pin 2 open-circuit, and this value does not look much.

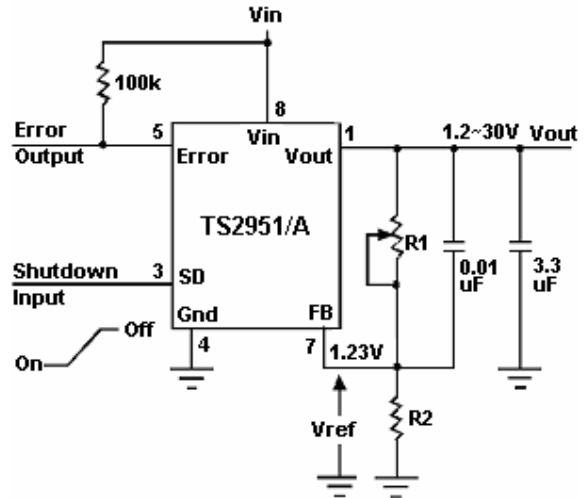

Note: Pin 2 and 6 are left open

Figure 2. Adjust Voltage

Block Diagram and Typical Applications Circuit

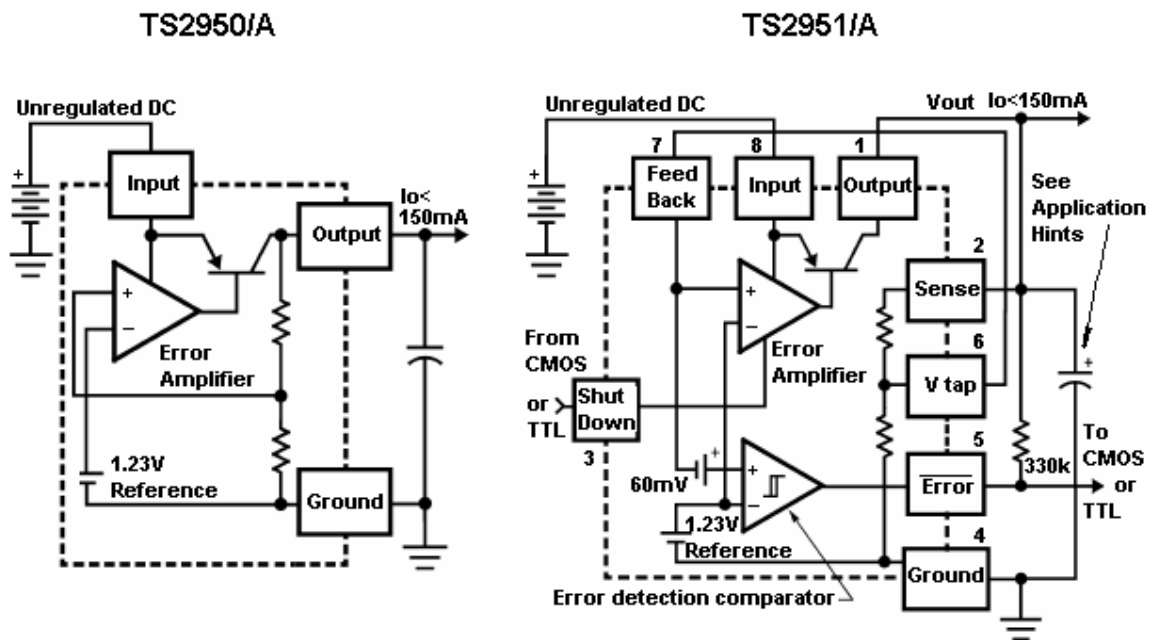

TO-92 Mechanical Drawing

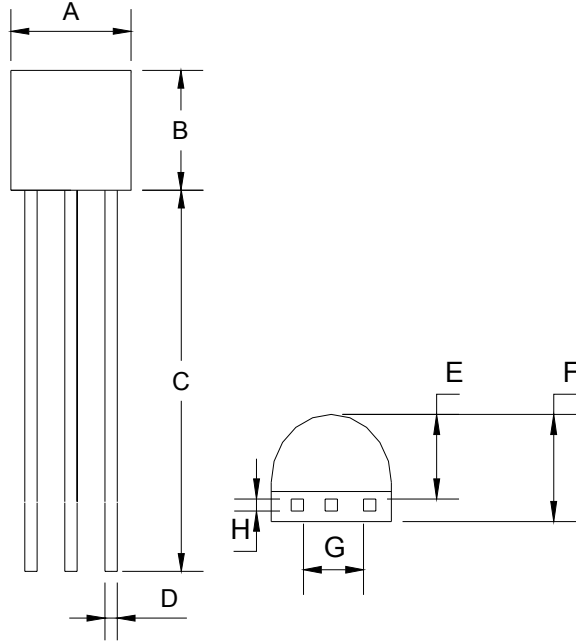

TO-92 DIMENSION				
DIM	MILLIMETERS		INCHES	
	MIN	MAX	MIN	MAX
A	4.30	4.70	0.169	0.185
B	4.30	4.70	0.169	0.185
C	14.30(typ)		0.563(typ)	
D	0.43	0.49	0.017	0.019
E	2.19	2.81	0.086	0.111
F	3.30	3.70	0.130	0.146
G	2.42	2.66	0.095	0.105
H	0.37	0.43	0.015	0.017

SOP-8 Mechanical Drawing

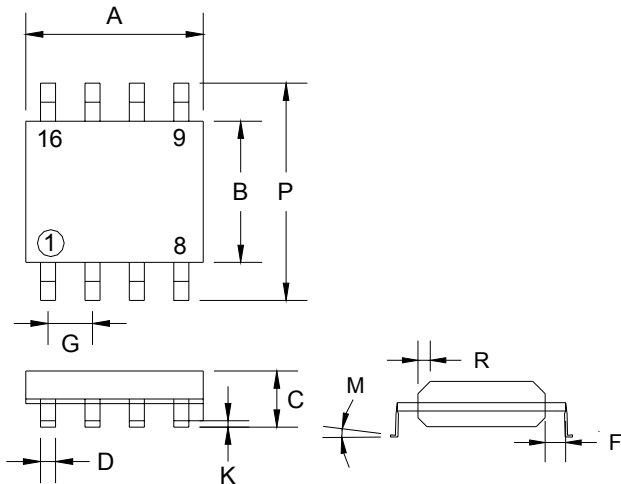

SOP-8 DIMENSION				
DIM	MILLIMETERS		INCHES	
	MIN	MAX	MIN	MAX
A	4.80	5.00	0.189	0.196
B	3.80	4.00	0.150	0.157
C	1.35	1.75	0.054	0.068
D	0.35	0.49	0.014	0.019
F	0.40	1.25	0.016	0.049
G	1.27 (typ)		0.05 (typ)	
K	0.10	0.25	0.004	0.009
M	0°	7°	0°	7°
P	5.80	6.20	0.229	0.244
R	0.25	0.50	0.010	0.019