



**OP07C**

## VERY LOW OFFSET SINGLE BIPOLAR OPERATIONAL AMPLIFIER

- EXTREMELY LOW OFFSET : 150 $\mu$ V/ max.
- LOW INPUT BIAS CURRENT : 1.8nA
- LOW  $V_{io}$  DRIFT : 0.5 $\mu$ V/ $^{\circ}$ C
- ULTRA STABLE WITH TIME :  
2 $\mu$ V/month max.
- WIDE SUPPLY VOLTAGE RANGE :  
 $\pm$ 3V to  $\pm$ 22V

### DESCRIPTION

The OP07 is a very high precision op amp with an offset voltage maximum of 150 $\mu$ V.

Offering also low input current (1.8nA) and high gain (400V/mV), the OP07C is particularly suitable for instrumentation applications.

### ORDER CODE

Part Number	Temperature Range	Package
		N
OP07C	-40 $^{\circ}$ C, +105 $^{\circ}$ C	•

N = Dual in Line Package (DIP)



### PIN CONNECTIONS (top view)

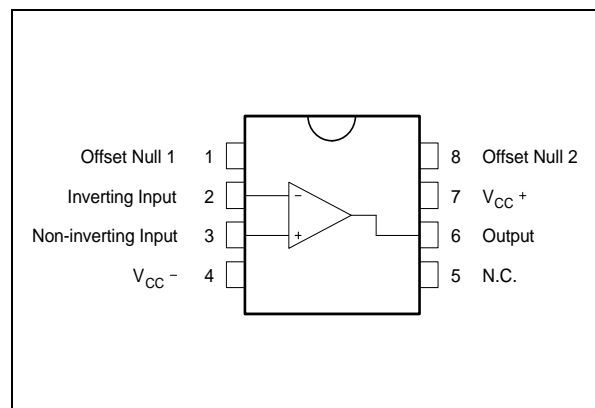

**SCHEMATIC DIAGRAM**

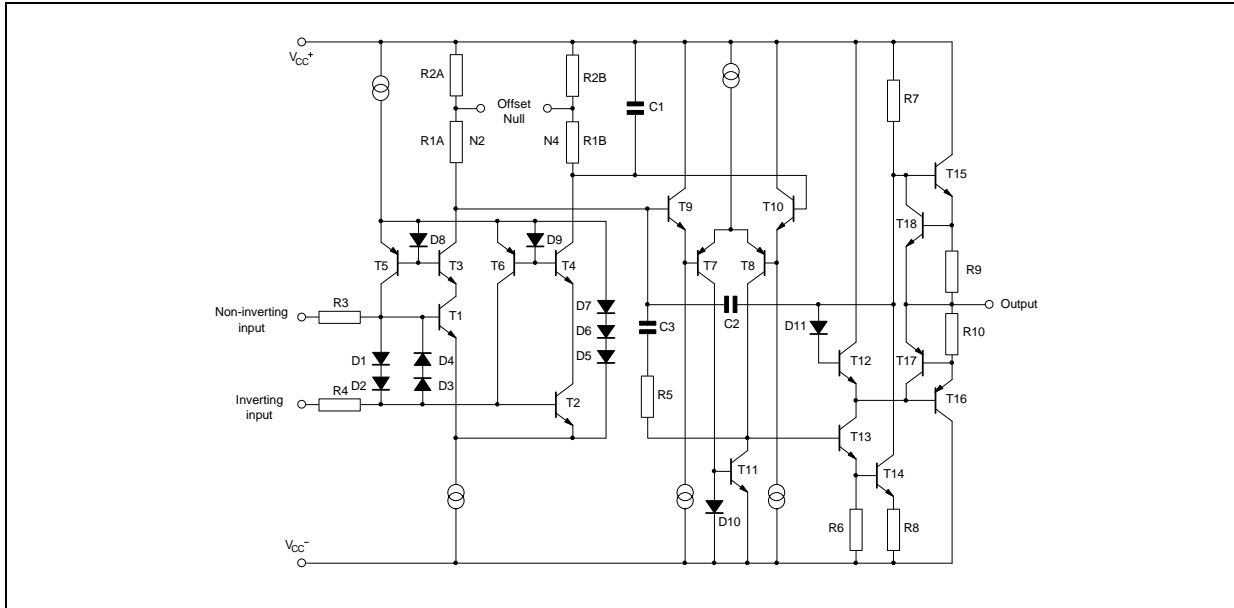

**INPUT OFFSET VOLTAGE NULLING CIRCUIT**

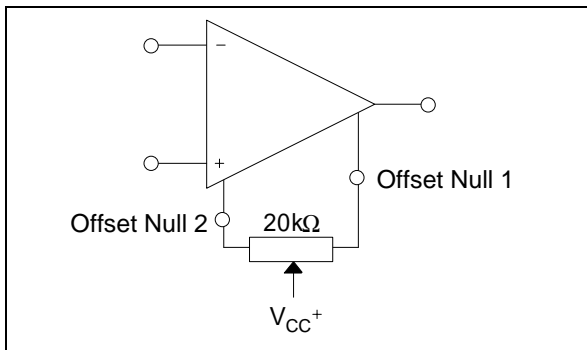

**ABSOLUTE MAXIMUM RATINGS**

Symbol	Parameter	Value	Unit
$V_{CC}$	Supply Voltage	$\pm 22$	V
$V_{id}$	Differential Input Voltage	$\pm 30$	V
$V_i$	Input Voltage	$\pm 22$	V
$T_{oper}$	Operating Temperature	-40 to +105	°C
$T_{stg}$	Storage Temperature	-65 to +150	°C

**ELECTRICAL CHARACTERISTICS**
 $V_{CC} = \pm 15V$ ,  $T_{amb} = 25^{\circ}C$  (unless otherwise specified)

Symbol	Parameter	Min.	Typ.	Max.	Unit
$V_{io}$	Input Offset Voltage $0^{\circ}C \leq T_{amb} \leq +105^{\circ}C$		60	150 250	$\mu V$
	Long Term Input Offset - Voltage Stability - note <sup>1)</sup>		0.4	2	$\mu V/Mo$
$DV_{io}$	Input Offset Voltage Drift		0.5	1.8	$\mu V/^{\circ}C$
$I_{io}$	Input Offset Current ( $V_{ic} = 0V$ ) $0^{\circ}C \leq T_{amb} \leq +105^{\circ}C$		0.8	6 7	nA
$DI_{io}$	Input Offset Current Drift		15	50	$pA/^{\circ}C$
$I_{ib}$	Input Bias Current $0^{\circ}C \leq T_{amb} \leq +105^{\circ}C$		1.8	7 9	nA
$DI_{ib}$	Input Bias Current Drift		15	50	$pA/^{\circ}C$
$R_O$	Open Loop Output Resistance		60		$\Omega$
$R_{id}$	Differential Input Resistance		33		$M\Omega$
$R_{ic}$	Common Mode Input Resistance		120		$G\Omega$
$V_{icm}$	Input Common Mode Voltage Range $0^{\circ}C \leq T_{amb} \leq +105^{\circ}C$	$\pm 13$ $\pm 13$	$\pm 13.5$		V
CMR	Common-mode Rejection Ratio ( $V_{ic} = V_{icm \text{ min.}}$ ) $0^{\circ}C \leq T_{amb} \leq +105^{\circ}C$	100 97	120		dB
SVR	Supply Voltage Rejection Ratio ( $V_{CC} = \pm 3$ to $\pm 18V$ ) $0^{\circ}C \leq T_{amb} \leq +105^{\circ}C$	90 86	104		dB
$A_{vd}$	Large Signal Voltage Gain $V_{CC} = \pm 15$ , $R_L = 2k\Omega$ , $V_O = \pm 10V$ $0^{\circ}C \leq T_{amb} \leq +105^{\circ}C$ $V_{CC} = \pm 3$ , $R_L = 500\Omega$ , $V_O = \pm 0.5V$	120 100 100	400 400		V/mV
$V_{opp}$	Output Voltage Swing $R_L = 10k\Omega$ $R_L = 2k\Omega$ $R_L = 1k\Omega$ $R_L = 2k\Omega$ $0^{\circ}C \leq T_{amb} \leq +105^{\circ}C$	$\pm 12$ $\pm 11.5$  $\pm 11$	$\pm 13$ $\pm 12.8$ $\pm 12$		V
SR	Slew Rate ( $R_L = 2k\Omega$ , $C_L = 100pF$ )		0.17		V/ $\mu s$
GBP	Gain Bandwidth Product ( $R_L = 2k\Omega$ , $C_L = 100pF$ , $f = 100kHz$ )		0.5		MHz
$I_{CC}$	Supply Current - no load $0^{\circ}C \leq T_{amb} \leq +105^{\circ}C$ $V_{CC} = \pm 3V$		2.7 0.67	5 6 1.3	mA
$e_n$	Equivalent Input Noise Voltage $f = 10kHz$ $f = 100Hz$ $f = 1kHz$		11 10.5 10	20 13.5 11.5	$\frac{nV}{\sqrt{Hz}}$
$i_n$	Equivalent Input Noise Current $f = 10kHz$ $f = 100Hz$ $f = 1kHz$		0.3 0.2 0.1	0.9 0.3 0.2	$\frac{pA}{\sqrt{Hz}}$

1. Long term input offset voltage stability refers to the average trend line of  $V_{io}$  vs time over extended periods after the first 30 days of operation.

PACKAGE MECHANICAL DATA

Plastic DIP-8 MECHANICAL DATA						
DIM.	mm.			inch		
	MIN.	TYP.	MAX.	MIN.	TYP.	MAX.
A		3.3			0.130	
a1	0.7			0.028		
B	1.39		1.65	0.055		0.065
B1	0.91		1.04	0.036		0.041
b		0.5			0.020	
b1	0.38		0.5	0.015		0.020
D			9.8			0.386
E		8.8			0.346	
e		2.54			0.100	
e3		7.62			0.300	
e4		7.62			0.300	
F			7.1			0.280
I			4.8			0.189
L		3.3			0.130	
Z	0.44		1.6	0.017		0.063

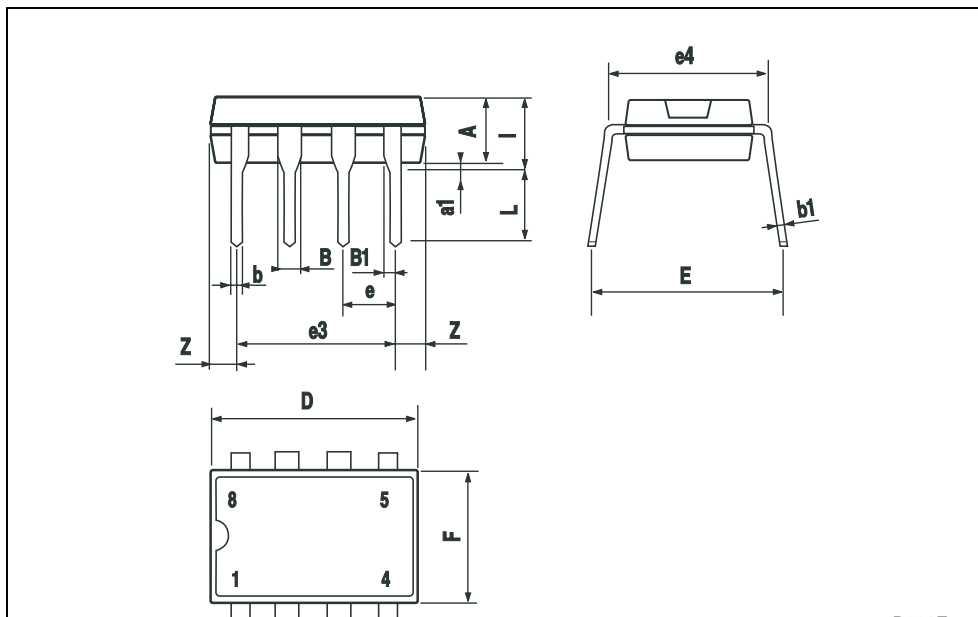

Information furnished is believed to be accurate and reliable. However, STMicroelectronics assumes no responsibility for the consequences of use of such information nor for any infringement of patents or other rights of third parties which may result from its use. No license is granted by implication or otherwise under any patent or patent rights of STMicroelectronics. Specifications mentioned in this publication are subject to change without notice. This publication supersedes and replaces all information previously supplied. STMicroelectronics products are not authorized for use as critical components in life support devices or systems without express written approval of STMicroelectronics.

The ST logo is a registered trademark of STMicroelectronics

© 2003 STMicroelectronics - All Rights Reserved  
 STMicroelectronics GROUP OF COMPANIES

Australia - Brazil - China - Finland - France - Germany - Hong Kong - India - Italy - Japan - Malaysia - Malta - Morocco  
 Singapore - Spain - Sweden - Switzerland - United Kingdom

<http://www.st.com>

This datasheet has been download from:

[www.datasheetcatalog.com](http://www.datasheetcatalog.com)

Datasheets for electronics components.