

## 2.5V to 5.5V Micropower CMOS Op Amps

### Features

- Low Input Offset Voltage: 250  $\mu$ V (max.)
- Rail-to-Rail Output
- Low Input Bias Current: 80 pA (max. at 85°C)
- Low Quiescent Current: 25  $\mu$ A (max.)
- Power Supply Voltage: 2.5V to 5.5V
- Unity-Gain Stable
- Chip Select ( $\overline{\text{CS}}$ ) Capability: **MCP608**
- Industrial Temperature Range: -40°C to +85°C
- No Phase Reversal
- Available in Single, Dual and Quad Packages

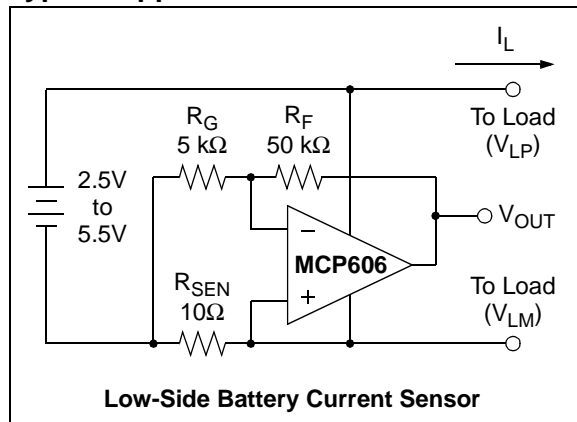
### Typical Applications

- Battery Power Instruments
- High-Impedance Applications
  - Photodiode Amplifier
  - pH Probe Buffer Amplifier
  - Infrared Detectors
  - Precision Integrators
  - Charge Amplifier for Piezoelectric Transducers
- Strain Gauges
- Medical Instruments
- Test Equipment

### Available Tools

- SPICE Macro Models (at [www.microchip.com](http://www.microchip.com))
- FilterLab<sup>®</sup> Software (at [www.microchip.com](http://www.microchip.com))

### Typical Application

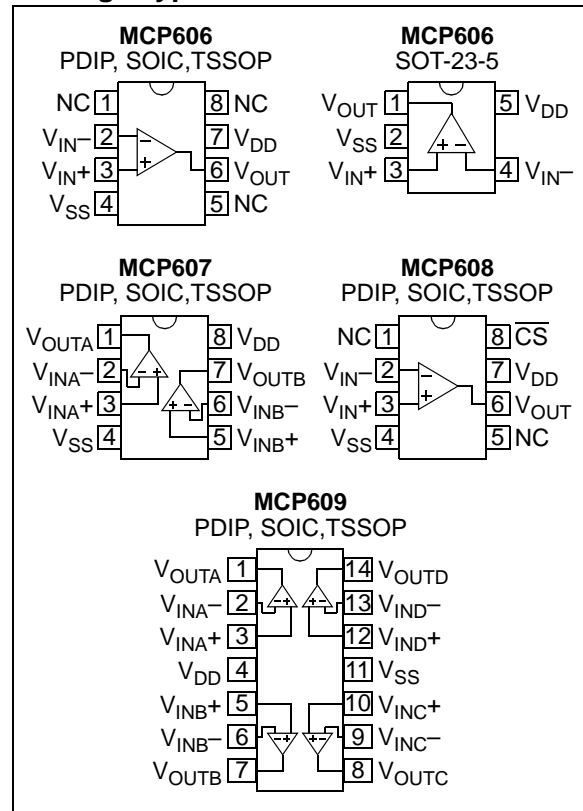


### Description

The MCP606/7/8/9 family of operational amplifiers (op amps) from Microchip Technology Inc. are unity-gain stable with low offset voltage (250  $\mu$ V, max.). Performance characteristics include rail-to-rail output swing capability and low input bias current (80 pA at +85°C, max.). These features make this family of op amps well suited for single-supply, precision, high-impedance, battery-powered applications.

The single MCP606 is available in standard 8-lead PDIP, SOIC and TSSOP packages, as well as in a SOT-23-5 package. The single MCP608 with Chip Select (CS) is offered in standard 8-lead PDIP, SOIC and TSSOP packages. The dual MCP607 is offered in standard 8-lead PDIP, SOIC and TSSOP packages. Finally, the quad MCP609 is offered in standard 14-lead PDIP, SOIC and TSSOP packages. All devices are fully specified from -40°C to +85°C, with power supplies from 2.5V to 5.5V.

### Package Types



# MCP606/7/8/9

## 1.0 ELECTRICAL CHARACTERISTICS

### Absolute Maximum Ratings †

$V_{DD} - V_{SS}$ .....	7.0V
All Inputs and Outputs .....	$V_{SS} - 0.3V$ to $V_{DD} + 0.3V$
Difference Input Voltage .....	$ V_{DD} - V_{SS} $
Output Short Circuit Current .....	continuous
Current at Input Pins .....	$\pm 2$ mA
Current at Output and Supply Pins .....	$\pm 30$ mA
Storage temperature .....	$-65^{\circ}\text{C}$ to $+150^{\circ}\text{C}$
Maximum Junction Temperature ( $T_J$ ) .....	$+150^{\circ}\text{C}$
ESD protection on all pins (HBM;MM) .....	2 kV; 200V

† **Notice:** Stresses above those listed under “Absolute Maximum Ratings” may cause permanent damage to the device. This is a stress rating only and functional operation of the device at those or any other conditions above those indicated in the operational listings of this specification is not implied. Exposure to maximum rating conditions for extended periods may affect device reliability.

### DC CHARACTERISTICS

Electrical Characteristics: Unless otherwise indicated, $V_{DD} = +2.5V$ to $+5.5V$ , $V_{SS} = \text{GND}$ , $T_A = +25^{\circ}\text{C}$ , $V_{CM} = V_{DD}/2$ , $V_{OUT} \approx V_{DD}/2$ and $R_L = 100$ k $\Omega$ to $V_{DD}/2$ .						
Parameters	Sym	Min	Typ	Max	Units	Conditions
<b>Input Offset</b>						
Input Offset Voltage	$V_{OS}$	-250	—	+250	$\mu\text{V}$	
Input Offset Drift with Temperature	$\Delta V_{OS}/\Delta T_A$	—	$\pm 1.8$	—	$\mu\text{V}/^{\circ}\text{C}$	$T_A = -40^{\circ}\text{C}$ to $+85^{\circ}\text{C}$
Power Supply Rejection Ratio	PSRR	80	93	—	dB	
<b>Input Bias Current and Impedance</b>						
Input Bias Current	$I_B$	—	1	—	pA	
At Temperature	$I_B$	—	—	80	pA	$T_A = +85^{\circ}\text{C}$
Input Offset Bias Current	$I_{OS}$	—	1	—	pA	
Common Mode Input Impedance	$Z_{CM}$	—	$10^{13}  6$	—	$\Omega  \text{pF}$	
Differential Input Impedance	$Z_{DIFF}$	—	$10^{13}  6$	—	$\Omega  \text{pF}$	
<b>Common Mode</b>						
Common Mode Input Range	$V_{CMR}$	$V_{SS} - 0.3$		$V_{DD} - 1.1$	V	$\text{CMRR} \geq 75$ dB
Common Mode Rejection Ratio	CMRR	75	91	—	dB	$V_{DD} = 5V$ , $V_{CM} = -0.3V$ to $3.9V$
<b>Open-Loop Gain</b>						
DC Open-Loop Gain (Large-signal)	$A_{OL}$	105	121	—	dB	$R_L = 25$ k $\Omega$ to $V_{DD}/2$ , $V_{OUT} = 50$ mV to $V_{DD} - 50$ mV
DC Open-Loop Gain (Large-signal)	$A_{OL}$	100	118	—	dB	$R_L = 5$ k $\Omega$ to $V_{DD}/2$ , $V_{OUT} = 0.1V$ to $V_{DD} - 0.1V$
<b>Output</b>						
Maximum Output Voltage Swing	$V_{OL}, V_{OH}$	$V_{SS} + 15$	—	$V_{DD} - 20$	mV	$R_L = 25$ k $\Omega$ to $V_{DD}/2$ , 0.5V output overdrive
	$V_{OL}, V_{OH}$	$V_{SS} + 45$	—	$V_{DD} - 60$	mV	$R_L = 5$ k $\Omega$ to $V_{DD}/2$ , 0.5V output overdrive
Linear Output Voltage Range	$V_{OUT}$	$V_{SS} + 50$	—	$V_{DD} - 50$	mV	$R_L = 25$ k $\Omega$ to $V_{DD}/2$ , $A_{OL} \geq 105$ dB
	$V_{OUT}$	$V_{SS} + 100$	—	$V_{DD} - 100$	mV	$R_L = 5$ k $\Omega$ to $V_{DD}/2$ , $A_{OL} \geq 100$ dB
Output Short Circuit Current	$I_{SC}$	—	7	—	mA	$V_{DD} = 2.5V$
	$I_{SC}$	—	17	—	mA	$V_{DD} = 5.5V$
<b>Power Supply</b>						
Supply Voltage	$V_{DD}$	2.5	—	5.5	V	
Quiescent Current per Amplifier	$I_Q$	—	18.7	25	$\mu\text{A}$	$I_O = 0$

## AC CHARACTERISTICS

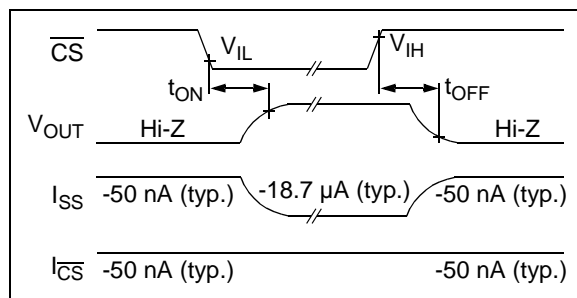
**Electrical Characteristics:** Unless otherwise indicated,  $V_{DD} = +2.5V$  to  $+5.5V$ ,  $V_{SS} = GND$ ,  $T_A = 25^\circ C$ ,  $V_{CM} = V_{DD}/2$ ,  $V_{OUT} \approx V_{DD}/2$ ,  $R_L = 100\text{ k}\Omega$  to  $V_{DD}/2$  and  $C_L = 60\text{ pF}$ .

Parameters	Sym	Min	Typ	Max	Units	Conditions
<b>AC Response</b>						
Gain Bandwidth Product	GBWP	—	155	—	kHz	
Phase Margin	PM	—	62	—	°	$G = +1$
Slew Rate	SR	—	0.08	—	V/ $\mu s$	$G = 1$
<b>Noise</b>						
Input Noise Voltage	$E_{ni}$	—	2.8	—	$\mu V_{P-P}$	$f = 0.1\text{ Hz to }10\text{ Hz}$
Input Noise Voltage Density	$e_{ni}$	—	38	—	nV/ $\sqrt{Hz}$	$f = 1\text{ kHz}$
Input Noise Current Density	$i_{ni}$	—	3	—	fA/ $\sqrt{Hz}$	$f = 1\text{ kHz}$

## MCP608 CHIP SELECT ( $\overline{CS}$ ) CHARACTERISTICS

**Electrical Characteristics:** Unless otherwise indicated,  $V_{DD} = +2.5V$  to  $+5.5V$ ,  $V_{SS} = GND$ ,  $T_A = 25^\circ C$ ,  $V_{CM} = V_{DD}/2$ ,  $V_{OUT} \approx V_{DD}/2$ ,  $R_L = 100\text{ k}\Omega$  to  $V_{DD}/2$  and  $C_L = 60\text{ pF}$ .

Parameters	Sym	Min	Typ	Max	Units	Conditions
<b><math>\overline{CS}</math> Low Specifications</b>						
$\overline{CS}$ Logic Threshold, Low	$V_{IL}$	$V_{SS}$	—	$0.2 V_{DD}$	V	
$\overline{CS}$ Input Current, Low	$I_{CSL}$	-0.1	0.01	—	$\mu A$	$\overline{CS} = 0.2V_{DD}$
<b><math>\overline{CS}</math> High Specifications</b>						
$\overline{CS}$ Logic Threshold, High	$V_{IH}$	$0.8 V_{DD}$	—	$V_{DD}$	V	
$\overline{CS}$ Input Current, High	$I_{CSH}$	—	0.01	0.1	$\mu A$	$\overline{CS} = V_{DD}$
$\overline{CS}$ Input High, GND Current	$I_{SS}$	-2	-0.05	—	$\mu A$	$\overline{CS} = V_{DD}$
Amplifier Output Leakage, $\overline{CS}$ High	$I_{O(LEAK)}$	—	10	—	nA	$\overline{CS} = V_{DD}$
<b><math>\overline{CS}</math> Dynamic Specifications</b>						
$\overline{CS}$ Low to Amplifier Output Turn-on Time	$t_{ON}$	—	9	100	$\mu s$	$\overline{CS} = 0.2V_{DD}$ to $V_{OUT} = 0.9(V_{DD}/2)$ , $G = +1\text{ V/V}$ , $R_L = 1\text{ k}\Omega$ to $V_{SS}$
$\overline{CS}$ High to Amplifier Output Hi-Z	$t_{OFF}$	—	0.1	—	$\mu s$	$\overline{CS} = 0.8V_{DD}$ to $V_{OUT} = 0.1(V_{DD}/2)$ , $G = +1\text{ V/V}$ , $R_L = 1\text{ k}\Omega$ to $V_{SS}$
$\overline{CS}$ Hysteresis	$V_{HYST}$	—	0.6	—	V	$V_{DD} = 5.0V$



**FIGURE 1-1:** Timing Diagram for the  $\overline{CS}$  Pin on the MCP608.

# MCP606/7/8/9

## TEMPERATURE CHARACTERISTICS

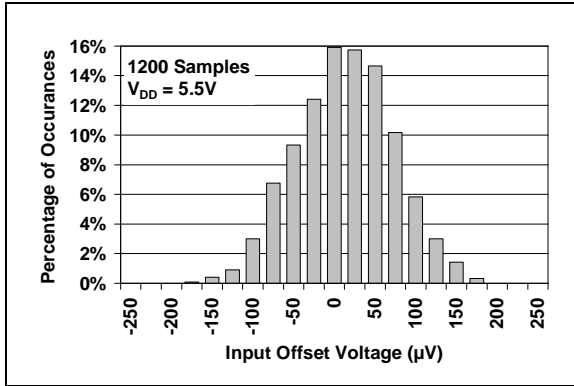
Electrical Characteristics: Unless otherwise indicated, $V_{DD} = +2.5V$ to $+5.5V$ and $V_{SS} = GND$ .						
Parameters	Sym	Min	Typ	Max	Units	Conditions
<b>Temperature Ranges</b>						
Specified Temperature Range	$T_A$	-40	—	+85	°C	
Operating Temperature Range	$T_A$	-40	—	+125	°C	<b>Note 1</b>
Storage Temperature Range	$T_A$	-65	—	+150	°C	
<b>Thermal Package Resistances</b>						
Thermal Resistance, 5L-SOT23	$\theta_{JA}$	—	256	—	°C/W	
Thermal Resistance, 8L-PDIP	$\theta_{JA}$	—	85	—	°C/W	
Thermal Resistance, 8L-SOIC	$\theta_{JA}$	—	163	—	°C/W	
Thermal Resistance, 8L-TSSOP	$\theta_{JA}$	—	124	—	°C/W	
Thermal Resistance, 14L-PDIP	$\theta_{JA}$	—	70	—	°C/W	
Thermal Resistance, 14L-SOIC	$\theta_{JA}$	—	120	—	°C/W	
Thermal Resistance, 14L-TSSOP	$\theta_{JA}$	—	100	—	°C/W	

**Note 1:** The MCP606/7/8/9 operate over this extended temperature range, but with reduced performance. In any case, the Junction Temperature ( $T_J$ ) must not exceed the Absolute Maximum specification of  $+150^\circ\text{C}$ .

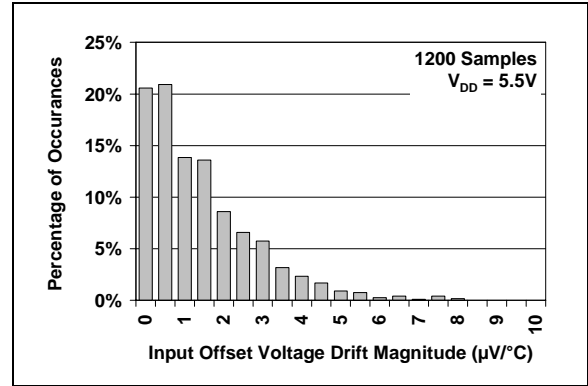
## 2.0 TYPICAL PERFORMANCE CURVES

**Note:** The graphs and tables provided following this note are a statistical summary based on a limited number of samples and are provided for informational purposes only. The performance characteristics listed herein are not tested or guaranteed. In some graphs or tables, the data presented may be outside the specified operating range (e.g., outside specified power supply range) and therefore outside the warranted range.

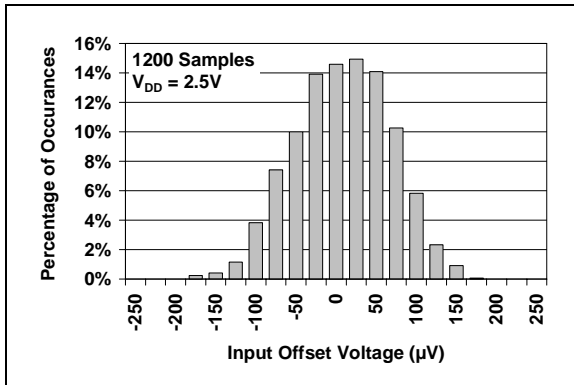
**Note:** Unless otherwise indicated,  $V_{DD} = +2.5V$  to  $+5.5V$ ,  $V_{SS} = GND$ ,  $T_A = 25^\circ C$ ,  $V_{CM} = V_{DD}/2$ ,  $V_{OUT} \approx V_{DD}/2$ ,  $R_L = 100\text{ k}\Omega$  to  $V_{DD}/2$  and  $C_L = 60\text{ pF}$ .



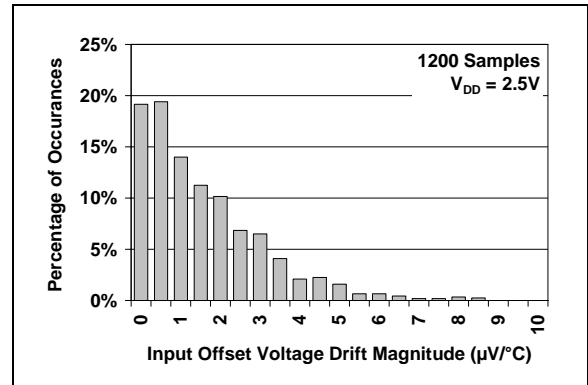
**FIGURE 2-1:** Input Offset Voltage at  $V_{DD} = 5.5V$ .



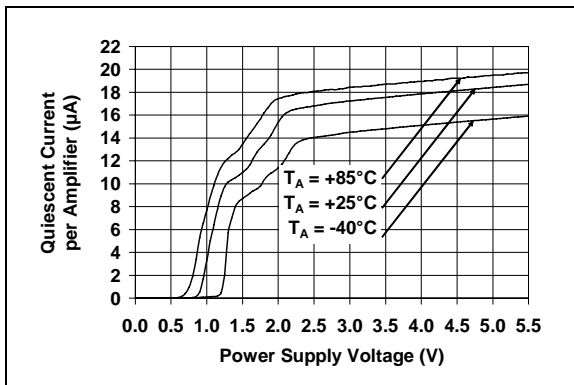
**FIGURE 2-4:** Input Offset Voltage Drift Magnitude at  $V_{DD} = 5.5V$ .



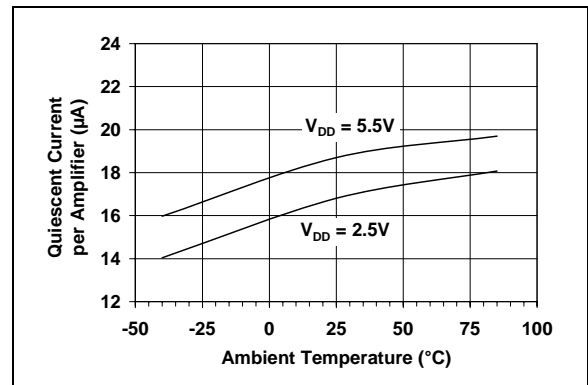
**FIGURE 2-2:** Input Offset Voltage at  $V_{DD} = 2.5V$ .



**FIGURE 2-5:** Input Offset Voltage Drift Magnitude at  $V_{DD} = 2.5V$ .



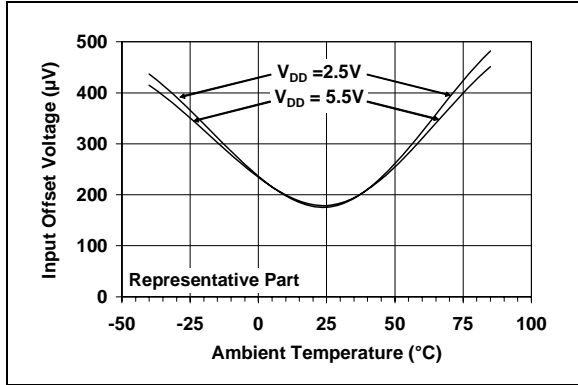
**FIGURE 2-3:** Quiescent Current vs. Power Supply Voltage.



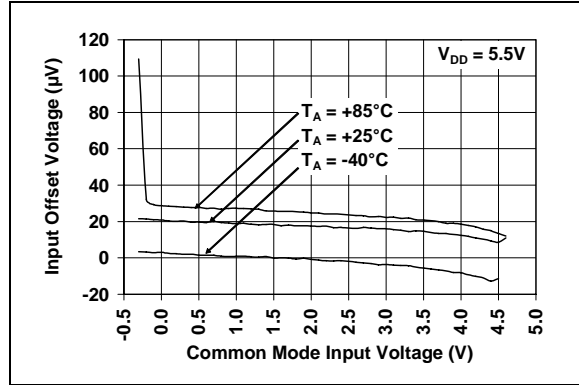
**FIGURE 2-6:** Quiescent Current vs. Ambient Temperature.

# MCP606/7/8/9

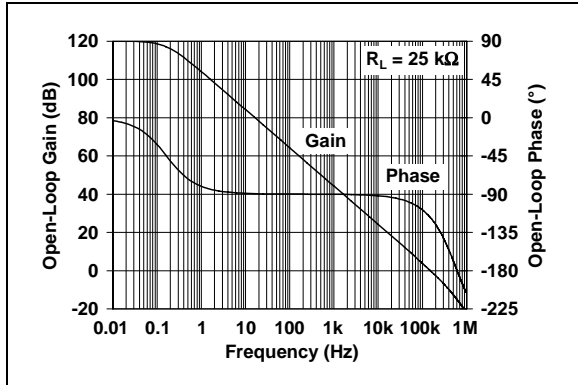
**Note:** Unless otherwise indicated,  $V_{DD} = +2.5V$  to  $+5.5V$ ,  $V_{SS} = GND$ ,  $T_A = 25^\circ C$ ,  $V_{CM} = V_{DD}/2$ ,  $V_{OUT} \approx V_{DD}/2$ ,  $R_L = 100\text{ k}\Omega$  to  $V_{DD}/2$  and  $C_L = 60\text{ pF}$ .



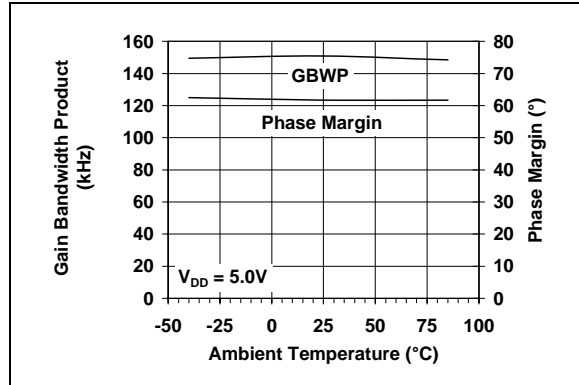
**FIGURE 2-7:** Input Offset Voltage vs. Ambient Temperature.



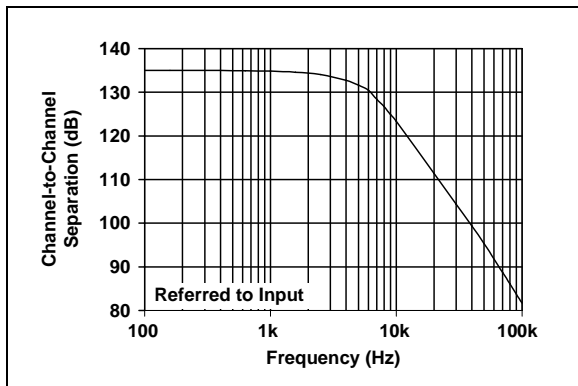
**FIGURE 2-10:** Input Offset Voltage vs. Common Mode Input Voltage.



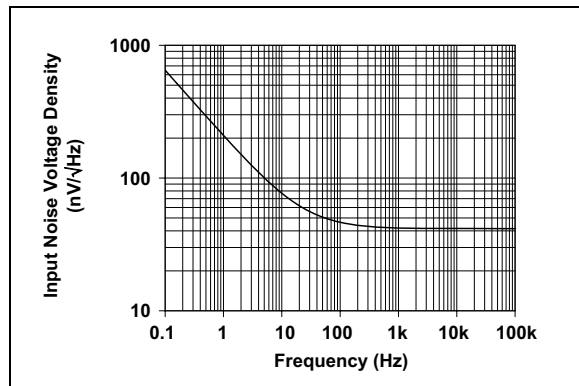
**FIGURE 2-8:** Open-Loop Gain and Phase vs. Frequency.



**FIGURE 2-11:** Gain Bandwidth Product, Phase Margin vs. Ambient Temperature.

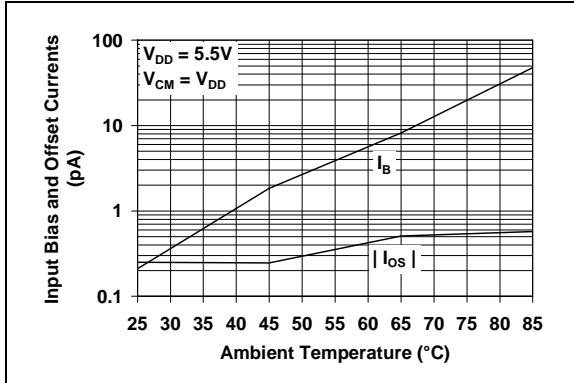


**FIGURE 2-9:** Channel-to-Channel Separation (MCP607 and MCP609 only).

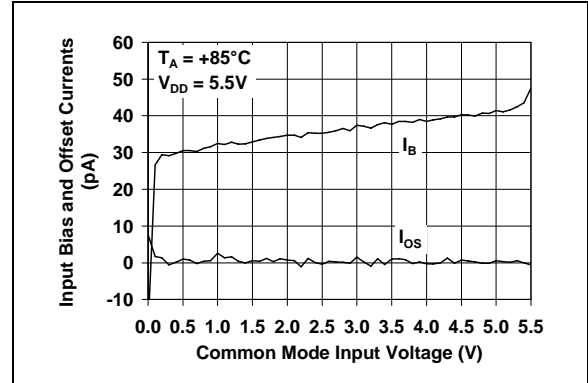


**FIGURE 2-12:** Input Noise Voltage Density vs. Frequency.

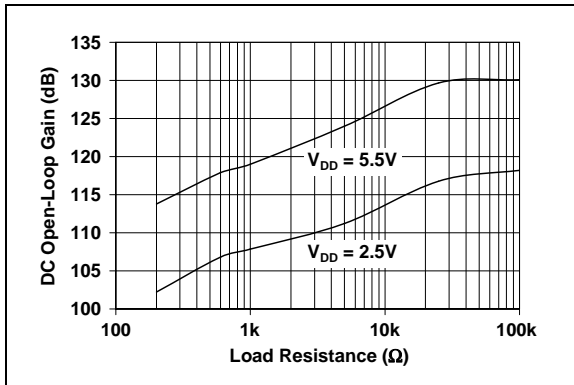
**Note:** Unless otherwise indicated,  $V_{DD} = +2.5V$  to  $+5.5V$ ,  $V_{SS} = GND$ ,  $T_A = 25^\circ C$ ,  $V_{CM} = V_{DD}/2$ ,  $V_{OUT} \approx V_{DD}/2$ ,  $R_L = 100\text{ k}\Omega$  to  $V_{DD}/2$  and  $C_L = 60\text{ pF}$ .



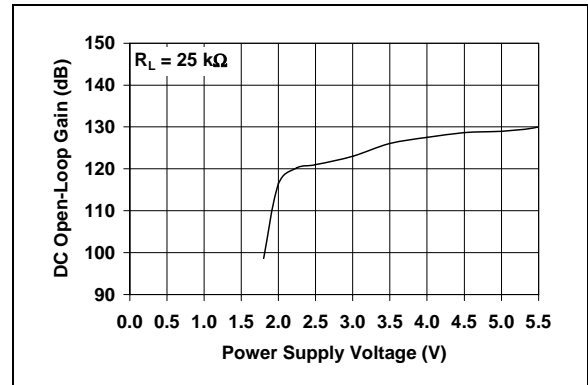
**FIGURE 2-13:** Input Bias Current, Input Offset Current vs. Ambient Temperature.



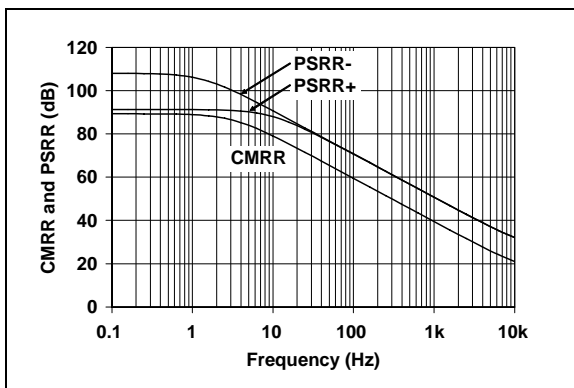
**FIGURE 2-16:** Input Bias Current, Input Offset Current vs. Common Mode Input Voltage.



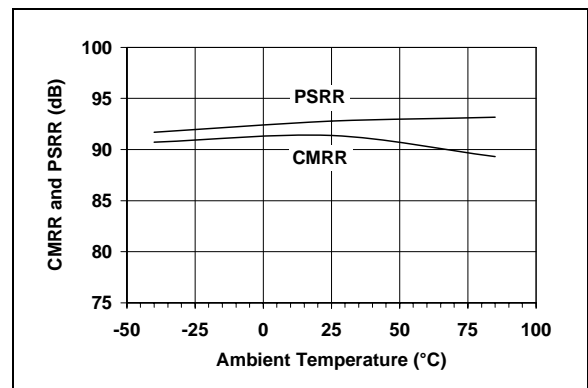
**FIGURE 2-14:** DC Open-Loop Gain vs. Load Resistance.



**FIGURE 2-17:** DC Open-Loop Gain vs. Power Supply Voltage.



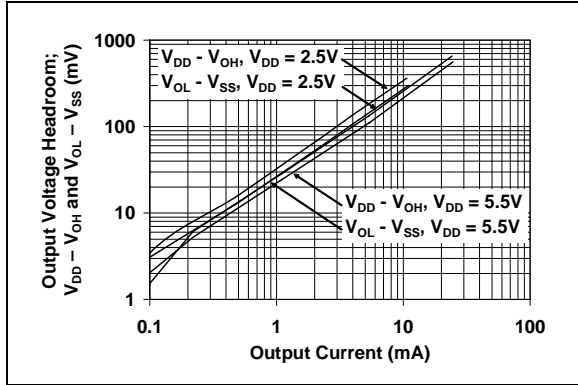
**FIGURE 2-15:** CMRR, PSRR vs. Frequency.



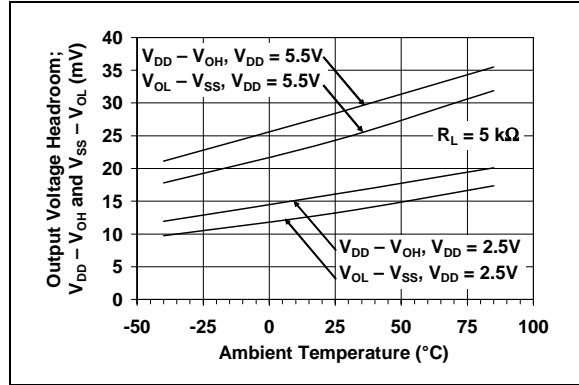
**FIGURE 2-18:** CMRR, PSRR vs. Ambient Temperature.

# MCP606/7/8/9

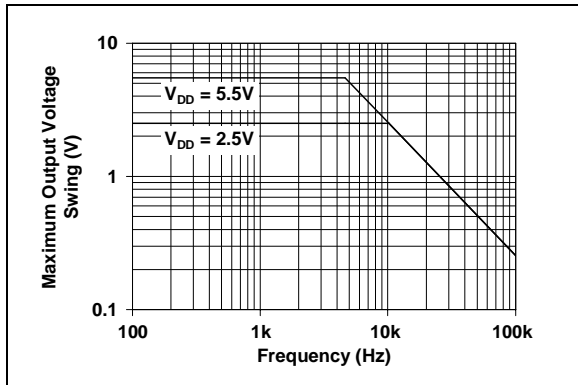
**Note:** Unless otherwise indicated,  $V_{DD} = +2.5V$  to  $+5.5V$ ,  $V_{SS} = GND$ ,  $T_A = 25^\circ C$ ,  $V_{CM} = V_{DD}/2$ ,  $V_{OUT} \approx V_{DD}/2$ ,  $R_L = 100\text{ k}\Omega$  to  $V_{DD}/2$  and  $C_L = 60\text{ pF}$ .



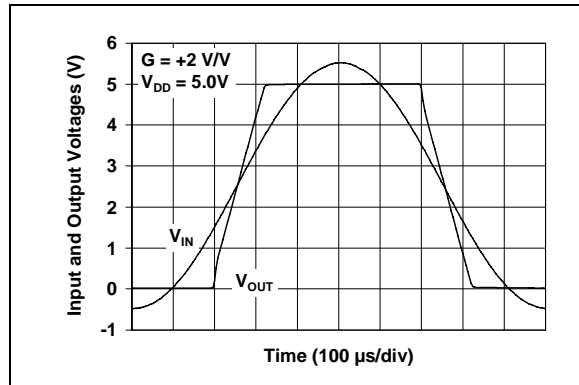
**FIGURE 2-19:** Output Voltage Headroom vs. Output Current Magnitude.



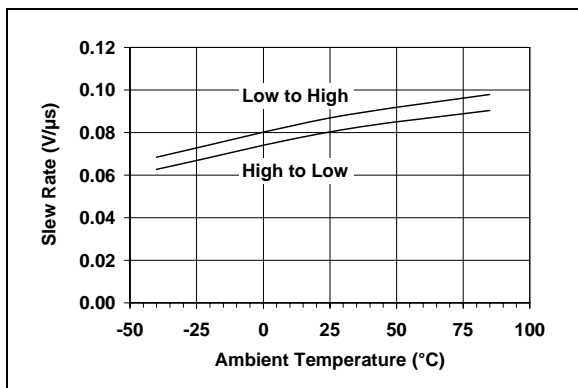
**FIGURE 2-22:** Output Voltage Headroom vs. Ambient Temperature at  $R_L = 5\text{ k}\Omega$ .



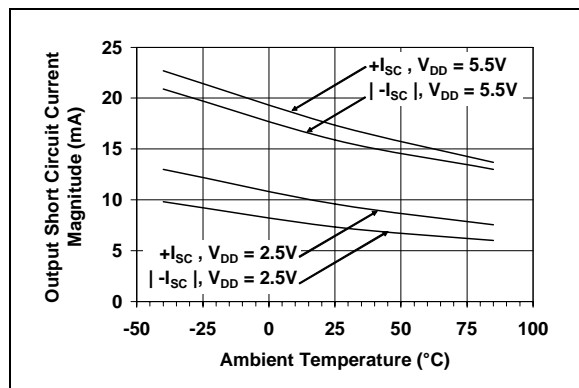
**FIGURE 2-20:** Maximum Output Voltage Swing vs. Frequency.



**FIGURE 2-23:** The MCP606/7/8/9 Show No Phase Reversal.



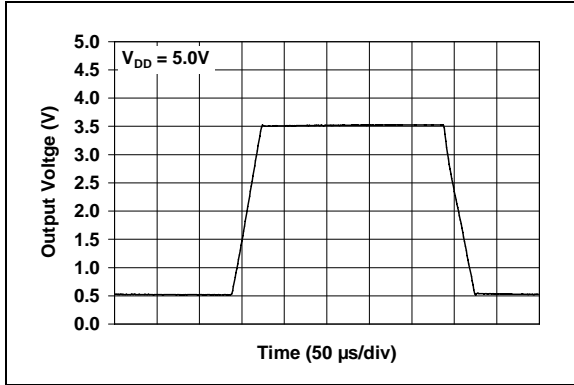
**FIGURE 2-21:** Slew Rate vs. Ambient Temperature.



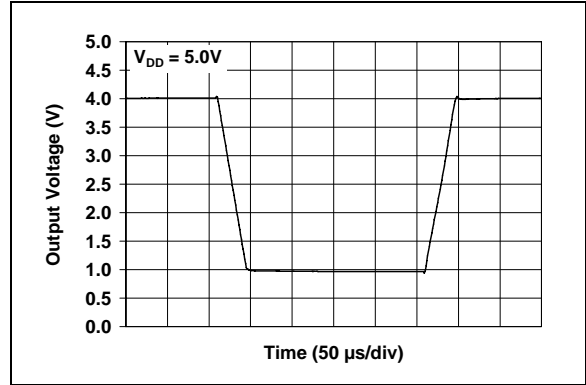
**FIGURE 2-24:** Output Short Circuit Current Magnitude vs. Ambient Temperature.



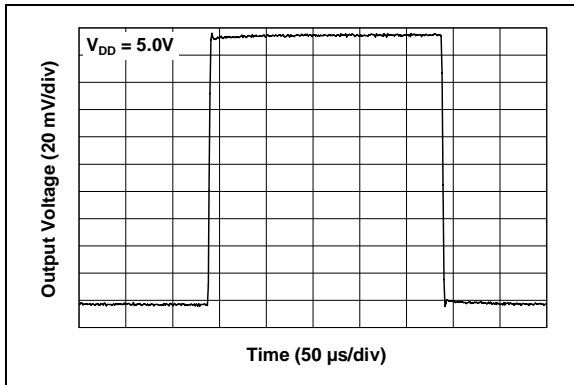
**Note:** Unless otherwise indicated,  $V_{DD} = +2.5V$  to  $+5.5V$ ,  $V_{SS} = GND$ ,  $T_A = 25^\circ C$ ,  $V_{CM} = V_{DD}/2$ ,  $V_{OUT} \approx V_{DD}/2$ ,  $R_L = 100\text{ k}\Omega$  to  $V_{DD}/2$  and  $C_L = 60\text{ pF}$ .



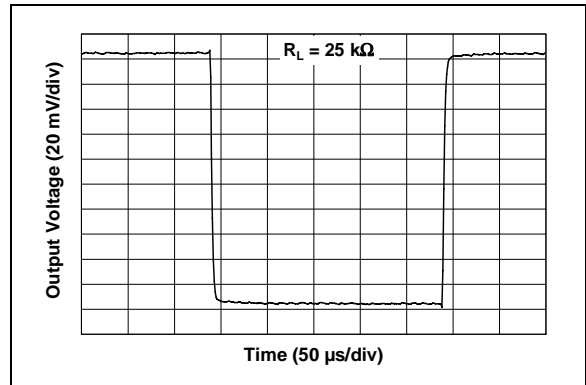
**FIGURE 2-25:** Large-signal, Non-inverting Pulse Response.



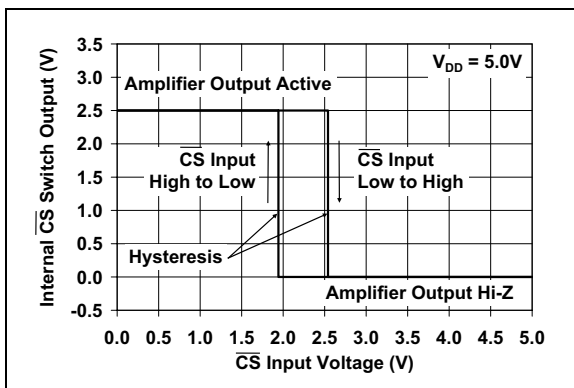
**FIGURE 2-28:** Large-signal, Inverting Pulse Response.



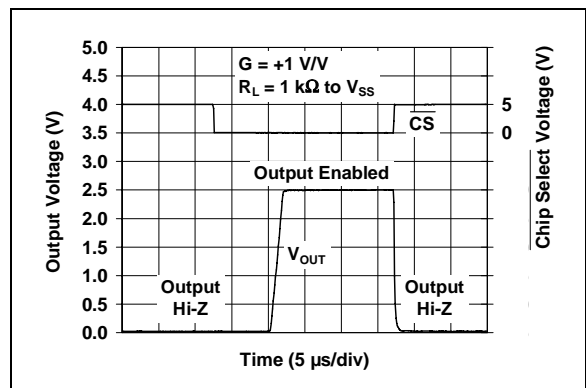
**FIGURE 2-26:** Small-signal, Non-inverting Pulse Response.



**FIGURE 2-29:** Small-signal, Inverting Pulse Response.



**FIGURE 2-27:** Chip Select ( $\overline{CS}$ ) Hysteresis (MCP608 only).



**FIGURE 2-30:** Amplifier Output Response Times vs. Chip Select ( $\overline{CS}$ ) Pulse (MCP608 only).

# MCP606/7/8/9

## 3.0 PIN DESCRIPTIONS

Descriptions of the pins are listed in Table 3-1.

TABLE 3-1: PIN FUNCTION TABLE.

MCP606 (PDIP, SOIC, TSSOP)	MCP606 (SOT-23-5)	MCP607	MCP608	MCP609	Symbol	Description
6	1	1	6	1	$V_{OUT}, V_{OUTA}$	Output (op amp A)
2	4	2	2	2	$V_{IN}^-, V_{INA}^-$	Inverting Input (op amp A)
3	3	3	3	3	$V_{IN}^+, V_{INA}^+$	Non-inverting Input (op amp A)
7	5	4	7	4	$V_{DD}$	Positive Power Supply
—	—	5	—	5	$V_{INB}^+$	Non-inverting Input (op amp B)
—	—	6	—	6	$V_{INB}^-$	Inverting Input (op amp B)
—	—	7	—	7	$V_{OUTB}$	Output (op amp B)
—	—	—	—	8	$V_{OUTC}$	Output (op amp B)
—	—	—	—	9	$V_{INC}^-$	Inverting Input (op amp C)
—	—	—	—	10	$V_{INC}^+$	Non-inverting Input (op amp C)
4	2	8	4	11	$V_{SS}$	Negative Power Supply
—	—	—	—	12	$V_{IND}^+$	Non-inverting Input (op amp D)
—	—	—	—	13	$V_{IND}^-$	Inverting Input (op amp D)
—	—	—	—	14	$V_{OUTD}$	Output (op amp D)
—	—	—	8	—	$\overline{CS}$	Chip Select
1, 5, 8	—	—	1, 5	—	NC	No Internal Connection

### 3.1 Analog Outputs

The output pins are low-impedance voltage sources.

### 3.2 Analog Inputs

The non-inverting and inverting inputs are high-impedance CMOS inputs with low bias currents.

### 3.3 Power Supply ( $V_{SS}$ and $V_{DD}$ )

The positive power supply pin ( $V_{DD}$ ) is 2.5V to 5.5V higher than the negative power supply pin ( $V_{SS}$ ). For normal operation, the output pins are at voltages between  $V_{SS}$  and  $V_{DD}$ ; while the input pins are at voltages between  $V_{SS} - 0.3V$  and  $V_{DD} + 0.3V$ .

Typically, these parts are used in a single-supply (positive) configuration. In this case,  $V_{SS}$  is connected to ground and  $V_{DD}$  is connected to the supply.  $V_{DD}$  will need a local bypass capacitor (typically 0.01  $\mu F$  to 0.1  $\mu F$ ) within 2 mm of the  $V_{DD}$  pin. These parts can share a bulk capacitor with nearby analog parts (typically 1  $\mu F$  or larger) within 100 mm of the  $V_{DD}$  pin.

### 3.4 Digital Input

The  $\overline{CS}$  pin is a Schmitt-triggered, CMOS logic input. It is used to place the MCP608 op amp in a Low-power mode, with the output(s) in a Hi-Z state.

## 4.0 APPLICATIONS INFORMATION

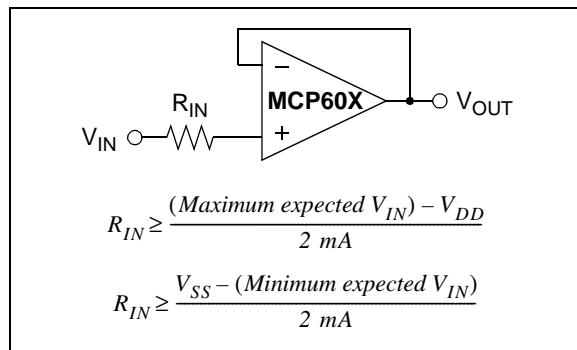
The MCP606/7/8/9 family of op amps is manufactured using Microchip's state-of-the-art CMOS process. These op amps are unity-gain stable and suitable for a wide range of general purpose applications.

### 4.1 Inputs

The MCP606/7/8/9 op amps are designed to prevent phase reversal when the input pins exceed the supply voltages. Figure 2-23 shows the input voltage exceeding the supply voltage without any phase reversal.

The inputs of the MCP606/7/8/9 op amps connect to a differential PMOS input stage. The Common Mode Input Voltage Range ( $V_{CMR}$ ) includes ground in single-supply systems ( $V_{SS}$ ), but does not include  $V_{DD}$ . This means that the amplifier input behaves linearly as long as the Common Mode Input Voltage ( $V_{CM}$ ) is kept within the specified  $V_{CMR}$  limits ( $V_{SS} - 0.3V$  to  $V_{DD} - 1.1V$  at  $+25^{\circ}C$ ).

Input voltages that exceed the Absolute Maximum Voltage Range ( $V_{SS} - 0.3V$  to  $V_{DD} + 0.3V$ ) can cause excessive current to flow into or out of the input pins. Current beyond  $\pm 2$  mA can cause reliability problems. Applications that exceed this rating must be externally limited with a resistor, as shown in Figure 4-1.



**FIGURE 4-1:** Input Current-Limiting Resistor ( $R_{IN}$ ).

### 4.2 Rail-to-Rail Output

There are two specifications that describe the output-swing capability of the MCP606/7/8/9 family of op amps. The first specification (Maximum Output Voltage Swing) defines the absolute maximum swing that can be achieved under the specified load conditions. For instance, the output voltage swings to within 15 mV of the negative rail with a 25 k $\Omega$  load to  $V_{DD}/2$ . Figure 2-23 shows how the output voltage is limited when the input goes beyond the linear region of operation.

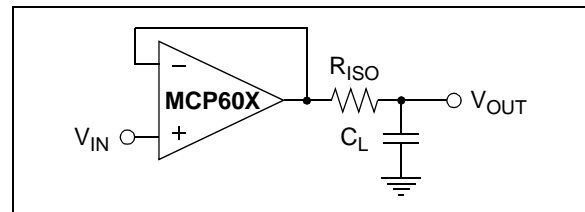
The second specification that describes the output-swing capability of these amplifiers (Linear Output Voltage Range) defines the maximum output swing that can be achieved while the amplifier still operates in its

linear region. To verify linear operation in this range, the large-signal DC Open-Loop Gain ( $A_{OL}$ ) is measured at points inside the supply rails. The measurement must meet the specified  $A_{OL}$  conditions in the specification table.

### 4.3 Capacitive Loads

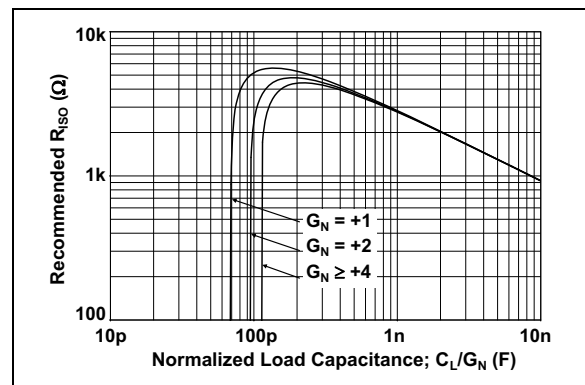
Driving large capacitive loads can cause stability problems for voltage-feedback op amps. As the load capacitance increases, the feedback loop's phase margin decreases and the closed-loop bandwidth is reduced. This produces gain-peaking in the frequency response, with overshoot and ringing in the step response. A unity-gain buffer ( $G = +1$ ) is the most sensitive to capacitive loads, though all gains show the same general behavior.

When driving large capacitive loads with these op amps (e.g.,  $> 60$  pF when  $G = +1$ ), a small series resistor at the output ( $R_{ISO}$  in Figure 4-2) improves the feedback loop's phase margin (stability) by making the output load resistive at higher frequencies. The bandwidth will be generally lower than the bandwidth with no capacitive load.



**FIGURE 4-2:** Output Resistor,  $R_{ISO}$  stabilizes large capacitive loads.

Figure 4-3 gives recommended  $R_{ISO}$  values for different capacitive loads and gains. The x-axis is the normalized load capacitance ( $C_L/G_N$ ), where  $G_N$  is the circuit's noise gain. For non-inverting gains,  $G_N$  and the Signal Gain are equal. For inverting gains,  $G_N$  is  $1 + |\text{Signal Gain}|$  (e.g.,  $-1$  V/V gives  $G_N = +2$  V/V).



**FIGURE 4-3:** Recommended  $R_{ISO}$  Values for Capacitive Loads.

# MCP606/7/8/9

After selecting  $R_{ISO}$  for your circuit, double-check the resulting frequency response peaking and step response overshoot. Modify  $R_{ISO}$ 's value until the response is reasonable. Bench evaluation and simulations with the MCP606/7/8/9 SPICE macro model are helpful.

## 4.4 MCP608 Chip Select ( $\overline{CS}$ )

The MCP608 is a single op amp with  $\overline{Chip\ Select}$  ( $\overline{CS}$ ). When  $\overline{CS}$  is pulled high, the supply current drops to 50 nA (typ.) and flows through the  $\overline{CS}$  pin to  $V_{SS}$ . When this happens, the amplifier output is put into a high-impedance state. By pulling  $\overline{CS}$  low, the amplifier is enabled. If the  $\overline{CS}$  pin is left floating, the amplifier may not operate properly. Figure 1-1 shows the output voltage and supply current response to a  $\overline{CS}$  pulse.

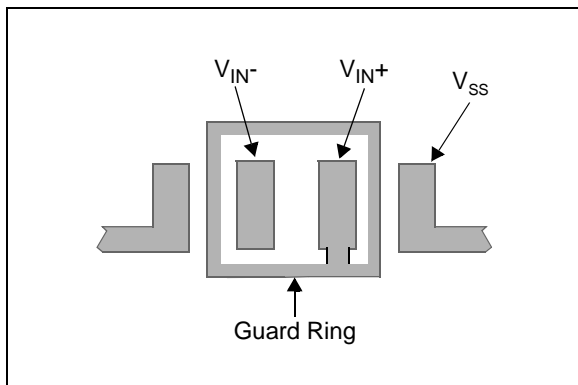
## 4.5 Supply Bypass

With this family of operational amplifiers, the power supply pin ( $V_{DD}$  for single-supply) should have a local bypass capacitor (i.e., 0.01  $\mu$ F to 0.1  $\mu$ F) within 2 mm for good high-frequency performance. It also needs a bulk capacitor (i.e., 1  $\mu$ F or larger) within 100 mm to provide large, slow currents. This bulk capacitor can be shared with other nearby analog parts.

## 4.6 PCB Surface Leakage

In applications where low input bias current is critical, Printed Circuit Board (PCB) surface-leakage effects need to be considered. Surface leakage is caused by humidity, dust or other contamination on the board. Under low humidity conditions, a typical resistance between nearby traces is  $10^{12}\Omega$ . A 5V difference would cause 5 pA of current to flow, which is greater than the MCP606/7/8/9 family's bias current at 25°C (1 pA, typ.).

The easiest way to reduce surface leakage is to use a guard ring around sensitive pins (or traces). The guard ring is biased at the same voltage as the sensitive pin. An example of this type of layout is shown in Figure 4-4.



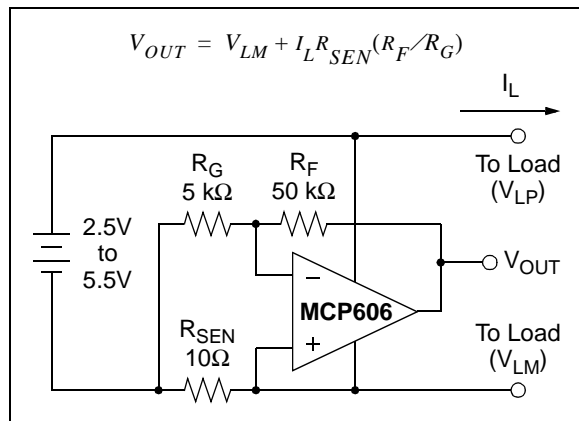
**FIGURE 4-4:** Example Guard Ring Layout for Inverting Gain.

1. Non-inverting Gain and Unity-gain Buffer:
  - a) Connect the non-inverting pin ( $V_{IN+}$ ) to the input with a wire that does not touch the PCB surface.
  - b) Connect the guard ring to the inverting input pin ( $V_{IN-}$ ). This biases the guard ring to the common mode input voltage.
2. Inverting Gain and Transimpedance Gain (convert current to voltage, such as photo detectors) amplifiers:
  - a) Connect the guard ring to the non-inverting input pin ( $V_{IN+}$ ). This biases the guard ring to the same reference voltage as the op amp (e.g.,  $V_{DD}/2$  or ground).
  - b) Connect the inverting pin ( $V_{IN-}$ ) to the input with a wire that does not touch the PCB surface.

## 4.7 Application Circuits

### 4.7.1 LOW-SIDE BATTERY CURRENT SENSOR

The MCP606/7/8/9 op amps can be used to sense the load current on the low-side of a battery using the circuit in Figure 4-5. In this circuit, the current from the power supply (minus the current required to power the MCP606) flows through a sense resistor ( $R_{SEN}$ ), which converts it to voltage. This is gained by the the amplifier and resistors,  $R_G$  and  $R_F$ . Since the non-inverting input of the amplifier is at the load's negative supply ( $V_{LM}$ ), the gain from  $R_{SEN}$  to  $V_{OUT}$  is  $R_F/R_G$ .



**FIGURE 4-5:** Low Side Battery Current Sensor.

Since the input bias current and input offset voltage of the MCP606 are low, and the input is capable of swinging below ground, there is very little error generated by the amplifier. The quiescent current is very low, which helps conserve battery power. The rail-to-rail output makes it possible to read very low currents.

## 4.7.2 PHOTODIODE AMPLIFIERS

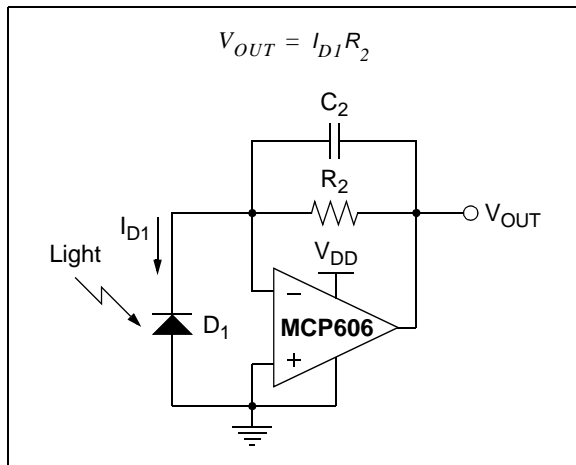
Sensors that produce an output current and have high output impedance can be connected to a transimpedance amplifier. The transimpedance amplifier converts the current into voltage. Photodiodes are one sensor that produce an output current.

The key op amp characteristics that are needed for these circuits are: low input offset voltage, low input bias current, high input impedance and an input common mode range that includes ground. The low input offset voltage and low input bias current support a very low voltage drop across the photodiode; this gives the best photodiode linearity. Since the photodiode is biased at ground, the op amp's input needs to function well both above and below ground.

### 4.7.2.1 Photo-Voltaic Mode

Figure 4-6 shows a transimpedance amplifier with a photodiode ( $D_1$ ) biased in the Photo-voltaic mode (0V across  $D_1$ ), which is used for precision photodiode sensing.

As light impinges on  $D_1$ , charge is generated, causing a current to flow in the reverse bias direction of  $D_1$ . The op amp's negative feedback forces the voltage across the  $D_1$  to be nearly 0V. Resistor  $R_2$  converts the current into voltage. Capacitor  $C_2$  limits the bandwidth and helps stabilize the circuit when  $D_1$ 's junction capacitance is large.



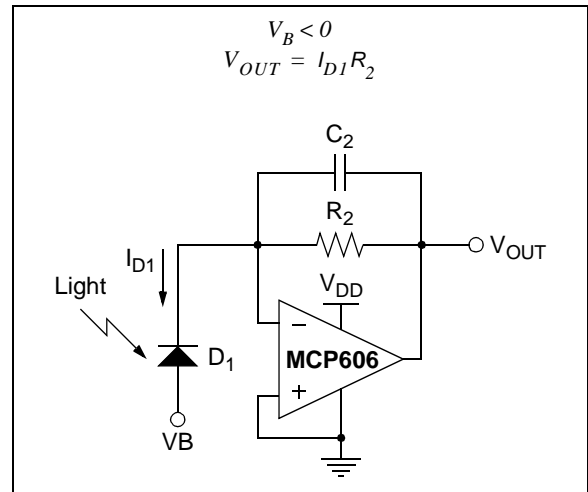
**FIGURE 4-6:** Photodiode (in Photo-voltaic mode) and Transimpedance Amplifier.

### 4.7.2.2 Photo-Conductive Mode

Figure 4-6 shows a transimpedance amplifier with a photodiode ( $D_1$ ) biased in the Photo-conductive mode ( $D_1$  is reverse biased), which is used for high-speed applications.

As light impinges on  $D_1$ , charge is generated, causing a current to flow in the reverse bias direction of  $D_1$ . Placing a negative bias on  $D_1$  significantly reduces its junction capacitance, which allows the circuit to

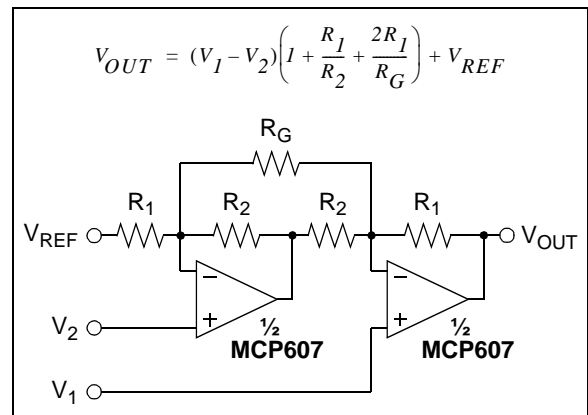
operate at a much higher speed. This reverse bias also increases the dark current and current noise, however. Resistor  $R_2$  converts the current into voltage. Capacitor  $C_2$  limits the bandwidth and helps stabilize the circuit when  $D_1$ 's junction capacitance is large.



**FIGURE 4-7:** Photodiode (in Photo-conductive mode) and Transimpedance Amplifier.

## 4.7.3 TWO OP AMP INSTRUMENTATION AMPLIFIER

The two op amp instrumentation amplifier shown in Figure 4-8 serves the function of taking the difference of two input voltages, level-shifting it and gaining it to the output. This configuration is best suited for higher gains (i.e., gain > 3 V/V). The reference voltage ( $V_{REF}$ ) is typically at mid-supply ( $V_{DD}/2$ ) in a single-supply environment.



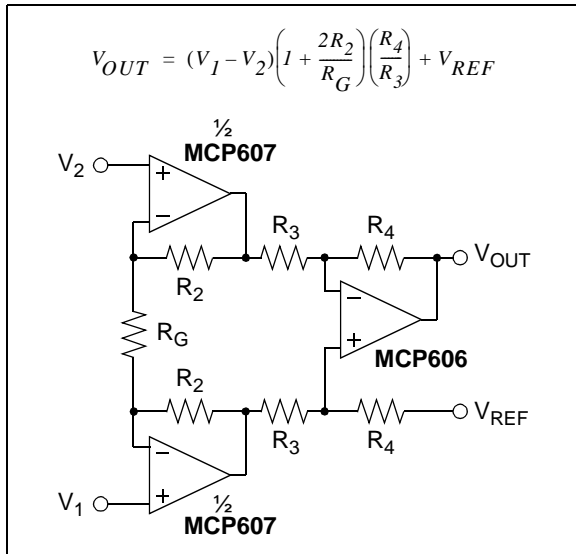
**FIGURE 4-8:** Two op amp Instrumentation Amplifier.

The key specifications that make the MCP606/7/8/9 family appropriate for this application circuit are low input bias current, low offset voltage and high common-mode rejection.

# MCP606/7/8/9

## 4.7.4 THREE OP AMP INSTRUMENTATION AMPLIFIER

A classic, three op amp instrumentation amplifier is illustrated in Figure 4-9. The two input op amps provide differential signal gain and a common mode gain of +1. The output op amp is a difference amplifier, which converts its input signal from differential to a single ended output; it rejects common mode signals at its input. The gain of this circuit is simply adjusted with one resistor ( $R_G$ ). The reference voltage ( $V_{REF}$ ) is typically referenced to mid-supply ( $V_{DD}/2$ ) in single-supply applications.

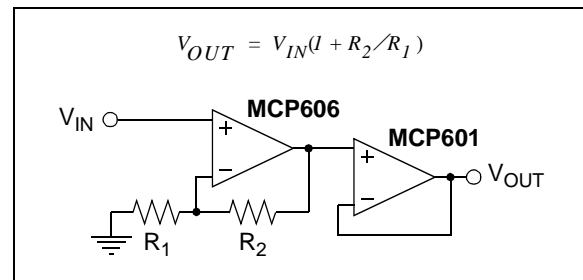


**FIGURE 4-9:** Three op amp Instrumentation Amplifier.

## 4.7.5 PRECISION GAIN WITH GOOD LOAD ISOLATION

In Figure 4-10, the MCP606 op amps,  $R_1$  and  $R_2$  provide a high gain to the input signal ( $V_{IN}$ ). The MCP606's low offset voltage makes this an accurate circuit.

The MCP601 is configured as a unity-gain buffer. It isolates the MCP606's output from the load, increasing the high-gain stage's precision. Since the MCP601 has a higher output current, with the two amplifiers being housed in separate packages, there is minimal change in the MCP606's offset voltage due to loading effect.



**FIGURE 4-10:** Precision Gain with Good Load Isolation.

## 5.0 DESIGN TOOLS

Microchip provides the basic design tools needed for the MCP606/7/8/9 family of op amps.

### 5.1 SPICE Macro Model

The latest SPICE macro model for the MCP606/7/8/9 op amps is available on our web site at [www.microchip.com](http://www.microchip.com). This model is intended to be an initial design tool that works well in the op amp's linear region of operation at room temperature. See the model file for information on its capabilities.

Bench testing is a very important part of any design and cannot be replaced with simulations. Also, simulation results using this macro model need to be validated by comparing them to the data sheet specifications and characteristic curves.

### 5.2 FilterLab<sup>®</sup> Software

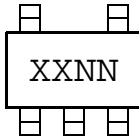
The FilterLab software is an innovative tool that simplifies analog active-filter (using op amps) design. It is available free of charge from our web site at [www.microchip.com](http://www.microchip.com). The FilterLab software tool provides full schematic diagrams of the filter circuit with component values. It also outputs the filter circuit in SPICE format, which can be used with the macro model to simulate actual filter performance.

# MCP606/7/8/9

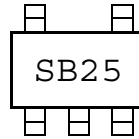
## 6.0 PACKAGING INFORMATION

### 6.1 Package Marking Information

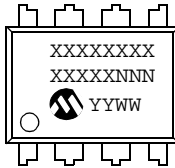
5-Lead SOT-23-5



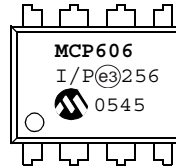
Example:



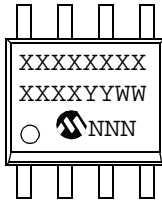
8-Lead PDIP (300 mil)



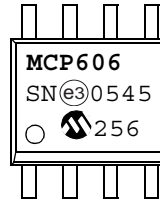
Example:



8-Lead SOIC (150 mil)



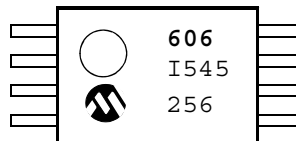
Example:



8-Lead TSSOP



Example:



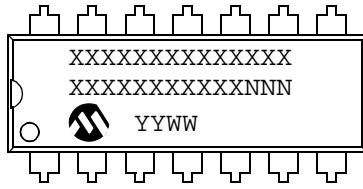
<b>Legend:</b>	XX...X	Customer-specific information
	Y	Year code (last digit of calendar year)
	YY	Year code (last 2 digits of calendar year)
	WW	Week code (week of January 1 is week '01')
	NNN	Alphanumeric traceability code
	(e3)	Pb-free JEDEC designator for Matte Tin (Sn)
	*	This package is Pb-free. The Pb-free JEDEC designator (e3) can be found on the outer packaging for this package.

**Note:** In the event the full Microchip part number cannot be marked on one line, it will be carried over to the next line, thus limiting the number of available characters for customer-specific information.

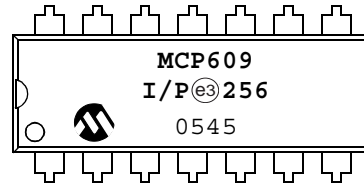


## Package Marking Information (Continued)

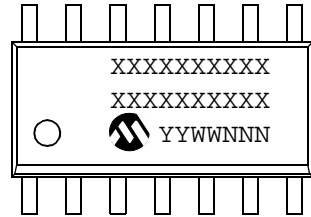
14-Lead PDIP (300 mil) (MCP609)



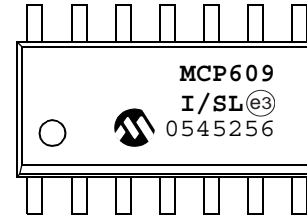
Example:



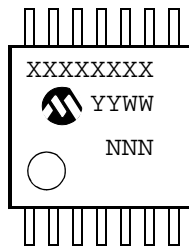
14-Lead SOIC (150 mil) (MCP609)



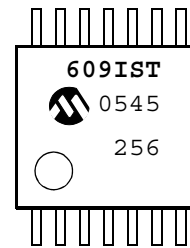
Example:



14-Lead TSSOP (MCP609)

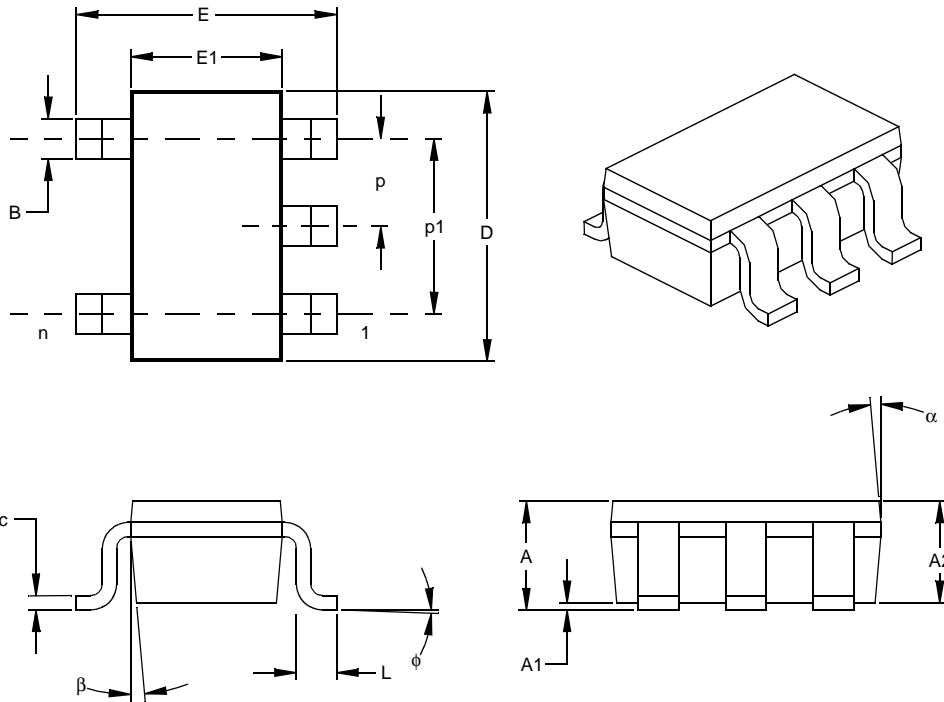


Example:



# MCP606/7/8/9

## 5-Lead Plastic Small Outline Transistor (OT) (SOT23)



Dimension Limits	Units	INCHES*			MILLIMETERS		
		MIN	NOM	MAX	MIN	NOM	MAX
Number of Pins	n		5			5	
Pitch	p		.038			0.95	
Outside lead pitch (basic)	p1		.075			1.90	
Overall Height	A	.035	.046	.057	0.90	1.18	1.45
Molded Package Thickness	A2	.035	.043	.051	0.90	1.10	1.30
Standoff §	A1	.000	.003	.006	0.00	0.08	0.15
Overall Width	E	.102	.110	.118	2.60	2.80	3.00
Molded Package Width	E1	.059	.064	.069	1.50	1.63	1.75
Overall Length	D	.110	.116	.122	2.80	2.95	3.10
Foot Length	L	.014	.018	.022	0.35	0.45	0.55
Foot Angle	φ	0	5	10	0	5	10
Lead Thickness	c	.004	.006	.008	0.09	0.15	0.20
Lead Width	B	.014	.017	.020	0.35	0.43	0.50
Mold Draft Angle Top	α	0	5	10	0	5	10
Mold Draft Angle Bottom	β	0	5	10	0	5	10

\* Controlling Parameter

§ Significant Characteristic

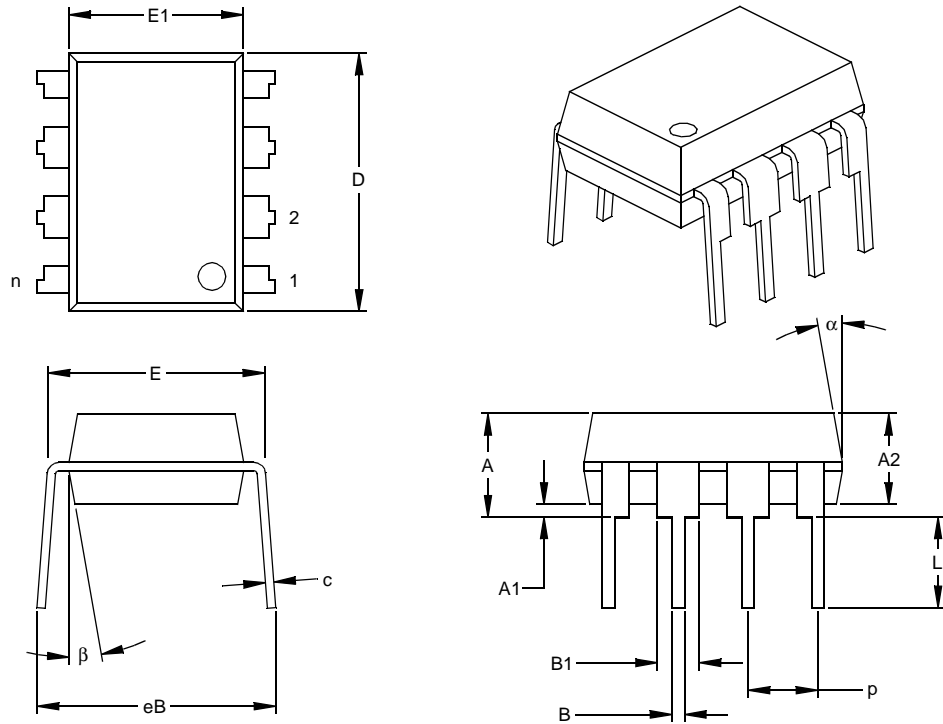
Notes:

Dimensions D and E1 do not include mold flash or protrusions. Mold flash or protrusions shall not exceed .010" (0.254mm) per side.

JEDEC Equivalent: MO-178

Drawing No. C04-091

## 8-Lead Plastic Dual In-line (P) – 300 mil (PDIP)



Dimension Limits	Units	INCHES*			MILLIMETERS		
		MIN	NOM	MAX	MIN	NOM	MAX
Number of Pins	n		8			8	
Pitch	p		.100			2.54	
Top to Seating Plane	A	.140	.155	.170	3.56	3.94	4.32
Molded Package Thickness	A2	.115	.130	.145	2.92	3.30	3.68
Base to Seating Plane	A1	.015			0.38		
Shoulder to Shoulder Width	E	.300	.313	.325	7.62	7.94	8.26
Molded Package Width	E1	.240	.250	.260	6.10	6.35	6.60
Overall Length	D	.360	.373	.385	9.14	9.46	9.78
Tip to Seating Plane	L	.125	.130	.135	3.18	3.30	3.43
Lead Thickness	c	.008	.012	.015	0.20	0.29	0.38
Upper Lead Width	B1	.045	.058	.070	1.14	1.46	1.78
Lower Lead Width	B	.014	.018	.022	0.36	0.46	0.56
Overall Row Spacing	§ eB	.310	.370	.430	7.87	9.40	10.92
Mold Draft Angle Top	α	5	10	15	5	10	15
Mold Draft Angle Bottom	β	5	10	15	5	10	15

\* Controlling Parameter

§ Significant Characteristic

**Notes:**

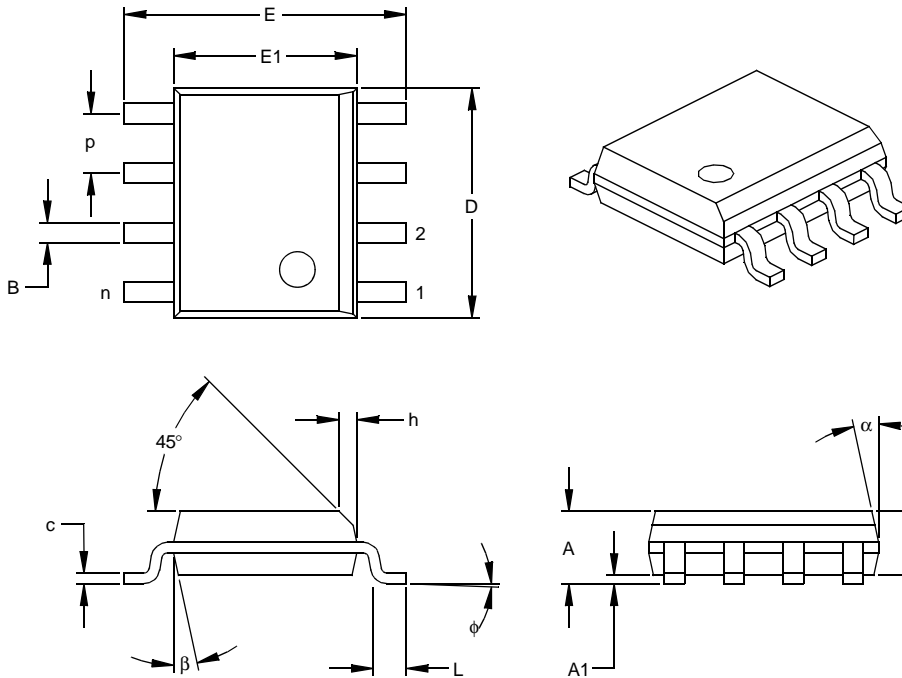
Dimensions D and E1 do not include mold flash or protrusions. Mold flash or protrusions shall not exceed .010" (0.254mm) per side.

JEDEC Equivalent: MS-001

Drawing No. C04-018

# MCP606/7/8/9

## 8-Lead Plastic Small Outline (SN) – Narrow, 150 mil (SOIC)



Dimension Limits	Units	INCHES*			MILLIMETERS		
		MIN	NOM	MAX	MIN	NOM	MAX
Number of Pins	n		8			8	
Pitch	p		.050			1.27	
Overall Height	A	.053	.061	.069	1.35	1.55	1.75
Molded Package Thickness	A2	.052	.056	.061	1.32	1.42	1.55
Standoff §	A1	.004	.007	.010	0.10	0.18	0.25
Overall Width	E	.228	.237	.244	5.79	6.02	6.20
Molded Package Width	E1	.146	.154	.157	3.71	3.91	3.99
Overall Length	D	.189	.193	.197	4.80	4.90	5.00
Chamfer Distance	h	.010	.015	.020	0.25	0.38	0.51
Foot Length	L	.019	.025	.030	0.48	0.62	0.76
Foot Angle	φ	0	4	8	0	4	8
Lead Thickness	c	.008	.009	.010	0.20	0.23	0.25
Lead Width	B	.013	.017	.020	0.33	0.42	0.51
Mold Draft Angle Top	α	0	12	15	0	12	15
Mold Draft Angle Bottom	β	0	12	15	0	12	15

\* Controlling Parameter

§ Significant Characteristic

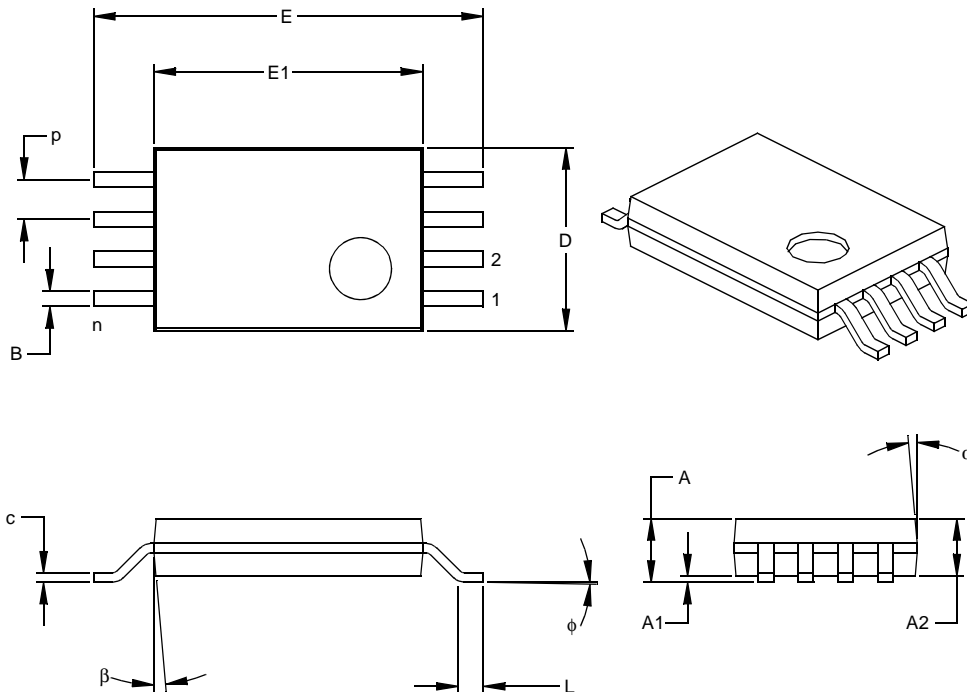
**Notes:**

Dimensions D and E1 do not include mold flash or protrusions. Mold flash or protrusions shall not exceed .010" (0.254mm) per side.

JEDEC Equivalent: MS-012

Drawing No. C04-057

## 8-Lead Plastic Thin Shrink Small Outline (ST) – 4.4 mm (TSSOP)



Units		INCHES			MILLIMETERS*		
Dimension Limits		MIN	NOM	MAX	MIN	NOM	MAX
Number of Pins	n		8			8	
Pitch	p		.026			0.65	
Overall Height	A			.043			1.10
Molded Package Thickness	A2	.033	.035	.037	0.85	0.90	0.95
Standoff §	A1	.002	.004	.006	0.05	0.10	0.15
Overall Width	E	.246	.251	.256	6.25	6.38	6.50
Molded Package Width	E1	.169	.173	.177	4.30	4.40	4.50
Molded Package Length	D	.114	.118	.122	2.90	3.00	3.10
Foot Length	L	.020	.024	.028	0.50	0.60	0.70
Foot Angle	φ	0	4	8	0	4	8
Lead Thickness	c	.004	.006	.008	0.09	0.15	0.20
Lead Width	B	.007	.010	.012	0.19	0.25	0.30
Mold Draft Angle Top	α	0	5	10	0	5	10
Mold Draft Angle Bottom	β	0	5	10	0	5	10

\* Controlling Parameter

§ Significant Characteristic

**Notes:**

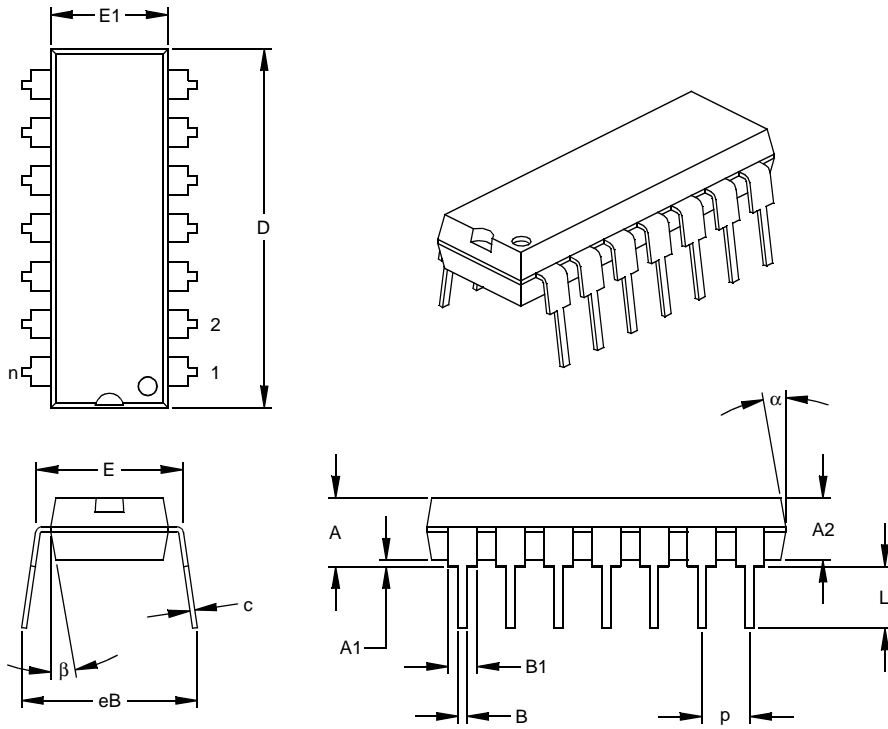
Dimensions D and E1 do not include mold flash or protrusions. Mold flash or protrusions shall not exceed .005" (0.127mm) per side.

JEDEC Equivalent: MO-153

Drawing No. C04-086

# MCP606/7/8/9

## 14-Lead Plastic Dual In-line (P) – 300 mil (PDIP)



Units		INCHES*			MILLIMETERS		
Dimension Limits		MIN	NOM	MAX	MIN	NOM	MAX
Number of Pins	n		14			14	
Pitch	p		.100			2.54	
Top to Seating Plane	A	.140	.155	.170	3.56	3.94	4.32
Molded Package Thickness	A2	.115	.130	.145	2.92	3.30	3.68
Base to Seating Plane	A1	.015			0.38		
Shoulder to Shoulder Width	E	.300	.313	.325	7.62	7.94	8.26
Molded Package Width	E1	.240	.250	.260	6.10	6.35	6.60
Overall Length	D	.740	.750	.760	18.80	19.05	19.30
Tip to Seating Plane	L	.125	.130	.135	3.18	3.30	3.43
Lead Thickness	c	.008	.012	.015	0.20	0.29	0.38
Upper Lead Width	B1	.045	.058	.070	1.14	1.46	1.78
Lower Lead Width	B	.014	.018	.022	0.36	0.46	0.56
Overall Row Spacing	§ eB	.310	.370	.430	7.87	9.40	10.92
Mold Draft Angle Top	α	5	10	15	5	10	15
Mold Draft Angle Bottom	β	5	10	15	5	10	15

\* Controlling Parameter

§ Significant Characteristic

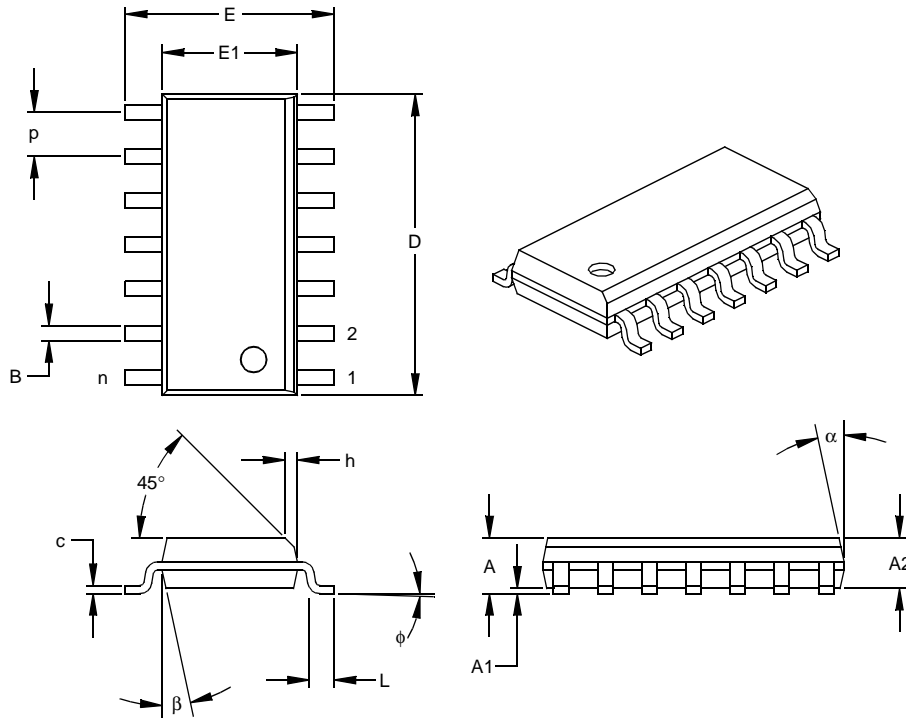
Notes:

Dimensions D and E1 do not include mold flash or protrusions. Mold flash or protrusions shall not exceed .010" (0.254mm) per side.

JEDEC Equivalent: MS-001

Drawing No. C04-005

## 14-Lead Plastic Small Outline (SL) – Narrow, 150 mil (SOIC)



Dimension Limits	Units	INCHES*			MILLIMETERS		
		MIN	NOM	MAX	MIN	NOM	MAX
Number of Pins	n		14			14	
Pitch	p		.050			1.27	
Overall Height	A	.053	.061	.069	1.35	1.55	1.75
Molded Package Thickness	A2	.052	.056	.061	1.32	1.42	1.55
Standoff §	A1	.004	.007	.010	0.10	0.18	0.25
Overall Width	E	.228	.236	.244	5.79	5.99	6.20
Molded Package Width	E1	.150	.154	.157	3.81	3.90	3.99
Overall Length	D	.337	.342	.347	8.56	8.69	8.81
Chamfer Distance	h	.010	.015	.020	0.25	0.38	0.51
Foot Length	L	.016	.033	.050	0.41	0.84	1.27
Foot Angle	φ	0	4	8	0	4	8
Lead Thickness	c	.008	.009	.010	0.20	0.23	0.25
Lead Width	B	.014	.017	.020	0.36	0.42	0.51
Mold Draft Angle Top	α	0	12	15	0	12	15
Mold Draft Angle Bottom	β	0	12	15	0	12	15

\* Controlling Parameter

§ Significant Characteristic

Notes:

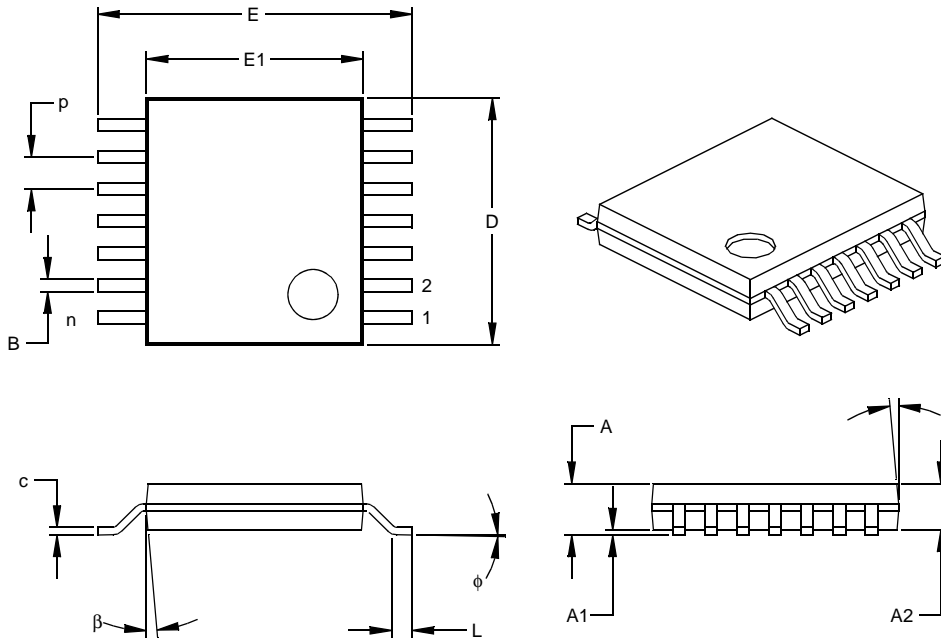
Dimensions D and E1 do not include mold flash or protrusions. Mold flash or protrusions shall not exceed .010" (0.254mm) per side.

JEDEC Equivalent: MS-012

Drawing No. C04-065

# MCP606/7/8/9

## 14-Lead Plastic Thin Shrink Small Outline (ST) – 4.4 mm (TSSOP)



Dimension Limits	Units	INCHES			MILLIMETERS*		
		MIN	NOM	MAX	MIN	NOM	MAX
Number of Pins	n		14			14	
Pitch	p		.026			0.65	
Overall Height	A			.043			1.10
Molded Package Thickness	A2	.033	.035	.037	0.85	0.90	0.95
Standoff §	A1	.002	.004	.006	0.05	0.10	0.15
Overall Width	E	.246	.251	.256	6.25	6.38	6.50
Molded Package Width	E1	.169	.173	.177	4.30	4.40	4.50
Molded Package Length	D	.193	.197	.201	4.90	5.00	5.10
Foot Length	L	.020	.024	.028	0.50	0.60	0.70
Foot Angle	φ	0	4	8	0	4	8
Lead Thickness	c	.004	.006	.008	0.09	0.15	0.20
Lead Width	B1	.007	.010	.012	0.19	0.25	0.30
Mold Draft Angle Top	α	0	5	10	0	5	10
Mold Draft Angle Bottom	β	0	5	10	0	5	10

\* Controlling Parameter  
 § Significant Characteristic

Notes:

Dimensions D and E1 do not include mold flash or protrusions. Mold flash or protrusions shall not exceed .005" (0.127mm) per side.

JEDEC Equivalent: MO-153

Drawing No. C04-087



## APPENDIX A: REVISION HISTORY

### Revision D (February 2005)

The following is the list of modifications:

1. Added **Section 3.0 “Pin Descriptions”**.
2. Updated **Section 4.0 “Applications Information”**.
3. Added **Section 4.3 “Capacitive Loads”**
4. Updated **Section 5.0 “Design Tools”** to include FilterLab<sup>®</sup> and to point to the latest SPICE macro model.
5. Corrected and updated **Section 6.0 “Packaging Information”**.
6. Added **Section Appendix A: “Revision History”**.

### Revision C (January 2001)

### Revision B (May 2000)

### Revision A (January 2000)

- Original Release of this Document.

# MCP606/7/8/9

---

NOTES:

## PRODUCT IDENTIFICATION SYSTEM

To order or obtain information, e.g., on pricing or delivery, refer to the factory or the listed sales office.

<u>PART NO.</u>	<u>X</u>	<u>/XX</u>	
Device	Temperature Range	Package	
Device			MCP606 = Single Op Amp MCP606T = Single Op Amp Tape and Reel (SOIC, TSSOP) MCP607 = Dual Op Amp MCP607T = Dual Op Amp Tape and Reel (SOIC, TSSOP) MCP608 = Single Op Amp with <u>CS</u> MCP608T = Single Op Amp with <u>CS</u> Tape and Reel (SOIC, TSSOP) MCP609 = Quad Op Amp MCP609T = Quad Op Amp Tape and Reel (SOIC, TSSOP)
Temperature Range	I	=	-40°C to +85°C
Package			OT = Plastic SOT-23, 5-lead P = Plastic DIP (300 mil Body), 8-lead & 14-lead SN = Plastic SOIC (150 mil Body), 8-lead SL = Plastic SOIC (150 mil Body), 14-lead ST = Plastic TSSOP, 8-lead & 14-lead

**Examples:**

- a) MCP606-I/P: Industrial Temperature, 8LD PDIP package.
- b) MCP606-I/SN: Industrial Temperature, 8LD SOIC package.
- c) MCP606T-I/SN: Tape and Reel, Industrial Temperature, 8LD SOIC package.
- d) MCP606-I/ST: Industrial Temperature, 8LD TSSOP package.
- e) MCP606-I/OT: Industrial Temperature, 5LD SOT-23 package.
- f) MCP606T-I/OT: Tape and Reel, Industrial Temperature, 5LD SOT-23 package.
  
- a) MCP607-I/P: Industrial Temperature, 8LD PDIP package.
- b) MCP607T-I/P: Industrial Temperature, 8LD PDIP package.
  
- a) MCP608-I/SN: Industrial Temperature, 8LD SOIC package.
- b) MCP608T-I/SN: Tape and Reel, Industrial Temperature, 8LD SOIC package.
  
- a) MCP609-I/P: Industrial Temperature, 14LD PDIP package.
- b) MCP609T-I/P: Industrial Temperature, 14LD PDIP package.

# MCP606/7/8/9

---

NOTES:

---

---

**Note the following details of the code protection feature on Microchip devices:**

- Microchip products meet the specification contained in their particular Microchip Data Sheet.
- Microchip believes that its family of products is one of the most secure families of its kind on the market today, when used in the intended manner and under normal conditions.
- There are dishonest and possibly illegal methods used to breach the code protection feature. All of these methods, to our knowledge, require using the Microchip products in a manner outside the operating specifications contained in Microchip's Data Sheets. Most likely, the person doing so is engaged in theft of intellectual property.
- Microchip is willing to work with the customer who is concerned about the integrity of their code.
- Neither Microchip nor any other semiconductor manufacturer can guarantee the security of their code. Code protection does not mean that we are guaranteeing the product as "unbreakable."

Code protection is constantly evolving. We at Microchip are committed to continuously improving the code protection features of our products. Attempts to break Microchip's code protection feature may be a violation of the Digital Millennium Copyright Act. If such acts allow unauthorized access to your software or other copyrighted work, you may have a right to sue for relief under that Act.

---

Information contained in this publication regarding device applications and the like is provided only for your convenience and may be superseded by updates. It is your responsibility to ensure that your application meets with your specifications. MICROCHIP MAKES NO REPRESENTATIONS OR WARRANTIES OF ANY KIND WHETHER EXPRESS OR IMPLIED, WRITTEN OR ORAL, STATUTORY OR OTHERWISE, RELATED TO THE INFORMATION, INCLUDING BUT NOT LIMITED TO ITS CONDITION, QUALITY, PERFORMANCE, MERCHANTABILITY OR FITNESS FOR PURPOSE. Microchip disclaims all liability arising from this information and its use. Use of Microchip's products as critical components in life support systems is not authorized except with express written approval by Microchip. No licenses are conveyed, implicitly or otherwise, under any Microchip intellectual property rights.

**Trademarks**

The Microchip name and logo, the Microchip logo, Accuron, dsPIC, KEELOQ, microID, MPLAB, PIC, PICmicro, PICSTART, PRO MATE, PowerSmart, rPIC, and SmartShunt are registered trademarks of Microchip Technology Incorporated in the U.S.A. and other countries.


AmpLab, FilterLab, Migratable Memory, MXDEV, MXLAB, PICMASTER, SEEVAL, SmartSensor and The Embedded Control Solutions Company are registered trademarks of Microchip Technology Incorporated in the U.S.A.

Analog-for-the-Digital Age, Application Maestro, dsPICDEM, dsPICDEM.net, dsPICworks, ECAN, ECONOMONITOR, FanSense, FlexROM, fuzzyLAB, In-Circuit Serial Programming, ICSP, ICEPIC, MPASM, MPLIB, MPLINK, MPSIM, PICKit, PICDEM, PICDEM.net, PICLAB, PICtail, PowerCal, PowerInfo, PowerMate, PowerTool, rLAB, rPICDEM, Select Mode, Smart Serial, SmartTel, Total Endurance and WiperLock are trademarks of Microchip Technology Incorporated in the U.S.A. and other countries.

SQTP is a service mark of Microchip Technology Incorporated in the U.S.A.

All other trademarks mentioned herein are property of their respective companies.

© 2005, Microchip Technology Incorporated, Printed in the U.S.A., All Rights Reserved.

 Printed on recycled paper.

**QUALITY MANAGEMENT SYSTEM**  
**CERTIFIED BY DNV**  
**== ISO/TS 16949:2002 ==**

*Microchip received ISO/TS-16949:2002 quality system certification for its worldwide headquarters, design and wafer fabrication facilities in Chandler and Tempe, Arizona and Mountain View, California in October 2003. The Company's quality system processes and procedures are for its PICmicro® 8-bit MCUs, KEELOQ® code hopping devices, Serial EEPROMs, microperipherals, nonvolatile memory and analog products. In addition, Microchip's quality system for the design and manufacture of development systems is ISO 9001:2000 certified.*



---

---

## WORLDWIDE SALES AND SERVICE

---

---

### AMERICAS

**Corporate Office**  
2355 West Chandler Blvd.  
Chandler, AZ 85224-6199  
Tel: 480-792-7200  
Fax: 480-792-7277  
Technical Support:  
<http://support.microchip.com>  
Web Address:  
[www.microchip.com](http://www.microchip.com)

**Atlanta**  
Alpharetta, GA  
Tel: 770-640-0034  
Fax: 770-640-0307

**Boston**  
Westford, MA  
Tel: 978-692-3848  
Fax: 978-692-3821

**Chicago**  
Itasca, IL  
Tel: 630-285-0071  
Fax: 630-285-0075

**Dallas**  
Addison, TX  
Tel: 972-818-7423  
Fax: 972-818-2924

**Detroit**  
Farmington Hills, MI  
Tel: 248-538-2250  
Fax: 248-538-2260

**Kokomo**  
Kokomo, IN  
Tel: 765-864-8360  
Fax: 765-864-8387

**Los Angeles**  
Mission Viejo, CA  
Tel: 949-462-9523  
Fax: 949-462-9608

**San Jose**  
Mountain View, CA  
Tel: 650-215-1444  
Fax: 650-961-0286

**Toronto**  
Mississauga, Ontario,  
Canada  
Tel: 905-673-0699  
Fax: 905-673-6509

### ASIA/PACIFIC

**Australia - Sydney**  
Tel: 61-2-9868-6733  
Fax: 61-2-9868-6755

**China - Beijing**  
Tel: 86-10-8528-2100  
Fax: 86-10-8528-2104

**China - Chengdu**  
Tel: 86-28-8676-6200  
Fax: 86-28-8676-6599

**China - Fuzhou**  
Tel: 86-591-8750-3506  
Fax: 86-591-8750-3521

**China - Hong Kong SAR**  
Tel: 852-2401-1200  
Fax: 852-2401-3431

**China - Shanghai**  
Tel: 86-21-5407-5533  
Fax: 86-21-5407-5066

**China - Shenyang**  
Tel: 86-24-2334-2829  
Fax: 86-24-2334-2393

**China - Shenzhen**  
Tel: 86-755-8203-2660  
Fax: 86-755-8203-1760

**China - Shunde**  
Tel: 86-757-2839-5507  
Fax: 86-757-2839-5571

**China - Qingdao**  
Tel: 86-532-502-7355  
Fax: 86-532-502-7205

### ASIA/PACIFIC

**India - Bangalore**  
Tel: 91-80-2229-0061  
Fax: 91-80-2229-0062

**India - New Delhi**  
Tel: 91-11-5160-8631  
Fax: 91-11-5160-8632

**Japan - Kanagawa**  
Tel: 81-45-471- 6166  
Fax: 81-45-471-6122

**Korea - Seoul**  
Tel: 82-2-554-7200  
Fax: 82-2-558-5932 or  
82-2-558-5934

**Singapore**  
Tel: 65-6334-8870  
Fax: 65-6334-8850

**Taiwan - Kaohsiung**  
Tel: 886-7-536-4818  
Fax: 886-7-536-4803

**Taiwan - Taipei**  
Tel: 886-2-2500-6610  
Fax: 886-2-2508-0102

**Taiwan - Hsinchu**  
Tel: 886-3-572-9526  
Fax: 886-3-572-6459

### EUROPE

**Austria - Weis**  
Tel: 43-7242-2244-399  
Fax: 43-7242-2244-393

**Denmark - Ballerup**  
Tel: 45-4450-2828  
Fax: 45-4485-2829

**France - Massy**  
Tel: 33-1-69-53-63-20  
Fax: 33-1-69-30-90-79

**Germany - Ismaning**  
Tel: 49-89-627-144-0  
Fax: 49-89-627-144-44

**Italy - Milan**  
Tel: 39-0331-742611  
Fax: 39-0331-466781

**Netherlands - Drunen**  
Tel: 31-416-690399  
Fax: 31-416-690340

**England - Berkshire**  
Tel: 44-118-921-5869  
Fax: 44-118-921-5820